

SPECIAL PAPERS IN PALAEOLOGY

Number 18

OSTRACODERM FAUNAS OF  
THE DELORME AND ASSOCIATED  
SILURO-DEVONIAN FORMATIONS  
NORTH WEST TERRITORIES  
CANADA

BY

D. L. DINELEY

*and*

E. J. LOEFFLER

PUBLISHED BY  
THE PALAEOLOGICAL ASSOCIATION  
LONDON

*Price* £20·00

SPECIAL PAPERS IN PALAEOLOGY NO. 18

---

OSTRACODERM FAUNAS OF THE  
DELORME AND ASSOCIATED  
SILURO-DEVONIAN FORMATIONS  
NORTH WEST TERRITORIES  
CANADA

BY  
D. L. DINELEY  
*and*  
E. J. LOEFFLER

With 33 plates, 78 text-figures, and 1 table

THE PALAEOLOGICAL ASSOCIATION  
LONDON  
NOVEMBER 1976

© *The Palaeontological Association, 1976*

DINELEY, D. L. and LOEFFLER, E. J. 1976. Ostracoderm Faunas of the Delorme and associated Siluro-Devonian Formations, North West Territories, Canada. *Spec. Pap. Palaeontology*, 1976. iv+214 pp., 33 plates, 78 text-figs., 1 table.

*Printed in Great Britain*

# CONTENTS

Abstract	v
Introduction	1
Systematic Palaeontology	14
Order Heterostraci	17
Family Traquairaspididae	17
General Comments on the Traquairaspididae	42
Family Corvaspididae	46
General Comments on the Corvaspididae	49
Family Cyathaspididae	52
Subfamily Tolypelepidinae	53
Subfamily Cyathaspidinae	58
Subfamily Poraspidinae	75
Subfamily Irregulareaspidinae	84
General Comments on the Cyathaspididae	102
Family Pteraspididae	112
General Comments on the Pteraspididae	127
Incertae Familiae	136
Order Thelodontida	152
General Comments on the Thelodontida	156
Order Osteostraci	158
General Comments on the Osteostraci	173
Incertae Sedis	175
Conclusions	190
Ostracoderm Biostratigraphy	190
Ostracoderms and Boundaries	199
Distribution of the Ostracoderms	201
The Habitat of the Ostracoderms	205
Acknowledgements	208
References	208

**ABSTRACT.** Vertebrates from several horizons within the Delorme Formation and associated Siluro-Devonian strata in Canada's District of Mackenzie (N.W.T.) include members of the ostracoderm families Traquairaspididae, Corvaspididae, Cyathaspididae, Pteraspididae, and Cephalaspididae, and of the order Thelodontida.

The Traquairaspididae is represented by eight new species displaying unusual variation in ventral ornamentation and including forms in which the dorsal shield comprises a single plate: all are referred to ?*Traquairaspis*. The biostratigraphic range of the family appears to be Middle Silurian to Dittonian.

Eighteen species of the Cyathaspididae include single species of the new genera *Asketaspis* and *Nahanniaspis* and one new species of *Vernonaspis*, *Tolypelepis*, and *Pionaspis*. The rest of the material is accommodated by use of open nomenclature. Articulated specimens of *Nahanniaspis mackenziei* gen. et sp. nov. and *Dinaspidella* sp. indet. are used to elucidate relationships with the family. *Dikenaspis* is relegated to the Cyathaspidinae. The Irregularaspidinae and Cyathaspidinae are thought to have evolved anastomosing lateral line systems independently. Superficial concentric zones on the shields of several species are interpreted as growth marks and show different patterns of growth in three subfamilies; they confirm the epitega as independent units of growth. It is also shown that the superficial layer was capable of limited regeneration.

The family Pteraspididae is revised, being represented here by at least three new species which are included in the new genus *Canadapteraspis*, together with an established species previously referred to *Althaspis*. This family is thought to be more closely related to the Traquairaspididae than to the Cyathaspididae.

*Aserotaspis canadensis* gen. et sp. nov. and *Natlaspis planicosta* gen. et sp. nov. are distinctive, but their affinities remain obscure. The former may be close to *Tesseraspis*, but the latter may be akin to some of the traquairaspidids.

Of the several species of Osteostraci described, only one is new; the rest are accommodated by open nomenclature. The new species of *Cephalaspis* is a bizarre form with a barbed dorsal spine.

Articulated thelodonts are referred to a new species of *Sigurdia* Heintz. Pending detailed histological investigation, the many isolated denticles are referred to Types 1-5.

*Lepidaspis serrata* gen. et sp. nov., a form with armour of scale-like units, is tentatively referred to the Agnatha.

These faunas are of use in a revision of the age of Silurian and Devonian ostracoderm occurrences in Europe and North America and in a discussion of ostracoderm provinciality. 'North American' and 'European' areas were characterized in the Silurian by more common Heterostraci and Osteostraci, respectively. Continental collision and the spread of Old Red Sandstone facies facilitated the fusion of the two provinces.

## INTRODUCTION

THE armoured, jawless, fish-like vertebrates known as ostracoderms are an important element of Late Silurian and Early Devonian faunas throughout Europe, Spitsbergen, Western U.S.S.R., U.S.A., and Eastern Canada. Since they were used by White (1950a) to zone the Lower Old Red Sandstone of the Anglo-Welsh borderlands, ostracoderms have proved to be of stratigraphic value in the Late Silurian and Early Devonian of widely separated areas. More recently, it has also been suggested that ostracoderms might be used to mark the revised Siluro-Devonian boundary in the non-marine facies.

The abundant ostracoderm material described here was amassed between 1963 and 1967 by a succession of collectors involved in geological exploration of the southern Mackenzie Mountains, in the south-west of the District of Mackenzie, North West Territories. The area (text-fig. 1) comprises four Geological Survey of Canada map areas: Nahanni in the south-west, Mount Sekwi in the north-west, Wrigley Lake in the north-east, and Glacier Lake in the south-east. Material from Survey localities in the Wrigley Lake and Glacier Lake map areas was collected by B. S. Norford and H. Gabrielse in 1963 and 1965, during the course of the Geological Survey of Canada's 'Operation Nahanni'. In 1967 D. L. Dineley worked some of these localities and also made collections at others within the Mount Sekwi map area, as part of the Geological Survey of Canada's 'Operation Selwyn'. During the summer of 1964, the Chevron Standard Company's field parties led by A. Lenz retrieved ostracoderms from sections within the Mount Sekwi, Wrigley Lake, and Glacier Lake map areas.

All of this material came into the hands of D. L. Dineley by courtesy of the Geological Survey of Canada and Dr. Lenz. A complete description of the ostracoderm material has been attempted; acanthodians from GSC locality 69014 (Glacier Lake map area) have been studied by G. M. Bernacsek of the University of Bristol.

Much significance has attached to these discoveries and to others in the Arctic islands, because they were thought to provide a ready means of correlation with the Late Silurian and Early Devonian of Europe. It has become apparent, however, that some of these faunas are rather older than those in Europe; graptolites associated with ostracoderms in the Cape Phillips Formation of Cornwallis Island (Thorsteinsson 1967) indicate a Late Llandoveryan or Early Wenlockian age for one assemblage. Some of the more significant collections remain undescribed. Independent invertebrate datings suggested that the same groups of ostracoderms appeared earlier in Canada than in Europe; consequently, correlation on the basis of ostracoderms has come to be regarded as unreliable. As long ago as 1958, it was recognized that the position of the Siluro-Devonian boundary was subject to differing usage throughout the world and even within Europe. This boundary, recently revised to coincide with the base of the graptolite zone of *Monograptus uniformis uniformis*, results in the equating of part of the Downtonian (Old Red facies) Stage with the post-Ludlovian, Pridolian Stage of the Late Silurian.

The present study of ostracoderms from the Delorme Formation and associated Siluro-Devonian strata of the District of Mackenzie, considers their relevance to outstanding questions about the morphology, growth, relationships, and distribution of the ostracoderms. During the course of the work it became apparent that, prior to comparing Canadian and European ostracoderm faunas, it would be necessary to review accepted correlations of European vertebrate-bearing strata in the light of recent evidence from fossil invertebrates and from the repositioning of the Siluro-Devonian boundary. Once it became evident that certain groups of ostracoderms, notably the Traquairaspididae and Corvaspididae, might have appeared earlier in Canada than in Europe, it became necessary to revise those Canadian correlations which had been based on the European ranges of these ostracoderms. These revisions produced a new and different picture of the temporal distribution of the ostracoderms (p. 190).

#### Geological setting

The Mackenzie Mountains, which form part of the Cordilleran Orogenic Belt, are characterized by thick sequences of Palaeozoic carbonate and clastic rocks which were thrown into simple folds, with intervening zones of complex folds and faults, during the Columbian and Laramide orogenies. In the area shown in text-fig. 1, well-bedded carbonates and clastics range in age from Helikian (Proterozoic) to Late Devonian; across a narrow, north-westerly trending zone the Late Ordovician to Middle Devonian strata change facies abruptly from carbonates in the north-east to fine-grained clastics in the south-west.

Mapping of the area was begun by the Geological Survey of Canada in 1963, in conjunction with 'Operation Nahanni', and completed in 1967 during 'Operation Selwyn'. A full report on the geology of the Glacier Lake and Wrigley Lake map areas (Gabrielse *et al.* 1973) gives the geographical and stratigraphical position of the G.S.C. ostracoderm localities and the ages of associated invertebrate fossils. Although maps and preliminary reports of the Nahanni (Green *et al.* 1967) and Mount Sekwi (Blusson 1971) map areas are available, they give no details of ostracoderm localities or sections. The Chevron Standard Co. kindly provided details of each of their localities, together with identifications and ages of associated invertebrate faunas. In most instances, however, it was not possible to identify the formation yielding ostracoderms.

Of those ostracoderm horizons which have been assigned to formations, all but one are within the Delorme Formation or the transitional facies between it and Road River Formation; the exception, Chevron Standard locality YA20, was ascribed by Chevron Standard Co. geologists to the Whittaker Formation.

Unless otherwise acknowledged, information concerning the Late Silurian and Early Devonian stratigraphy of the area is summarized from the appropriate Geological Survey of Canada map reports (see above).

**The Whittaker Formation:** The name 'Whittaker Formation' was applied by Douglas and Norris (1961) to 1220 m of carbonate strata in the Whittaker Range of the south-eastern Mackenzie Mountains. In the Glacier Lake and Wrigley Lake map areas, the Whittaker Formation comprises well-bedded, commonly cherty, dark-grey weathering dolomite and light-grey weathering dolomite and limestone. In the

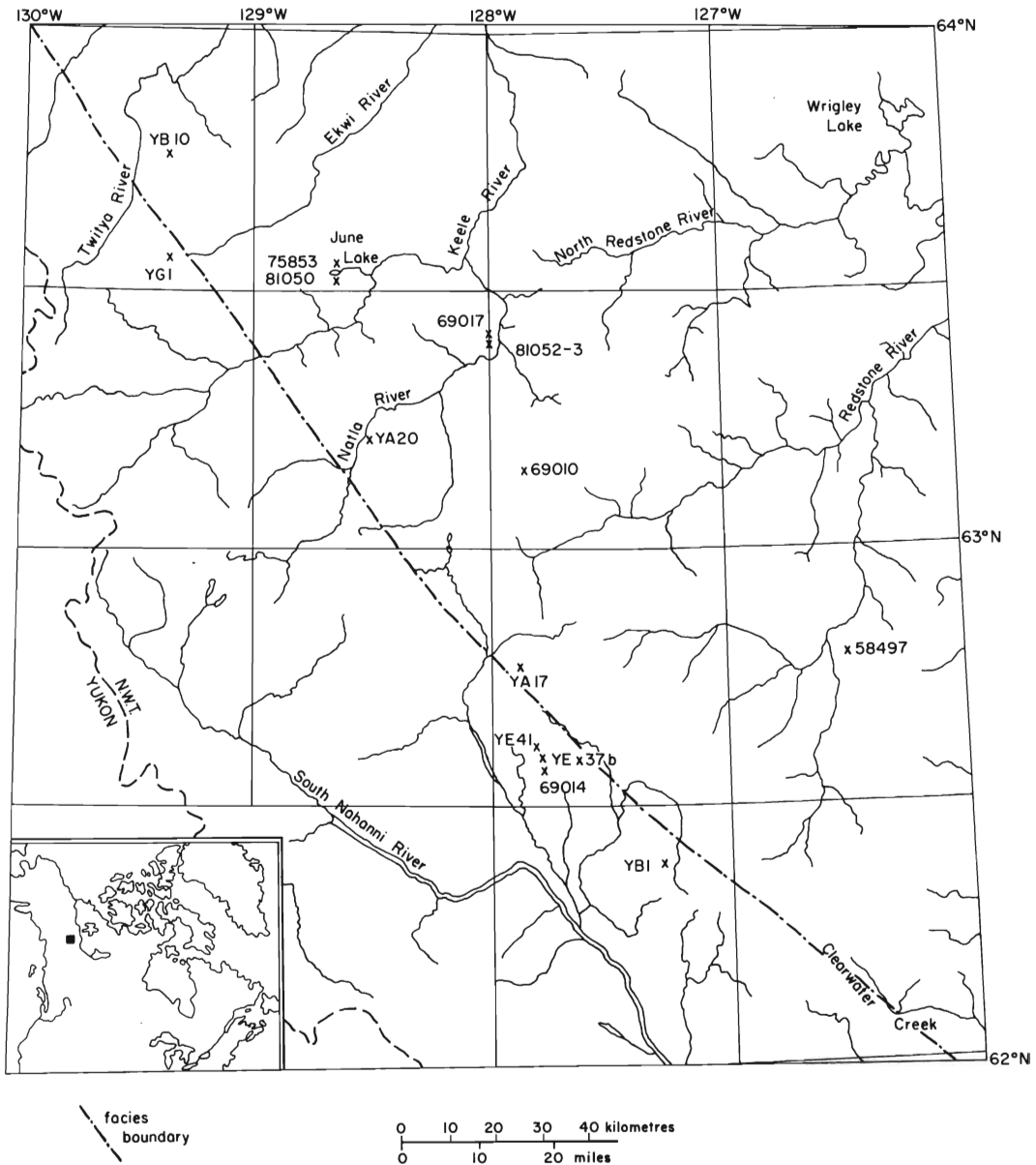

TEXT-FIG. 1. Western District of Mackenzie, showing localities from which the ostracoderm collections were made. G.S.C. localities 81051 and 81057 are not shown because their exact geographical positions are not known. For details of localities see pp. 4-14.



Mount Sekwi map area, it is typically developed only in the east and north-east; in the Nahanni map area, it is present only in the north-east. Invertebrate faunas, which are relatively rare in the upper part, suggest that the Whittaker Formation ranges in age from Late Ordovician to Silurian. Douglas *et al.* (1968) report that the upper part has yielded Ludlovian graptolites.

**The Delorme Formation:** The Delorme Formation was established by Douglas and Norris (1961) for the limestones, dolomites, and shales overlying the Whittaker Formation and underlying the Camsell Formation in the Camsell Bend and Root River map areas; the type locality, on Delorme Range, includes 990 m of strata. In Wrigley Lake and Glacier Lake map areas, the Delorme Formation comprises generally recessive, buff, grey, cream and cinnamon-weathering, platy, mottled dolomites and limestones. The rocks are commonly fine-grained, thinly bedded, and locally laminated. In the Mount Sekwi map area, the Delorme Formation is typically developed only in the east and north; in the Nahanni map area it crops out only in the north-east. The Delorme Formation is conformable on the Whittaker Formation throughout the region. Fossils are rare in the Delorme Formation of the Glacier Lake and Wrigley Lake map areas, but include ostracoderms and local concentrations of brachiopods; within the Mount Sekwi map area, fossils are more common, particularly in the shaly and calcareous beds, which contain ostracods, graptolites, brachiopods, and ostracoderms. Gabrielse *et al.* (1973) suggest a Late Silurian to Early Devonian age for the base of the Delorme Formation; Lenz (*in* Berry and Boucot 1970) considers that the base of the Delorme Formation is diachronous, ranging in age from the zone of *Monograptus nilssoni* to the Lochkovian.

Two tectonic elements, the Mackenzie Arch and the Selwyn Basin, had an important effect on sedimentation within the region during Late Silurian and Early Devonian times, being responsible for the facies change already mentioned. Near an approximately north-westerly trending line, passing through Clearwater Creek, Grizzly Bear Lake, and the north-west corner of Mount Sekwi map area (text-fig. 1), which marks the western limit of the Mackenzie Arch, Late Silurian and Early Devonian strata undergo an abrupt facies change. The Whittaker and younger formations change from carbonates in the north-east to shales in the south-west. Gabrielse *et al.* (1973) have proposed that these shales, together with similar rocks throughout the Selwyn Basin, be referred to the Road River Formation. Although the facies change is abrupt, transitional beds are present; the vertebrates from GSC locality 69014 are from beds of the transitional facies between the Road River Formation and the Delorme, Camsell, and Sombre Formations (Gabrielse *et al.* 1973).

*Localities.* The localities listed below are referred to by the code numbers and letters allotted by the Geological Survey of Canada (prefix GSC) and the Chevron Standard Co. (prefix CS). Further details of the sections at GSC localities 58497, 69010, 69014, and 69017 are given in Gabrielse *et al.* (1973).

Locality code	Latitude	Longitude	Position of locality
GSC 58497	62° 46' N.	126° 30' W.	Northernmost Thundercloud Range, 55 m above the base of the Delorme Formation.

Stratigraphically 238 m above a horizon containing invertebrates which were dated as Silurian (B. S. Norford in Gabrielse *et al.* 1973, p. 63).

Ostracoderm fauna:

? <i>Traquairaspis</i> cf. ? <i>T. pustulata</i> sp. nov.	Poraspidinae indet., Type 1
<i>Archegonaspis</i> sp. indet., Type 1	Cyathaspididae indet., Type 2
Cyathaspidinae indet., Type 3	Heterostraci indet., Type 3
<i>Homalaspidella</i> sp. indet., Type 2	Heterostraci indet., Type 5

The stratigraphic position and invertebrate fauna indicate a Late Silurian or Early Devonian age for this horizon; although the ostracoderm assemblage suggests a Silurian age, *Traquairaspis*, *Archegonaspis*, and *Homalaspidella* have also been reported from the Devonian.

Lithology and invertebrate fauna: Light and dark mottled dolomite, with lingulid brachiopods; slightly higher and lower beds in the same section (Section 37, Gabrielse *et al.* 1973) display mud cracks.

Preservation of ostracoderms: Disarticulated and fragmented plates with random orientation, but no sign of abrasion.

Interpretation of environment: Shallow water, probably of low salinity; low-energy levels, but perhaps periodic flooding or tidal movement of water.

GSC 69010    63° 10' N.            127° 53' W.            South-west of the Natla fault, 80 m above the base of the Delorme Formation.

(Section 19, Gabrielse *et al.* 1973), 378 m stratigraphically above a horizon which was dated as Ordovician (Gabrielse *et al.* 1973, p. 60). Its position within the Delorme Formation suggests a Late Silurian or Early Devonian age.

Ostracoderm fauna: Cyathaspidinae indet., Type 4.

Neither the ostracoderms nor the stratigraphic position indicate the exact age of this horizon.

Lithology: Shaly, grey-green dolomite; no invertebrate fossils known.

Preservation of ostracoderms: Slightly abraded, disarticulated plates and scales.

Interpretation of environment: Quiet deposition, no signs of local biota: fossils introduced by rare influxes from elsewhere.

GSC 69014    62° 33' N.            127° 45' W.            South-west limb of the Grizzly Bear anticline, 260 m above the top of the Whittaker Formation, in transitional facies between the Delorme and Road River Formations.

(Section 43, Gabrielse *et al.* 1973), 39 m stratigraphically above GSC locality 69059 which yields *Coenites* sp., *Schizophoria* sp., *Carinatina* sp., and *Spinatrypa*, was dated as Early Devonian (A. W. Norris in Gabrielse *et al.* 1973, p. 74).

## Ostracoderm fauna:

<i>Pionaspis amplissima</i> sp. nov.	Cephalaspidinae indet.
Cyathaspidinae indet., Type 1	Cephalaspididae indet., Type 1
<i>Poraspis</i> cf. <i>P. polaris</i>	Cephalaspididae indet., Type 2
<i>Poraspis</i> sp. indet.	Cephalaspididae indet. (unspecified)
<i>Dinaspidella</i> sp. indet.	Osteostraci indet.
<i>Nahanniaspis mackenziei</i> gen. et sp. nov.	<i>Lepidaspis serrata</i> gen. et sp. nov.
<i>Canadapterspis alocostomata</i> gen. et sp. nov.	cf. <i>Lepidaspis serrata</i> , Type 1
Heterostraci indet., Type 6	cf. <i>Lepidaspis serrata</i> , Type 2
<i>Cephalaspis</i> sp. indet.	<i>Aserotaspis canadensis</i> gen. et sp. nov.
? <i>Cephalaspis gabrielsei</i> sp. nov.	<i>Sigurdia heintzae</i> sp. nov.

The ostracoderm fauna has close affinities with that of the upper part of the Fraenkelryggen Formation and the lower part of the Ben Nevis Formation of the Red Bay Group of Spitsbergen, which has been correlated with the lower part of the Dittonian (*sensu* White 1950a) of Britain (Ørvig 1969a).

*Sigurdia* has previously been recorded only from the Ben Nevis Formation (Heintz 1970); *Dinaspidella* and *Poraspis polaris* were regarded by Kiaer (1932) and Kiaer and Heintz (1935) as particularly characteristic of the upper part of the Fraenkelryggen Formation, above and including the *primaeva* horizon. The pteraspiddid, *Canadapterspis* appears to be close to *Protopteraspis*, which occurs in the upper part of the Fraenkelryggen Formation and the lower part of the Ben Nevis Formation. The latter genus is also characteristic of the lowest part of the Dittonian of the Anglo-Welsh borders. *Cephalaspis* is recorded only from Devonian strata and is common throughout the Fraenkelryggen and Ben Nevis Formations. The age of the ostracoderm fauna at GSC locality 69014 is thus considered to be early Dittonian.

Lithology and invertebrate fauna: Laminated, shaly, dark, and carbonaceous pyritiferous dolomite with abundant ostracods, rare eurypterids, articulate and inarticulate brachiopods.

Preservation of ostracoderms: Thelodont, osteostracan, and heterostracan material is abundant and articulated; acanthodians are also present.

Interpretation of environment: The invertebrate fauna of the ostracoderm horizon is suggestive of hyposaline conditions; marine invertebrates are present but rare (Dineley 1968b) and ostracods, although present in large numbers, appear to include a small number of different forms.

The matrix has yielded poorly preserved spores. Light and dark laminations may reflect original variation in oxygen levels within the environment, caused perhaps by periodic algal blooms; the presence of pyrite suggests that conditions were occasionally anaerobic. Lack of bioturbation and the absence of benthos suggests that the bottom was commonly foul.

Dineley (1968b) concluded that the lithology and invertebrate fauna were probably the product of a lagoonal environment with quiet sedimentation. Rapid facies changes occur over short distances in this area (D. Perry, pers. comm.) and possibly reflect local emergence and the development of shoals and lagoons.

The composition of the vertebrate fauna is also indicative of hyposaline conditions. Early Devonian Osteostraci (Denison 1956) and Thelodontida (Halstead and

Turner 1973) were almost entirely restricted to fresh water elsewhere; at the same time, the Cyathaspididae, Pteraspididae, and Acanthodii occur in fresh water or in marginal marine conditions.

Vertebrates at this locality are unusually well preserved. In many instances the surfaces of slabs of rock are covered with articulated specimens lying on top of one another in an arrangement suggestive of mass mortality (see Pls. 24, 25). There are at least two possible explanations for the mass mortality of vertebrates at this locality. First, it is possible that anaerobic conditions, as witnessed by the high carbon and pyrite content of some layers, were responsible for death of the vertebrates. Second, possible increases in salinity, caused perhaps by tidal flooding, were responsible for killing forms which were at the limits of salt tolerance in a hyposaline lagoon. In support of this argument is the fact that, where the surfaces of slabs bear several specimens, Osteostraci are commonly associated with thelodonts and Heterostraci with acanthodians and *Lepidaspis* (Pl. 30). This might then be interpreted as a selective killing of species according to their salt tolerance.

*Nahanniaspis* and *Dinaspidella* are the most abundant elements of the fauna and it is possible that they lived in schools; *Canadapteraspis* and *Lepidaspis* are also fairly common. *Sigurdia*, *Pionaspis*, and *Poraspis* are less common, and *Aserotaspis* and other heterostracans are rare. Although Osteostraci constitute an important part of the fauna, the collection rarely includes more than one specimen of each type. A few species of generally well-preserved acanthodians are also conspicuous; individuals vary in size from 30 to 100 mm long, and are being studied by G. Bernacsek at the University of Bristol.

Interrelationships between the different organisms at this locality are difficult to envisage without more knowledge of the behaviour and feeding habits of the vertebrates. It is probable that the agnathans were all microphagous bottom-feeders; they would have fed from the muds which, from the high carbon content of the rock, are presumed to have been rich in organic matter. Some forms may have been infaunal, spending part of their existence buried in mud or vegetation litter on the lagoon floor. The acanthodians, being nectonic fishes (Miles 1971), would probably not have competed directly with the agnathans; it is most unlikely that they preyed on them. Like the Late Devonian *Homalacanthus gracilis* (Miles 1966, 1968), they may have fed on ostracods.

GSC 69017      63° 25' N.      128° 00' W.      West of Natla River, 38 m above the base of  
the Delorme Formation.

No section is available for this locality (Gabrielse *et al.* 1973, p. 74). Material was collected from several different horizons (Dineley 1968b).

#### Ostracoderm fauna:

<i>?Traquairaspis poolei</i> sp. nov.	<i>Vernonaspis</i> sp. indet.
<i>?Traquairaspis adunata</i> sp. nov.	<i>Pionaspis amplissima</i> sp. nov.
<i>?Traquairaspis guttata</i> sp. nov.	<i>Archegonaspis</i> sp. indet., Type 2
<i>?Traquairaspis retusa</i> sp. nov.	Cyathaspidinae indet., Type 2
<i>?Traquairaspis pustulata</i> sp. nov.	<i>Poraspis</i> cf. <i>P. polaris</i>
<i>?Traquairaspis broadi</i> sp. nov.	Poraspidinae indet., Type 2
<i>?Traquairaspis mackenziensis</i> sp. nov.	Cyathaspididae indet., Type 1

Traquairaspididae indet., Type 2	Pteraspinae indet.
Traquairaspididae indet., Type 3	<i>Natlaspis planicosta</i> gen. et sp. nov.
Traquairaspididae indet., Type 4	Heterostraci indet., Type 1
<i>Corvaspis</i> sp. indet.	Heterostraci indet., Type 2
<i>Asketaspis interstincta</i> gen. et sp. nov.	Heterostraci indet., Type 4

Material was collected from several different horizons, with '*Traquairaspis*' occurring lower in the sequence than '*Pteraspis*' (Dineley 1968b); material from this locality included scree collections and it is not possible to determine which specimens were from the same horizons. Although this locality lies within the Delorme Formation, no invertebrate fauna is available to support a Late Silurian or an Early Devonian age.

*Traquairaspis* is typically a Silurian or Downtonian heterostracan; although its upper range limit in North America is not yet recognized, it is rare in the post-Downtonian strata of Europe. All reliably dated occurrences of *Vernonaspis* are Silurian. *Pionaspis amplissima* and *Poraspis* cf. *P. polaris* are common to GSC localities 69014, 81052, and 81053, all of which are considered to be of probable Dittonian age; the presence of a large pteraspidid at GSC locality 69017 also reinforces the suggestion of a Dittonian age.

The oldest elements of the collection may be Silurian; the youngest are probably Dittonian and from different levels.

Lithology and invertebrate fauna: Partly dolomitized biomicrite with abundant ostracods and gastropods.

Preservation of ostracoderms: Shields numerous and well preserved but not articulated.

Interpretation of environment: The fine grain size of the original matrix indicates a low-energy environment; the invertebrate fauna, comprising large numbers of few species, suggest hyposaline conditions. The ostracoderms at this locality may also have been inhabitants of a brackish water lagoon; if so, it was apparently better aerated than that at GSC locality 69014.

GSC 75853    63° 33' N.    128° 39' W.    North of June Lake, 550 m above the base of the section. (Formation unknown.)

Ostracoderm fauna:

?*Traquairaspis* cf. ?*T. pustulata* sp. nov.    ?*Traquairaspis lemniscata* sp. nov.

No details of the invertebrate fauna and section are available; the horizon may or may not be within the Delorme Formation.

*Traquairaspis* is typically Silurian or Downtonian, but the upper limit of its range in North America is not yet known. ?*T. pustulata* occurs at GSC 69017 and ?*Traquairaspis* cf. *T. pustulata* at GSC 58497; neither of these occurrences can be accurately dated. ?*T. lemniscata* occurs at GSC 81050, which is regarded as being of Silurian age; the ostracoderm fauna at GSC 75853 may also be Late Silurian.

The two specimens from this locality occur in contrasting lithologies and are therefore considered separately.

(A) NMC 21437

Lithology: Dark, shaly dolomite; no invertebrates known.

Preservation of ostracoderm: A single weathered shield.

Interpretation of environment: Uncertain.

(B) NMC 21448

Lithology and invertebrate fauna: Crinoidal limestone with well-sorted columnals.

Preservation of ostracoderms: A single poorly preserved shield.

Interpretation of environment: High-energy open marine, shallow water.

GSC 81050

Exact co-ordinates uncertain

On a ridge on the south side of June Lake,  
within the Delorme Formation.

The ostracoderm fauna and lithology are very similar to those of the lower of two ostracoderm horizons described by Denison (1964) from Mount Sekwi. Since GSC locality 81050 is also on Mount Sekwi, and *Vernonaspis sekwiae* Denison is common to the two faunas, it is probable that this is the same horizon, if not the same locality. The lower of the two horizons described by Denison is dated as Late Silurian from associated brachiopods and corals.

Ostracoderm fauna:

?Traquairaspis lemniscata sp. nov.

Traquairaspididae indet., Type 1

Ptomaspis cf. *P. canadensis**Vernonaspis sekwiae**Vernonaspis tortuocosta* sp. nov.*Vernonaspis* cf. *V. major**Archegonaspis* sp. indet., Type 3*Archegonaspis* sp. indet., Type 4*Cyathaspis* sp. indet.*Homalaspidella* cf. *H. borealis**Homalaspidella* sp. indet., Types 1-5

*Ptomaspis canadensis* Denison, *Vernonaspis major* Denison, and *Homalaspidella borealis* Denison were originally described from the Beaver River area (Denison 1963); the age of this fauna is concluded to be Late Silurian. The *V. sekwiae* on Mount Sekwi (Denison 1964) is also dated as Late Silurian age; the horizon may be the same as that from which *V. sekwiae* was originally described (Denison 1964).

Lithology and invertebrate fauna: Partly dolomitized, orange-weathering, bioclastic limestone containing skeletal debris of articulate and inarticulate brachiopods, gastropods, trilobites, bryozoa, corals, and ostracods.

Preservation of ostracoderms: Disarticulated but unabraded shields are numerous and randomly orientated.

Interpretation of environment: The invertebrate fauna and lithology are indicative of high-energy, shallow-water, marine conditions. Postmortem transport was vigorous, brief, and over a short distance, perhaps from a lagoon locally across a bar into open water.

GSC 81051      Exact co-ordinates uncertain      Broken Skull River.

No section is available for this locality. The lithology and fauna are very similar to those at GSC locality 69014, and the fauna at this locality is assumed to be the same age.

Ostracoderm fauna:

*Pionaspis amplissima* sp. nov.      *Nahanniaspis mackenziei* gen. et sp. nov.  
*Dinaspidella* sp. indet.      *Lepidaspis serrata* gen. et sp. nov.

The four ostracoderms here are also found at GSC 69014. Correlation of the two localities is also suggested by the lithology; at both, well-preserved specimens occur in a dark, laminated, pyritic dolomite. The absence of other elements of the fauna from GSC 69014 is thought to be the result of the small size of the collection and not of an important faunal difference. It is concluded that the ostracoderm horizon at GSC 81051 is of early Dittonian age.

Lithology and invertebrate fauna: Laminated, shaly, pyritiferous dolomite with abundant ostracods.

Preservation of ostracoderms: Articulated and disarticulated plates.

Interpretation of environment: The lithology, ostracoderm fauna, and probably the environment at this locality closely resemble those at GSC 69014.

GSC 81052      Exact co-ordinates uncertain      60 m from the summit of the north flank of a ridge, immediately south of GSC 69017, within the Delorme Formation.

Lithology (localities 81052 and 81053): Fine-grained massive dolomite with no invertebrates.

Ostracoderm fauna:

*Pionaspis amplissima* sp. nov.      Pteraspidinae indet.  
*Poraspis* cf. *P. polaris*

Although this locality is within the Delorme Formation, no information concerning the section or invertebrate faunas is currently available. *Pionaspis amplissima* and *Poraspis* cf. *P. polaris* occur at GSC 69014, 69017, and 81053, all of which are of Dittonian age. The presence of Pteraspidinae here also supports a Dittonian age.

GSC 81053      Exact co-ordinates uncertain      As for GSC 81052, but on the south flank of the ridge, 60 m along the strike.

Ostracoderm fauna:

*Pionaspis amplissima* sp. nov.      *Canadapterspis helostomata* gen. et sp. nov.  
*Poraspis* cf. *P. polaris*      Heterostraci indet., Type 6  
*Canadapterspis thymostomata* gen. et sp. nov.

*Pionaspis amplissima* and *Poraspis* cf. *P. polaris* are common to GSC 69014, 69017, and 81052; Heterostraci indet., Type 6 also occurs at GSC 69014. Additional support for a Dittonian age for the fauna at GSC 81053 is provided by the presence of large pteraspids.

Preservation of ostracoderms: Well-preserved, disarticulated shields.

Interpretation of environment: As for GSC 69017.

Ostracoderm fauna:

<i>Poraspis</i> cf. <i>P. polaris</i>	Thelodontida indet.
Pteraspidaenae indet.	<i>Lepidaspis serrata</i> gen. et sp. nov.

*Poraspis* cf. *P. polaris* and *Lepidaspis serrata* are common to GSC locality 69014, as are thelodonts and pteraspidaenae. Although the ostracoderm assemblage is probably of Dittonian age, its abraded and comminuted state suggests that it is a product of reworking.

Lithology and invertebrate fauna: Sandy, fine-grained limestone with ostracods and shale pellets.

Preservation of ostracoderms: Abraded, comminuted debris and isolated denticles.

Interpretation of environment: This material all appears to have been reworked, with movement vigorous enough to smash carapaces. Shale pellets may be rip-up clasts derived from mud flats by sudden floods.

GSC 81057	Exact co-ordinates uncertain	This locality appears to be wrongly numbered; according to the Geological Survey of Canada, the number refers to a Cambrian formation in British Columbia.
-----------	------------------------------	--

*Chevron Standard localities.* The measured sections for each of the Chevron Standard localities were made available by D. W. Organ, Chief Geologist of the Chevron Standard Co. Lists accompanying these sections were the source of the following details and age determinations for the associated invertebrate faunas.

CS YA17	62° 42' N.	127° 53' W.	1.6 km north of Grizzly Bear Lake. Horizons 8F and 9F are both within the Delorme Formation.
---------	------------	-------------	--

Horizon 8F has yielded fauna including *Lingula*, *Conchidium*, and indeterminate rhynchonellids which were interpreted as indicative of a probable Late Silurian age. Horizon 9F occurs approximately 40 m above Horizon 8F and approximately 665 m stratigraphically below a horizon containing the Early or Middle Devonian *Xystriphyllum*. Horizon 9F may be of Late Silurian or Early Devonian age.

(Horizon 8F): Ostracoderm fauna: Cyathaspididae indet.

The ostracoderm fauna is of no stratigraphic value.

Lithology and invertebrate fauna: Micrite with pellets, bryozoa, and crinoid columnals.

Preservation of ostracoderms: Numerous disarticulated and fragmented shields.



Interpretation of environment: Shallow water, marine conditions, as for YA20.

(Horizon 9F): Ostracoderm fauna: Cyathaspididae indet.

Neither the ostracoderms nor the invertebrate fauna are of value for determination of the precise age of the ostracoderm horizon; it may be Late Silurian or Early Devonian.

Preservation of ostracoderms: Single plate fragment.

Lithology: Fine-grained, thinly laminated, sandy limestone with mica flakes.

Interpretation of environment: Not unlike preceding localities but with detritus introduced from (outside) beaches, rivers, or other areas.

CS YA20      63° 12' N.      128° 30' W.      40 km south-east of June Lake. Horizon 16F, within the Whittaker F Formation, is 325 m below the base of the Delorme Formation.

Present in the same horizon are Late Silurian species of *Encrinurus*, *Atrypella*, *Ketophyllum*, and '*Dokophyllum*'.

Ostracoderm fauna: *Ariaspis* cf. *A. ornata*

*Ariaspis ornata* was originally described from the Beaver River area of south-eastern Yukon (Denison 1963), and is now regarded as Late Silurian.

Lithology and invertebrate fauna: Micrite with bryozoa, conodonts, and crinoid columnals.

Preservation of ostracoderms: A single well-preserved shield.

Interpretation of environment: Shallow water, marine conditions, with not insignificant movement of water by tides, waves, currents, or storms.

CS YB1      62° 24' N.      127° 18' W.      4 km west-south-west of Jade Lake. Horizon 4F is at 625 m in the section. (Formation unknown.)

It lies approximately 210 m stratigraphically above a horizon with Early or earliest Middle Silurian graptolites, and 43 m below a horizon with *Monograptus* similar to the *praehercynicus* or *uniformis* type. Since the latter was regarded as Late Silurian or earliest Devonian in age, the ostracoderm horizon is probably Late Silurian.

Ostracoderm fauna: *Vernonaspis* cf. *V. sekwiae*

Reliably dated occurrences of *Vernonaspis* are all Silurian; *V. sekwiae* occurs on Mount Sekwi (Denison 1964; see above, GSC locality 81050), at a horizon dated as Late Silurian. The position of Horizon 4F, below a Late Silurian or earliest Devonian graptolite fauna, suggests a Late Silurian age.

Lithology and invertebrate fauna: Micrite with shell fragments and rare crinoid columnals.

Preservation of ostracoderms: Disarticulated shields distorted but very abundant.

Interpretation of environment: Shallow marine conditions, like YA20.

CS YB10      63° 40' N.      129° 23' W.      40 km north-west of June Lake. Horizon 9F  
(Horizon 9F)      is at 340 m in the section. (Formation unknown.)

The ostracoderm horizon occurs 110 m stratigraphically above a horizon containing Early Ordovician graptolites, and approximately 244 m below a horizon containing *Atrypa reticularis* cf. var. *niecslaviensis*, *Encrinurus*, *Syringopora*, ?*Stropheodonta* cf. *subinterstriatus serentis* which are interpreted as of Late Silurian or Early Devonian age. It is probable that Horizon 9F is within the Silurian.

Ostracoderm fauna:

Traquairaspididae indet.      *Tolypelepis lenzi* sp. nov.

*Tolypelepis* may range from the Llandoveryan to the Early Devonian.

Lithology and invertebrate fauna: Micrite with shell fragments and crinoid columnals.

Preservation of ostracoderms: Single well-preserved shields.

Interpretation of environment: Shallow marine conditions, as for YA20.

CS YEx37b      62° 35' N.      127° 45' W.      16 km south of Grizzly Bear Lake: spot  
locality. (Formation unknown.)

Ostracoderm fauna: Cyathaspididae indet.

No invertebrates were collected from this locality; cyathaspidids indicate a Silurian or Early Devonian age.

Lithology: Thinly bedded, yellow-weathering, fine-grained dolomite.

Preservation of ostracoderms: Disarticulated shields.

Interpretation of environment: As for YE41.

CS YE41      62° 36' N.      127° 47' W.      8 km south of Grizzly Bear Lake. Horizon 3F  
(Horizon 3F)      is at 61 m in the section. (Formation unknown.)

Ostracoderm fauna: Cyathaspididae indet.

No invertebrates are known from this section; cyathaspidids indicate a Silurian or Early Devonian age.

Preservation of ostracoderms: Rare, incomplete shields.

Interpretation of environment: Perhaps a rather anaerobic area of still water with rare influxes of silt and organic debris.

CS YG1 (Horizon 6F)                      129° 21' W.                      35 km west-north-west of June Lake. Horizon 6F is at 115 m and Horizon 9F at 159 m in the section. (Formation unknown.)

Ostracoderm fauna:

Traquairaspididae indet.                      Cyathaspididae indet.  
Cyathaspidinae indet., Type 5

Invertebrates within this section imply an earliest Devonian age. Horizon 6F was dated as Late Silurian on the basis of the conodonts *Plectospathodus flexuosus*, *P. extensus*, *Spathognathodus primus*, *Hindeodella* sp., and *?Ozarkodina* sp. Horizon 6F is of probable Early Devonian age. It occurs 14 m stratigraphically below a horizon with Early or Middle Devonian invertebrates: *Hemiarges*, *Piriproetus*, *?Rhyncospirina*, *Atrypa*, *Sieberella* or *?Gypidula*, spiriferid cf. *Fimbrispirifer*, and 16 m stratigraphically above a horizon with *Nucleospira* and *Septatrypa* cf. *secreta*, which may point to an earliest Devonian age; the *Traquairaspis*-Cyathaspidinae assemblage is more typical of the Downtonian than the Dittonian in Europe.

Lithology and invertebrate fauna: Nodular limestone with shell fragments.

Preservation of ostracoderms: Disarticulated shields.

Interpretation of environment: Probably shallow marine conditions, with organic fragments introduced by a low level of current or stream activity.

CS YG1 (Horizon 9F):

Ostracoderm fauna: Cyathaspididae indet.

The cyathaspidids are suggestive of a Silurian or Early Devonian age; associated conodonts are Late Silurian.

Lithology and invertebrate fauna: Sparry and micritic, crinoidal limestone with shell fragments and pellets.

Preservation of ostracoderms: Disarticulated shields.

Interpretation of environment: Shallow, high-energy, marine conditions, perhaps not far from the littoral or lagoonal areas.

Material from the District of Mackenzie supports the view that some Late Silurian Heterostraci were marine but that others probably occupied brackish lagoons or other marginal marine environments.

The Early Devonian ostracoderm assemblage at GSC locality 69014, although resembling that of Old Red Sandstone facies, is preserved in laminated dolomite and thought to have inhabited a hyposaline lagoon with fluctuating salinity.

## SYSTEMATIC PALAEOONTOLOGY

Palaeozoic agnathans are commonly grouped together as ostracoderms, and living forms as cyclostomes, but these associations are at least to some extent artificial. It is now generally agreed that the relationship of the Heterostraci to the Cyclostomata,

Osteostraci, and Anaspida is not close (Kiaer 1932; White 1935; Obruchev 1945; Wangsjö 1952; Watson 1954; Balabay 1956; Tarlo 1962*a*; Heintz 1962; Denison 1964; Miles 1971). Stensiö (1958) has none the less cited numerous characters in which the Heterostraci were supposed to resemble cyclostomes in general and myxinooids in particular. The classification used here is that proposed by Denison (1964) and subsequently used in a slightly different form by Miles (1971).

Class Agnatha

Subclass Diplorhina (= Pteraspidomorphi)

Order Heterostraci

Order Thelodontida (= Coelolepida)

Subclass Monorhina (= Cephalaspidomorphi)

Superorder Hyperotreti

Order Myxinoidea

Superorder Hyperoartii

Order Petromyzonida

Order Osteostraci

Order Anaspida

The agnathans are characterized by the absence of true gill-arch jaws, the development of which was regarded by Jarvik (1964, 1968) as having been prohibited by the position of the gills on the inner face of the gill-arches. The cephalaspidomorphs, which apparently form a natural group, have a single nasohypophysial opening and numerous gills; the lampreys and hagfishes are distinct fishes with long and separate histories (Miles 1971, p. 56). Miles (1971, p. 36) questioned the grouping of the thelodonts with heterostracans but concluded that, if they were to be regarded as a natural group, they could best be defined as agnathans with paired nasal sacs and openings, no nasohypophysial duct, and the rostral region formed by the (morphologically) anterior part of the head.

Nearly all recent attempts at the interpretation of heterostracan growth and phylogeny have involved the 'Lepidomorial Theory' developed by Ørvig and Stensiö (Ørvig 1951) on the basis of studies of elasmobranch scales. It postulates the essential (primitive) element of the exoskeleton as the 'lepidomorium', a crown of dentine and a low basal plate containing a single pulp cavity. Individual lepidomoria could not increase in areal extent, but groups of them could grow in one of the following ways: (1) Lepidomoria unite at the base, but their pulp cavities remain separate, discrete lepidomoria being added around the primordium to give a growing 'cyclomorial unit'. (2) Lepidomoria fuse prior to calcification, forming a 'synchronomorial unit' with a compound pulp cavity. Various combinations of these two types of growth were said to be possible, synchronomorial primordia for example, growing cyclomorially by the addition of further synchronomorial units.

To Stensiö (1958) the differences between heterostracan families were the result of fusion of larger with smaller dermal elements, the Cyathaspididae being considered to be the most advanced by virtue of the presence of large, undivided shields.

The types of growth recognized by Stensiö could perhaps be derived from one another (Tarlo 1960), and Tarlo (1962*a, b*) proposed that different evolutionary lines of heterostracans passed through comparable stages in the evolution of the

carapace. Each involved a progressive elimination of the primitive tessellated pattern. Four distinct lineages were envisaged—psammosteid, pteraspidid, cyathaspidid, and amphiaspidid. Later members of the Psammosteidae, however, display a reversal of the trend towards fusion and are covered with (superficial) tesserae.

Alternative views have been expressed by Obruchev (*in* Tarlo 1961), Westoll (1967), and Denison (1964). Westoll in particular urged study of the ontogenetic sequence of events in the growth of carapaces for clues as to evolutionary trends. He also suggested that there was considerable independence between the superficial layer (including tesserae) and the deeper dermal structures.

In his most recent work on the subject, Tarlo (as Halstead 1973) advanced a new synopsis of heterostracan evolution, taking into account more recently published material. He recognizes two distinct lineages derived from the tessellated *Tesseraspis*. One lineage via the partly tessellated *Weigeltaspis* produced psammosteids, traquairaspids, and finally the non-tessellate pteraspidids. The other lineage through *Kallostrakon* and *Corvaspis* gave rise to the partly tessellated *Cardipeltis* and later to the non-tessellate cyathaspidids and amphiaspids. The scheme is superficially attractive in its orderly and simple progression of forms from tessellate through the partly tessellate to the non-tessellate, but the stratigraphic distribution of the fossils so far known does not uphold the sequence. 'Primitive' cyathaspids and traquairaspids, for example, occur much earlier than *Tesseraspis* or *Kallostrakon*.

There are major drawbacks to strict applications of the lepidomorial theory. One (Denison 1964; Westoll 1967) emphasizes that evolutionary changes within the skeleton probably involved both the subdivision and the assimilation of bones, and that advancement cannot be gauged simply by the degree to which fusion has progressed. Another problem is that of the extent to which the pattern of the superficial dentine ornamentation reflects the way in which the shield actually grew. Denison (1964, pp. 154–155), criticizing Stensiö (1958) for basing his description of growth in *Tolypelepis* on ridge pattern alone, preferred a number of alternative interpretations. Denison later (1973) concluded that, in both the Cyathaspidae and the Pteraspidae, the superficial dentine ridges and grooves do not indicate growth stages but simply reflect soft structures which were present in the skin prior to mineralization of the shield. In some cyathaspids at least (Denison 1964) the superficial and deeper layers of the shield form independently, and the implications of this have been examined by Westoll (1967).

The cyathaspids from the Mackenzie Mountains reveal that, in spite of the 'synchronomorial' pattern of the dentine ridges, the superficial layer of the shield apparently grew concentrically from several growth centres which, in the Cyathaspidae, correspond to the epitega. The lack of growth lines on the internal surface of the shield supports Denison's view (1964) that the deeper layers of the shield developed only when the individual reached full size.

If this interpretation of cyathaspid growth is correct, the Pteraspidae may show an advance in being able to develop the deeper layers of the bone at an early stage and may do so in units capable of increasing in area (Denison 1973). Westoll (1967) suggested that the pteraspid pattern of growth was established by the development, in the epitega of the cyathaspids, of the morphogenetic capacity to induce the formation of separate dermal bones in the deeper dermis. This idea will

merit further consideration when more is known of the ontogeny of other heterostracans and the relationships between families are better understood.

It is therefore thought best to apply the lepidomorial theory only to the elasmobranchs. Its value in the Heterostraci is limited to situations where its terminology can be used to describe patterns of growth which have been analysed other than by interpretations of ridge pattern, as in Denison (1973). Throughout the following pages, the terms 'cyclomoriform' and 'synchronomoriform' are used to describe ridge patterns which suggest, but by no means prove, cyclomorial and synchronomorial growth patterns.

The material described in this paper is deposited in the National Museum of Canada, Ottawa, and bears catalogue numbers (prefixed NMC) of the Museum's vertebrate palaeontology collection.

ORDER HETEROSTRACI LANKESTER, 1886  
FAMILY TRAQUAIRASPIDIDAE KIAER, 1932

*Diagnosis.* Dorsal shield comprises either a single plate enclosing orbital, branchial, and pineal openings, or an assembly of seven or nine minor plates (paired orbital and branchio-cornual or branchial and cornual plates and unpaired dorsal disc, rostral and pineal plates). Ornamentation of dorsal shield commonly of elevated, laterally serrated tubercles and narrow, interstitial ridges arranged in small cyclomoriform units, which may form elevated crests or spines on the posterior part of the shield. Ventral disc oval to elongate, with lateral ornamentation similar to that of dorsal shield. Ornamentation broader and flatter toward longitudinal mid-line of shield or replaced by a smooth oval area (ventral primordium). Lateral line system variable, from simple pattern of longitudinal canals and transverse commissures to complex anastomosing network.

*Genera.* *Traquairaspis* Kiaer, 1932; *Yukonaspis* Obruchev, 1964.

*Remarks.* The family Traquairaspididae was established by Kiaer (1932) to receive *T. campbelli* (Traquair) from Scotland, a species which had originally been referred to *Cyathaspis*. White (1950a), realizing that specimens which he had described as *Phialaspis pococki cowiensis* (White 1946) were ventral discs of *T. campbelli*, referred *P. pococki* White and *P. symondsi* Wills, from the Downtonian or the Anglo-Welsh borderlands, to the genus *Traquairaspis*.

A ventral shield of *T. angusta* Denison (1963) was regarded by Obruchev (1964) as sufficiently different from other members of the genus *Traquairaspis* to warrant the establishment of the genus *Yukonaspis* for its reception. In 1964 Dineley described a new species, *T. denisoni*, from British Columbia. Broad (1971), in an as yet unpublished taxonomic revision of the Traquairaspididae, proposed three subfamilies, each characterized by its lateral line system.

The Mackenzie Mountains material, mostly isolated plates and fragments, has been prepared by the 'transfer method' (Toombs and Rixon 1950), but it remains opaque. X-ray pictures, kindly provided by Dr. D. Poole of the Medical Research

Council Dental Unit of the Bristol Dental School, reveal nothing further of the lateral line canals. Specimens are too few to allow an attempt to develop the lateral line canals by etching or grinding.

Until the lateral line systems of the new species of traquairaspidid described below are known, these species are referred to *?Traquairaspis*. The shape and pattern of the dentine ridges, which are amongst the few available criteria for comparison of the traquairaspidids, are regarded by Broad (1971) as generally unreliable for specific determination. The new species have therefore been established on the basis of the shape of dorsal or ventral shields, the extent of fusion of the dorsal disc to adjacent dorsal plates, and on the ornamentation, particularly that of the ventral disc. Specimens from the District of Mackenzie exhibit a far greater variety of ventral ornamentation than material previously described. Poorly preserved material which can be characterized only by ornamentation is referred to Traquairaspididae indet. and distinguished, where possible, as Types 1-4.

It is acknowledged that, since some forms are described from dorsal and others from ventral discs, two species or types may subsequently be found to be parts of the same animal.

*?Traquairaspis poolei* sp. nov.

Plate 1, fig. 3; text-fig. 2

*Derivation of name.* After Dr. D. F. G. Poole, of the Medical Research Council Dental Unit, Dental School, Bristol.

*Diagnosis.* Small traquairaspidid with branchio-cornual? plates (and probably other dorsal plates) fused to the dorsal disc. Ornamentation of cyclomoriform units, the central tubercles of which are short, with finely serrated lateral margins, the interstitial ridges of which are narrow and closely spaced, being subdivided into short lengths toward the anterior and posterior ends of each unit. Posterior margin of dorsal disc formed by five exceptionally large cyclomoriform units.

*Holotype.* NMC 21395, an incomplete dorsal shield (Pl. 1, fig. 3; text-fig. 2).

*Other material.* NMC 21396, an incomplete dorsal shield.

*Locality.* GSC 69017.

*Description.* The rather small dorsal disc (estimated size 30 mm long  $\times$  25 mm wide) has an ornament of numerous, small, cyclomoriform units. Each unit comprises a central, elevated, laterally serrated, lachrymiform tubercle, around which narrow ridges are concentrically arranged. The central tubercles are 0.5-1.5 mm long and up to 0.5 mm wide, their narrow ends being anteriorly directed. The narrow interstitial ridges are also laterally serrated and have an average density of ten ridges per mm; toward the anterior and posterior ends of each unit they are subdivided into short lengths. Five exceptionally large cyclomoriform units, with central tubercles up to 3 mm long, form the posterior border of the shield (text-fig. 2). A lateral flange, 2 mm wide, is preserved on the antero-lateral border of both specimens; its ornamentation is of long, narrow (ten per mm), parallel ridges with lateral

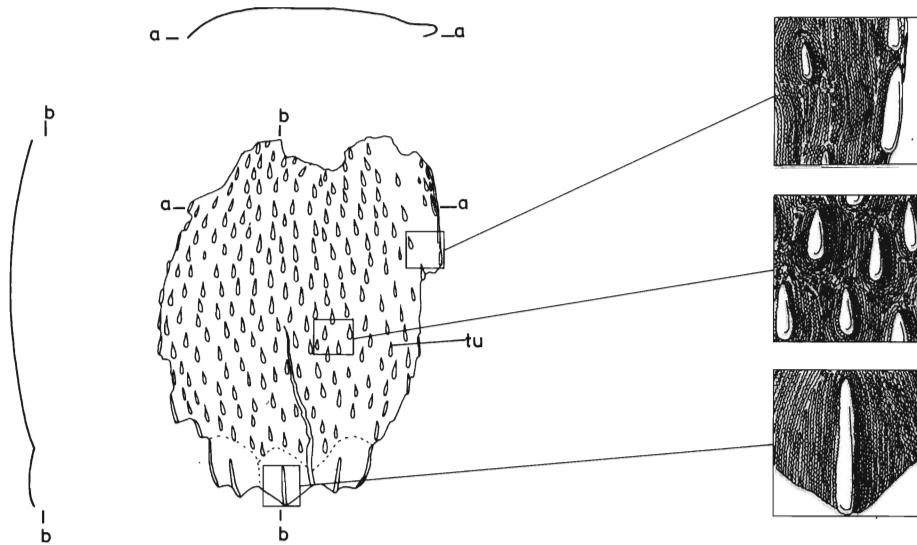

TEXT-FIG. 2. *?Traquairaspis poolei* sp. nov., variation in ornamentation of dorsal shield (NMC 21395, holotype); plan view  $\times 1.875$ , detail  $\times 7.5$ . *a-a*, *b-b* lines of cross-section; *tu*, lachrymiform tubercle.

serrations; lachrymiform tubercles occur only on the extreme lateral margin, where they are long and closely spaced.

*Remarks.* The cyclomoriform ornamentation of finely serrated ridges and tubercles indicate a member of the Traquairaspididae but, since the lateral line system is not visible, it cannot with certainty be ascribed to a smaller taxon. It is referred to *?Traquairaspis*, with other material from the District of Mackenzie.

Towards the anterior and posterior ends of each cyclomoriform unit, irregular areas of short interstitial ridges resemble the 'rhombic areas' found in material from the Arctic islands. Broad (1971) thought such ridges formed during growth of the shield as the individual cyclomoriform units moved apart. Since it is not possible to demonstrate that *?T. poolei* did grow, its 'rhombic areas' could be relics of an earlier evolutionary stage.

Although the lateral flange has no distinct commissure with the dorsal disc, it appears from its shape, position, and ornamentation to be equivalent to the branchial or branchio-cornual plate of other members of the family (White 1946). The shield is too incomplete to reveal whether the dorsal armour comprised a single plate; in *?T. adunata* sp. nov. and *?T. mackenziensis* sp. nov. a single dorsal plate covers the area which may be protected by seven to nine separate plates in other forms.

*?T. poolei* is distinguished from other species by its small size, its 'rhombic areas', and the presence of a posterior border of enlarged cyclomoriform units on the dorsal disc.



*?Traquairaspis adunata* sp. nov.

Plate 1, figs. 2, 5; text-fig. 3

**Diagnosis.** Dorsal shield small (estimated length 45 mm), and not subdivided into the seven plates typical of some other members of the family. Orbits entirely enclosed; pineal foramen situated behind interorbital line. Ornamentation of cyclomoriform units each centred on a lachrymiform tubercle; rostral and lateral margins with broad, closely spaced ridges and tubercles; dorsal, postero-median crest formed by alignment of cyclomoriform units. Ornamentation of high relief.

**Holotype.** NMC 21402, incomplete dorsal shield (Pl. 1, fig. 5; text-fig. 3).

**Paratype.** NMC 21397, incomplete dorsal shield (Pl. 1, fig. 2).

**Material.** NMC 21398-21401, 21403-21404, incomplete dorsal shields.

**Locality.** GSC 69017.

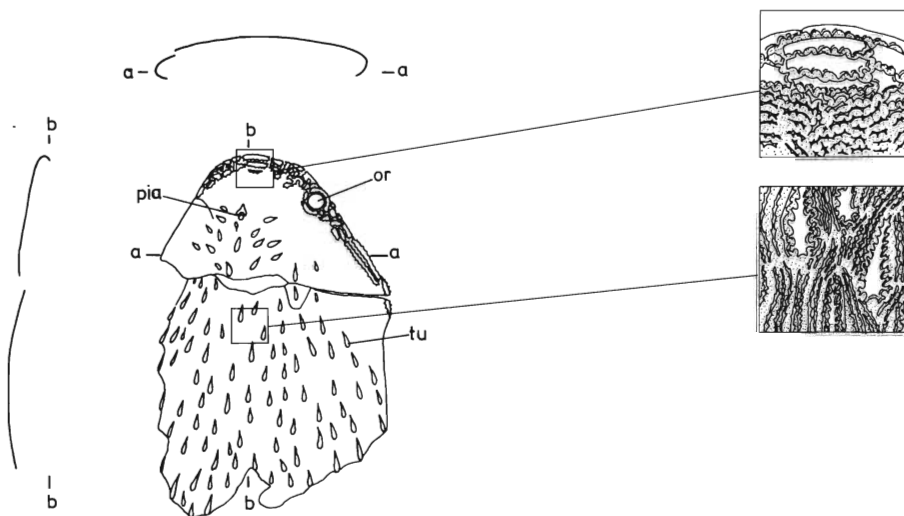

TEXT-FIG. 3. *?Traquairaspis adunata* sp. nov., variation in ornamentation of dorsal shield (NMC 21402, holotype); plan view  $\times 1.875$ , detail  $\times 7.5$ . *a-a*, *b-b*, lines of cross-section; *or*, orbit; *pia*, pineal area; *tu*, lacrymiform tubercle.

## EXPLANATION OF PLATE 1

- Fig. 1. *Traquairaspis retusa* sp. nov. Incomplete dorsal disc (NMC 21422, holotype),  $\times 2.5$  (see text-fig. 5).  
 Fig. 2. *Traquairaspis adunata* sp. nov. Incomplete dorsal shield (NMC 21397, paratype),  $\times 2.5$ .  
 Fig. 3. *Traquairaspis poolei* sp. nov. Incomplete dorsal shield (NMC 21395, holotype),  $\times 2.5$  (see text-fig. 2).  
 Fig. 4. *Traquairaspis guttata* sp. nov. Incomplete ventral shield (NMC 21411, holotype),  $\times 2.5$  (see text-fig. 4).  
 Fig. 5. *Traquairaspis adunata* sp. nov. Incomplete dorsal shield (NMC 21402, holotype),  $\times 2.5$  (see text-fig. 3).

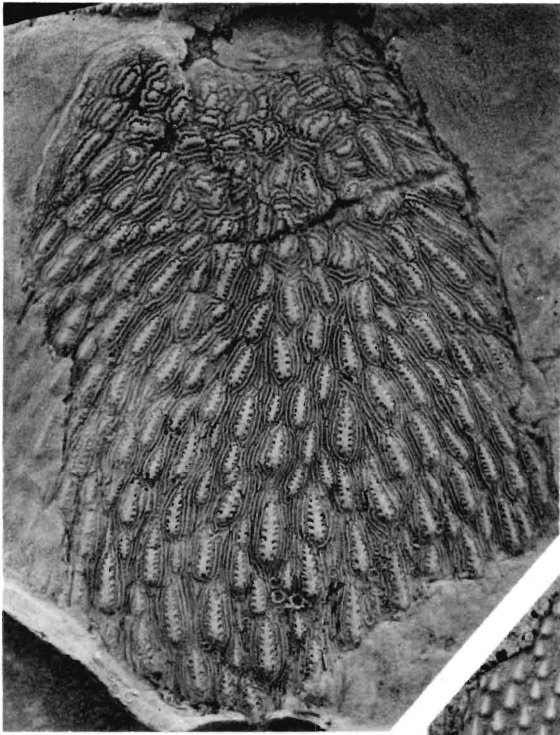

1

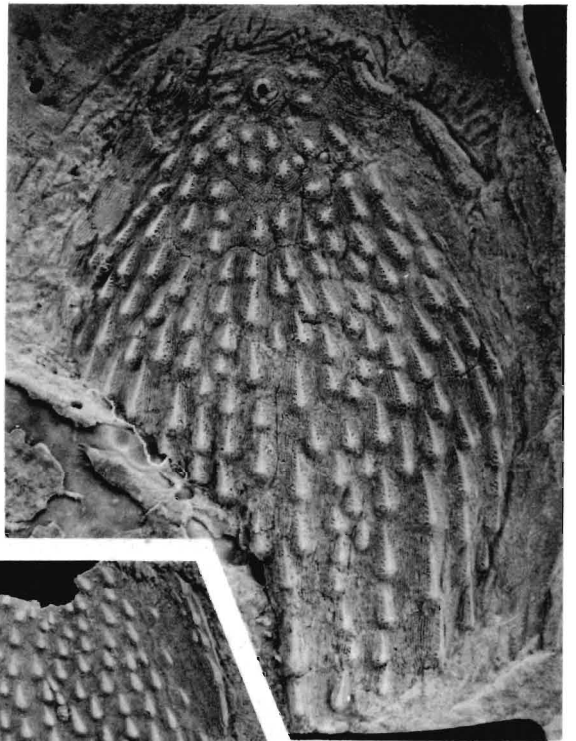

2

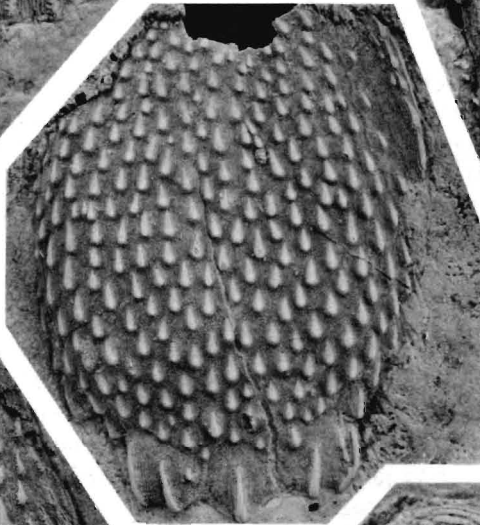

3



4

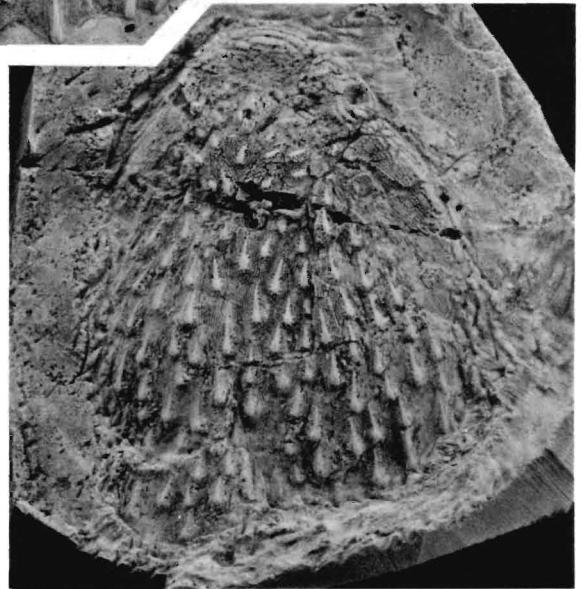

5

*Description.* The dorsal shield, which is estimated to have been approximately 45 mm long and 25 mm wide, is made up of a single plate; although regions of the shield can be distinguished by their ornamentation, there are no distinct boundaries or sutures. The central region has an ornament of cyclomoriform units, each of which is centred on an elevated, lachrymiform tubercle. These tubercles are 0.8–2.0 mm long and have U-shaped indentations around their broad, posterior ends and forwardly directed projections around their narrower, anterior ends. Concentrically arranged about each tubercle are several narrow, twig-like ridges, with a density of ten ridges per mm; each has a narrow central axis and short, simple, lateral branches. On the central region of the dorsal disc, cyclomoriform units converge anteriorly and are longitudinal posteriorly; several cyclomoriform units produce a low median crest on the posterior part of the shield (Pl. 1, fig. 5). A lateral border (2.5–5.0 mm wide), where ornamentation is largely of long, parallel, twig-like ridges, probably corresponds to the branchial or branchio-cornual plate of other forms; long (up to 4 mm), broad (0.25 mm) ridges and tubercles are closely grouped on the lateral margin of the shield. The apparent absence of a branchial opening may be due to poor preservation.

Each small (diameter 1.6 mm), antero-laterally placed orbit is bordered by several broad (0.3 mm) ridges with a concentric arrangement; ridges of similar width are transversely arranged on the gently rounded rostral margin. Immediately behind the interorbital line, the shield is perforated by a small (diameter 0.5 mm) pineal foramen, enclosed by a wide (0.25 mm) annular ridge, which has a serrated peripheral margin and is surrounded by narrow, concentrically arranged, twig-like ridges. Anterior to the pineal foramen, cyclomoriform units are arranged transversely or in a pattern resembling a broad fan.

*Remarks.* *?Traquairaspis adunata* resembles *?T. mackenziensis* in that the dorsal shield is a single unit, in which the separate dorsal plates of other forms can be distinguished only by slight differences in ornamentation. Another feature shared by these species is the possession of a pineal foramen; with the noteworthy exception of *Natlaspis planicosta* gen. et sp. nov. (p. 140 below), this is a feature otherwise unknown in the Heterostraci.

*?T. adunata* is distinguished from *?T. mackenziensis* not only by its smaller size, but also by details of ornamentation; the orbital and lateral, but not the dorsal, ornamentation is of lower relief than that of *?T. mackenziensis*.

*?Traquairaspis guttata* sp. nov.

Plate 1, fig. 4; text-fig. 4

*Diagnosis.* Small (40 mm long × 27 mm wide) ventral shield lacking a ventral primordium and having a ventral ornamentation of cyclomoriform units, the central tubercles of which are broad and flat near the longitudinal mid-line of the shield.

*Holotype.* NMC 21411, an incomplete ventral shield (Pl. 1, fig. 4; text-fig. 4).

*Other material.* NMC 21407–21409, 21412, incomplete ventral shields.

*Locality.* GSC 69017.

*Description.* The holotype is approximately 40 mm long and 27 mm wide. The ventral

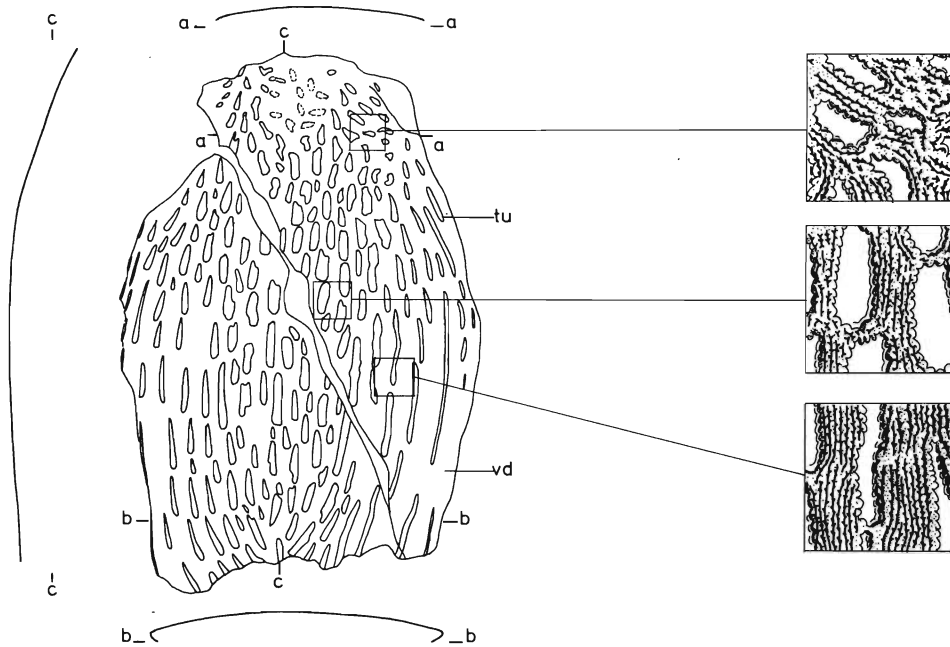

TEXT-FIG. 4. ?*Traquairaspis guttata* sp. nov., variation in ornamentation of ventral shield (NMC 21411, holotype); plan view  $\times 1.875$ , detail  $\times 7.5$ . *a-a*, *b-b*, *c-c*, lines of cross-section; *tu*, serrated lachrymiform tubercle; *vd*, ventral disc.

shield, which is more vaulted posteriorly than anteriorly, is narrowest several millimetres behind the incomplete anterior margin; the posterior margin is not known.

Ornamentation is of cyclomoriform units, each of which comprises a central, elevation, lachrymiform tubercle with short, anteriorly directed, lateral processes, surrounded by concentrically arranged, narrow, twig-like ridges with a density of nine per mm (text-fig. 4). The lachrymiform tubercles vary in width across the shield; medial tubercles are short (1.2–1.6 mm) and broad (0.75–1.0 mm), but pass laterally into longer (1.2–3.5 mm), narrower (0.2–0.4 mm) tubercles. Narrow (0.2–0.4 mm) ridges, up to 15 mm long, form longitudinal crests close to the lateral margins of the shield separating the almost vertical, lateral faces from the rest of the ventral shield. The concentric arrangement of the interstitial ridges around the lachrymiform tubercles is more marked at the centre of the ventral shield than at the lateral margins, where ridges have a more longitudinal arrangement. Cyclomoriform units have a largely longitudinal arrangement on the shield, except for anterior convergence and irregularity.

The dorsal shield of this species has not been recognized.

*Remarks.* The ornamentation of cyclomoriform units centred on serrated lachrymiform tubercles indicates the Traquairaspididae; the shape of the plates suggests ventral rather than dorsal discs. Ventral ornamentation in the Traquairaspididae is typically an ornamented or unornamented primordium, bordered by cyclomoriform units; tubercles which broaden toward the mid-line of the shield have not previously

been recorded. Ornamentation of the latter type is, however, common amongst traquairaspidids from this locality, also being known in *?T. broadi* and *?T. pustulata*. It seems probable that the same stimulus produced both the ventral primordium and the flattened, broad tubercle; see below (p. 43). As no articulated dorsal or ventral shield is known, it is possible that *?T. guttata* is the ventral shield of a species which has been described from dorsal shields only. *?T. guttata* differs from *?T. broadi* and *?T. pustulata* in its smaller size and in details of ventral ornamentation.

*?Traquairaspis retusa* sp. nov.

Plate 1, fig. 1; text-fig. 5

*Diagnosis.* Moderate-sized traquairaspidid with dorsal disc not fused to adjacent plates. Ornament of cyclomoriform units, the central tubercles of which have bi- and tri-lobed lateral processes. Dorsal disc with broad, shallow, indentation in anterior margin; narrow anterior and antero-lateral border of short (0.5 mm), narrow (0.25 mm) ridges arranged parallel to disc margin.

*Holotype.* NMC 21422, incomplete dorsal disc (Pl. 1, fig. 1; text-fig. 5).

*Other material.* NMC 21410, 21413, 21414, incomplete dorsal discs.

*Locality.* GSC 69017.

*Description.* The holotype (NMC 21422) is the anterior part of a dorsal disc, estimated to have had a length of 40 mm and a width of 30 mm. The disc, which is more vaulted posteriorly than anteriorly, has a wide (9 mm), shallow (3 mm) indentation in the anterior margin.

Ornamentation is of cyclomoriform units, each of which is centred on a large tubercle (1.5–3.5 mm long  $\times$  1.0 mm wide). These tubercles, which are only slightly lachrymiform, have deep, U-shaped indentations in their lateral margins; the lateral projections, between the indentations, commonly terminate in bi- or tri-lobed processes. Between the tubercles are narrow interstitial ridges with a density of seven to eight per mm. The majority of the interstitial ridges are long and narrow (5.0 mm long  $\times$  0.1 mm wide) with short lateral processes. Adjacent to the lachrymiform tubercles, interstitial ridges are divided into short lengths (2–3 mm) and have long lateral processes extending into the U-shaped indentations of the central tubercles. Interstitial ridges have a concentric arrangement about each lachrymiform tubercle. The anterior and antero-lateral margins of the dorsal disc have a narrow border (2 mm wide), upon which narrow (0.25 mm), short (0.5 mm) ridges are arranged parallel to the margin.

*Remarks.* The shape of the dorsal disc and of the central tubercle of each cyclomoriform unit is sufficient to differentiate this traquairaspidid from established species. The broad, anterior indentation may have housed a pineal plate.

*?Traquairaspis pustulata* sp. nov.

Plate 2, fig. 1; text-fig. 6

*Diagnosis.* Ventral shield long (75 mm) and wide (45 mm) with convex lateral margins.

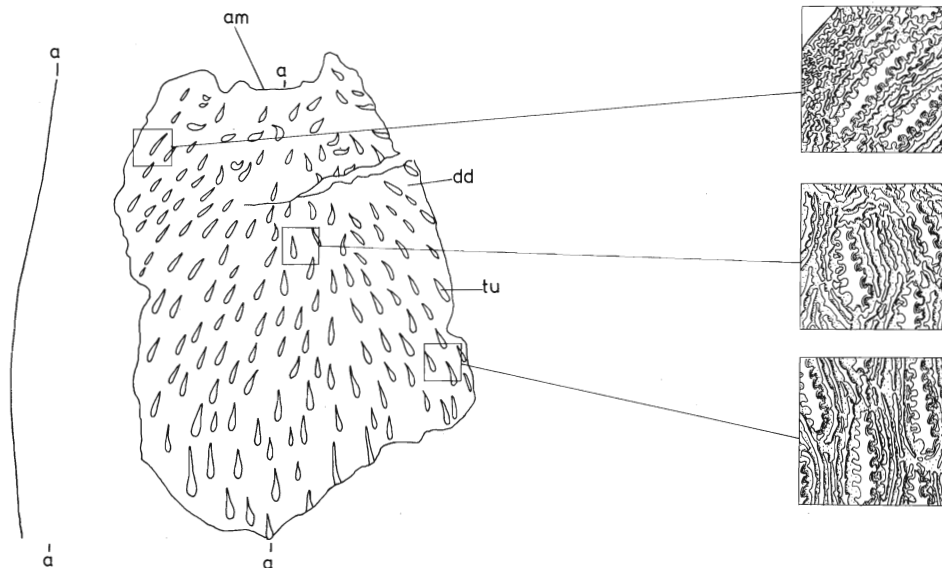

TEXT-FIG. 5. ?*Traquairaspis retusa* sp. nov., variation in ornamentation of dorsal shield (NMC 21422, holotype); plan view  $\times 1.875$ , detail  $\times 7.5$ . *a-a*, line of cross-section; *am*, anterior margin; *dd*, dorsal disc; *tu*, lachrymiform tubercle.

Lateral ornamentation of cyclomoriform units, passing anteriorly and laterally into broad, flat pustules. Posterior margin of ventral shield with bi-lobed, median process.

*Holotype*. NMC 21416, an incomplete ventral shield (Pl. 2, fig. 1; text-fig. 6).

*Other material*. NMC 21417, 21471, incomplete ventral shields.

*Locality*. GSC 69017.

*Description*. The holotype ventral shield (NMC 21416), which is incomplete both centrally and anteriorly, is 75 mm long and 45 mm wide. Its lateral margins are convex and its posterior margin terminates in a median bi-lobed process, formed by the convergence of the tubercular ornament. The shield is deeply vaulted both from front to back and from side to side. Laterally, ornamentation is of elevated, serrated tubercles, surrounded by narrower interstitial ridges with a concentric arrangement (text-fig. 6). The anterior and central areas of the disc have an ornament of large, broad, flat-topped tubercles with no interstitial ridges. There is a complete gradation between these two types of ornamentation. On the lateral margins of the shield, cyclomoriform units are centred on long (10–25 mm), narrow (0.35 mm) tubercles with branched lateral processes. The spaces between the tubercles are occupied by narrow (density ten per mm) ridges with short lateral processes; these interstitial ridges converge around the ends of the tubercles. Approximately 8 mm from the lateral margins of the shield, narrow tubercles are replaced by lachrymiform tubercles up to 4 mm long and 0.6 mm wide; these tubercles are narrower anteriorly than posteriorly, have short, anteriorly directed, lateral processes, and are surrounded by concentrically arranged interstitial ridges. Lachrymiform tubercles are replaced by

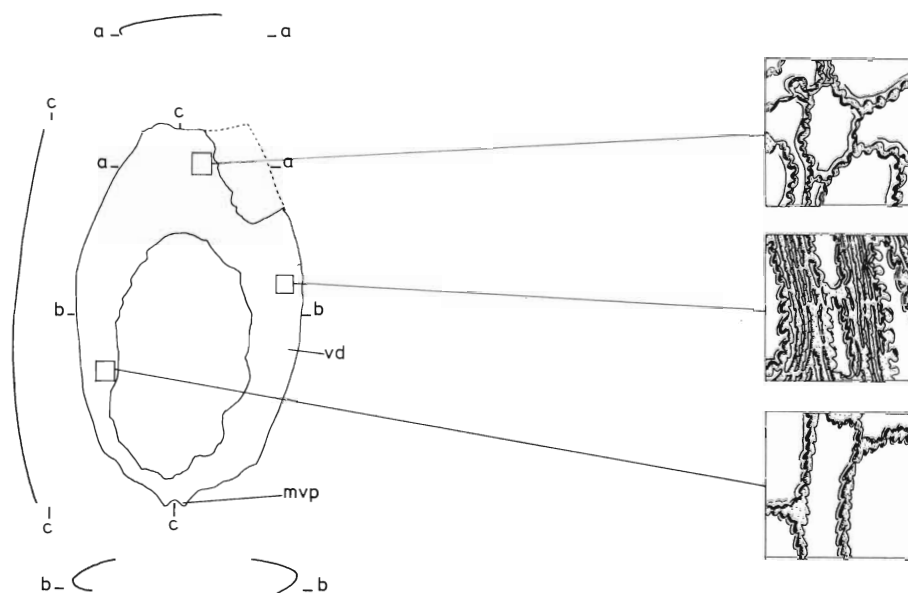

TEXT-FIG. 6. *?Traquairaspis pustulata* sp. nov., variation in ornamentation of ventral shield (NMC 21416, holotype); plan view  $\times 1.875$ , detail  $\times 7.5$ . *a-a*, *b-b*, *c-c*, lines of cross-section; *mvp*, median bilobed process; *vd*, ventral disc.

oval, flat-topped tubercles up to 4 mm long and 2 mm wide, 15 mm from the lateral margins of the disc. These are more closely placed than the lateral tubercles and have fewer interstitial ridges. The ornament of much of the anterior part of the shield and of that part of the central area which is preserved, is of oval and circular, flat-topped tubercles which are about 4 mm long and 3–4 mm wide. Between the oval tubercles are triangular and irregularly shaped tubercles of various sizes. Lateral line pores commonly notch the margins of the circular tubercles. The long axes of the median tubercles are longitudinally orientated, becoming fanned-out anteriorly; lateral tubercles are arranged parallel to the lateral margins of the disc. Convergence of the most median lachrymiform tubercles produces a bi-lobed median process on the posterior margin of the shield (Pl. 2, fig. 1).

*Remarks.* The shape of the disc and the form of the lateral ornamentation indicate the traquairaspid nature of this form. Although a smooth or ornamented ventral primordium is typical of other species, ventral coarsening of tubercles such as that

#### EXPLANATION OF PLATE 2

Fig. 1. *?Traquairaspis pustulata* sp. nov. Incomplete ventral shield (NMC 21416, holotype),  $\times 0.75$  (see text-fig. 6).

Fig. 2. *?Traquairaspis* cf. *T. pustulata* sp. nov. Incomplete ventral shield (NMC 21448),  $\times 1.75$ .

Fig. 3. *?Traquairaspis broadi* sp. nov. Incomplete ventral shield (NMC 21418, holotype),  $\times 1.75$  (see text-fig. 8).

Fig. 4. *?Traquairaspis* cf. *?T. pustulata* sp. nov. Incomplete ventral shield (NMC 21447),  $\times 1.75$ .

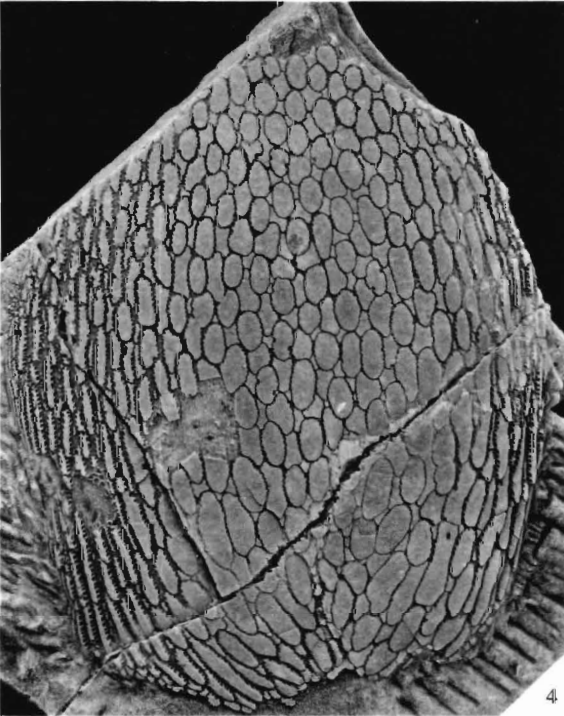

DINELEY and LOEFFLER, *Traquairaspis*



exhibited by *?T. pustulata* also occurs in *?T. guttata* and in *?T. broadi* from the same locality. *?T. pustulata* is distinguished from these species by its large size and by details of its ventral ornamentation.

*?Traquairaspis* cf. *?T. pustulata*

Plate 2, figs. 2, 4; text-fig. 7

*Material.* NMC 21447-21448, 21488, incomplete ventral shields (Pl. 2, figs. 2, 4).

*Localities.* (A) GSC 58497; (B) GSC 75853 (NMC 21448 only).

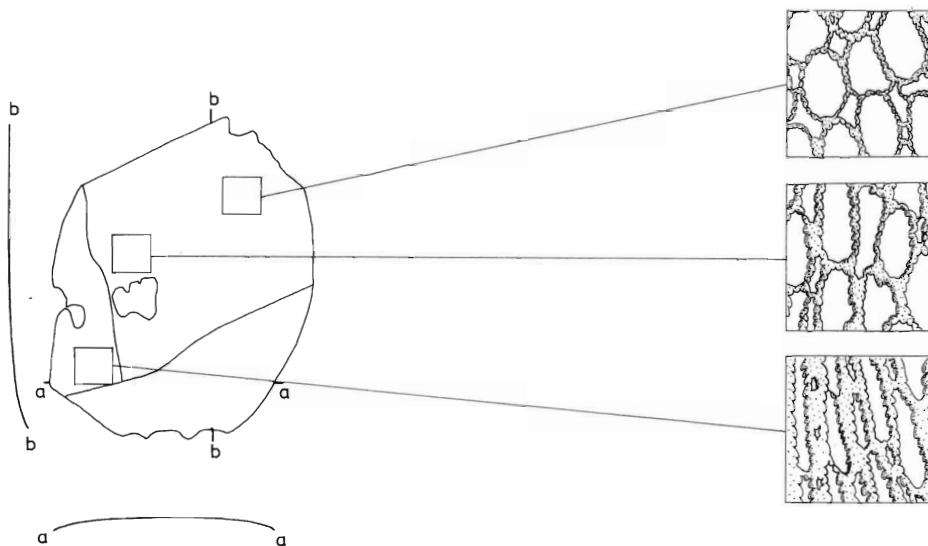

TEXT-FIG. 7. *?Traquairaspis* cf. *T. pustulata* sp. nov., variation in ornamentation of ventral shield (NMC 21447); plan view  $\times 0.75$ , detail  $\times 7.5$ . *a-a*, *b-b*, lines of cross-section.

*Description.* The two most complete shields (NMC 21447 and 21448) (Pl. 2, figs. 2, 4), which are oval in shape and only slightly vaulted, are over 60 mm long and 46 mm wide. The central ornament of circular, irregular, and oval tubercles (1.5–2.5 mm in diameter) passes gradationally into long (3–7 mm), narrow (0.5–1.0 mm) lachrymiform tubercles toward the convex lateral margins of the shield (text-fig. 7). Both types of tubercle have anteriorly directed, lateral processes, but those of the more lateral tubercles are longer and more prominent. Spaces between the more median tubercles are extremely narrow (0.25 mm) but, between lateral tubercles, may be up to 2 mm wide. Interstitial ridges are rare; when developed, they are short (1 mm) and randomly distributed in the wide spaces between the lateral tubercles. Lateral line pores notch the margins of some of the anterior, circular tubercles; the pores are commonly paired, and placed diametrically opposite one another on either side of a tubercle (Pl. 2, fig. 4).

*Remarks.* In its circular and irregular median tubercles and lachrymiform lateral tubercles, this ventral shield closely resembles that of *?T. pustulata*. In this material,

however, the numerous low interstitial ridges, which are arranged about the lateral tubercles of *?T. pustulata* are lacking. Since the presence of ornamentation of that type is one of the strongest reasons for including *?T. pustulata* in the Traquairaspididae, its absence makes it necessary to separate it from this form. For this reason, the specimens described above are referred to *?Traquairaspis* cf. *?T. pustulata*.

Denison (1963) described a shield fragment (his Heterostraci indet., Type D), with similar ornamentation, from the Beaver River area of south-eastern Yukon; Tarlo (1964) subsequently referred this material to a new species, *Tesseraspis denisoni*.

*?Traquairaspis broadi* sp. nov.

Plate 2, fig. 3; text-fig. 8

*Derivation of name.* After Dr. D. S. Broad.

*Diagnosis.* Large ventral shield (55 mm long  $\times$  45 mm wide), lacking a ventral primordium. Lateral ornamentation of cyclomoriform units with narrow interstitial ridges, grading medially into ornamentation with tubercles and interstitial ridges of almost equal width.

*Holotype.* NMC 21418, incomplete ventral shield (Pl. 2, fig. 3; text-fig. 8).

*Other material.* NMC 21419, ventral shield fragment.

*Locality.* GSC 69017.

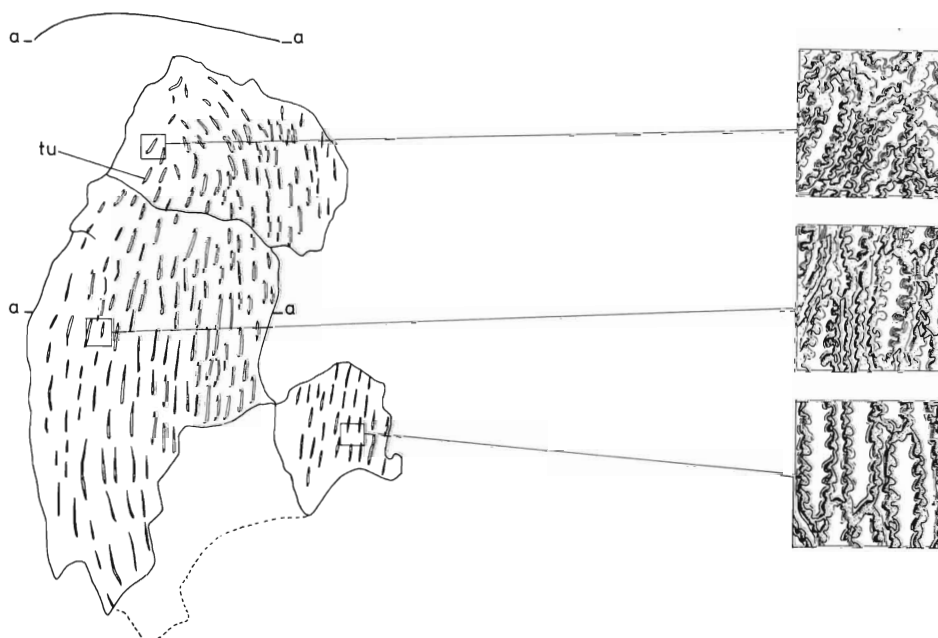

TEXT-FIG. 8. *?Traquairaspis broadi* sp. nov., variation in ornamentation of ventral shield (NMC 21418, holotype); plan view  $\times 1.125$ , detail  $\times 6$ . *a-a*, line of cross-section; *tu*, serrated lachrymiform tubercle.

*Description.* Although incomplete, the holotype (NMC 21418) indicates a ventral shield at least 55 mm long and 45 mm wide, with lateral margins which are concave anteriorly and convex posteriorly. Laterally, ornamentation is of cyclomoriform units, each of which is centred on a large, elevated, non-lachrymiform tubercle 3–7 mm long and 0.75 mm wide. These tubercles have U-shaped marginal indentations and are surrounded by low, twig-like ridges (density three per mm) with short lateral processes (text-fig. 8). At the front and centre of the shield, the ornament loses its cyclomoriform character and there is less difference in size between the tubercles and interstitial ridges. The tubercles in the central and anterior parts of the shield are of similar size to those of the lateral margin, but lack the U-shaped indentations, having anteriorly directed lateral processes (text-fig. 8). In this area of the shield, interstitial ridges are fewer in number than laterally; one or two ridges occupy the interspace between tubercles. Although slightly narrower (0.5–0.7 mm) and longer (up to 10 mm), the interstitial ridges resemble the tubercles in shape. The lateral cyclomoriform units are arranged parallel to the lateral margin but tend to converge anteriorly. The coarser, central ornamentation has a largely longitudinal arrangement, but fans out anteriorly (Pl. 2, fig. 3).

*Remarks.* The cyclomoriform ornamentation of serrated ridges and tubercles indicates traquiraspidid affinities. The lack of a distinct ventral primordium, the shape of the disc, and the broad medial ornamentation suggest that this is a ventral disc. ?*T. broadi* is distinguished from other species by its ventral ornamentation.

?*Traquiraspis lemniscata* sp. nov.

Plate 4, fig. 2; text-fig. 9

*Diagnosis.* Ventral shield of moderate size (50 mm × 30 mm), with medial ornament of broad (4 mm) ridges and tubercles passing laterally into narrower ridges (0.8 mm wide) and very narrow interstitial ridges.

*Holotype.* NMC 21436, incomplete and flattened ventral shield (Pl. 4, fig. 2; text-fig. 9).

*Type locality.* GSC 81050 (holotype only).

*Other material.* NMC 21437, incomplete, flattened ventral shield.

*Other localities.* GSC 75853 (NMC 21437 only).

*Description.* The holotype, which is 50 mm long and 30 mm wide, is an almost entire symmetrical plate of approximately oval shape. Its lateral margins are convex, its posterior and anterior margins are incomplete. Over the greater part (c. 85%) of the plate, ornamentation is of broad (up to 4 mm), long (up to 30 mm), flat-topped ridges with finely serrated margins which are arranged parallel to the length of the plate (Pl. 4, fig. 2). At front and rear, broad ridges are replaced by irregular and circular tubercles of similar width. The tubercles are commonly notched by pairs of lateral line pores occurring on diametrically opposite sides (text-fig. 9). Where ridges and tubercles are broad, the width of grooves which separate them is 0.2–0.4 mm. Laterally, broad ridges give way to narrower (0.6–0.8 mm) ridges with long, anteriorly directed processes. The wide (2 mm) interspaces adjacent to the narrow ridges are occupied by low, very narrow (0.05–0.1 mm), long (up to 15 mm)

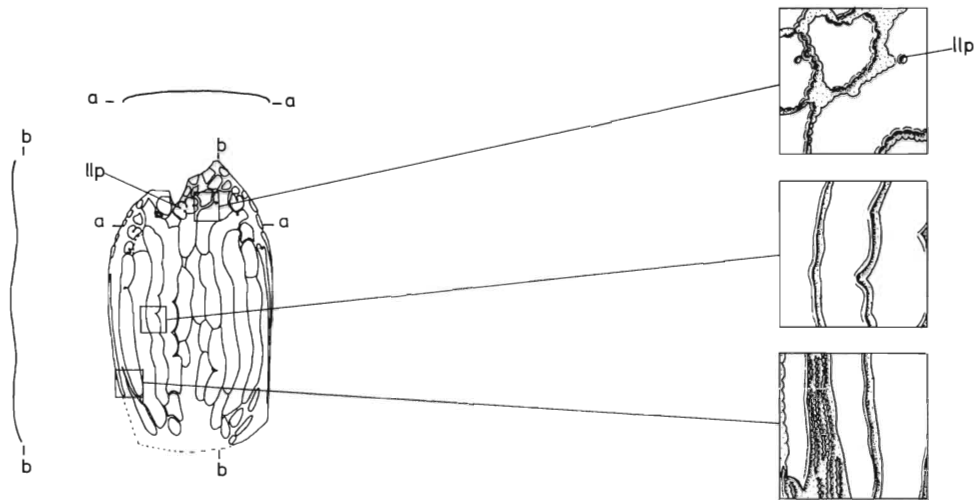

TEXT-FIG. 9. ?*Traquairaspis lemniscata* sp. nov., variation in ornamentation of ventral shield (NMC 21436, holotype); plan view  $\times 0.75$ , detail  $\times 3.75$ . *a-a*, *b-b*, lines of cross-section; *llp*, lateral line pore.

ridges with anteriorly directed processes; these interstitial ridges may be curved around the broader ridges.

*Remarks.* The elevated, serrated tubercles and low, interstitial ridges of this form indicate a member of the Traquairaspididae. Although ornamentation of this type, with long, broad medial ridges has not previously been described, it is not unexpected in view of the variety of ventral ornamentation in traquairaspidids from the Delorme Formation. With others from the Delorme Formation, this species shares the tendency for the ornamentation to be broader and flatter-topped toward the longitudinal mid-line of the ventral shield (see p. 43).

*?Traquairaspis mackenziensis* sp. nov.

Plate 3, figs. 1-4; text-figs. 10-14

*Diagnosis.* Moderate-sized (55 mm long  $\times$  30 mm wide) traquairaspidid with dorsal armour including a large plate which completely encloses the pineal, branchial, and orbital openings but apparently does not extend to cover rostrum. Dorsal ornamentation of laterally serrated, non-uniform ridges and tubercles of low relief; medial ornament of cyclomoriform units passes laterally into elongate tubercles and parallel interstitial ridges. Ventral shield ornamented by broad, flat-topped, laterally serrated ridges of uniform height medially passing laterally into variable narrow ridges without cyclomoriform arrangement. Dorsal and ventral shields oval, elongated, and depressed.

*Holotype.* NMC 19782, incomplete dorsal shield (Pl. 3, fig. 1; text-fig. 12).

*Paratypes.* NMC 19790 (Pl. 3, fig. 4; text-fig. 11), NMC 19791 (Pl. 3, fig. 3; text-fig. 10), incomplete dorsal shields; NMC 19801 (Pl. 3, fig. 2; text-fig. 14), incomplete ventral shield.

*Other material.* Seventeen dorsal shield fragments: NMC 19781, 19783–19789, 19792–19800. Twenty-five ventral shield fragments: NMC 19802–19809, 19810b, 19811–19817, 19861–19869.

*Locality.* GSC 69017.

*Description.* (1) *Dorsal shield:* The rostral area, anterior to the orbits, is not preserved in any of the dorsal shields, which are otherwise well preserved anteriorly; the transverse margin immediately anterior to the orbits is assumed to have been the anterior edge of the shield. In the holotype, the shield is at least 55 mm long and 30 mm wide, oval and only slightly convex; others are similar in shape and size. The orbits, which have a diameter of 2.0–2.5 mm, are lateral, but appear to have been dorsally directed.

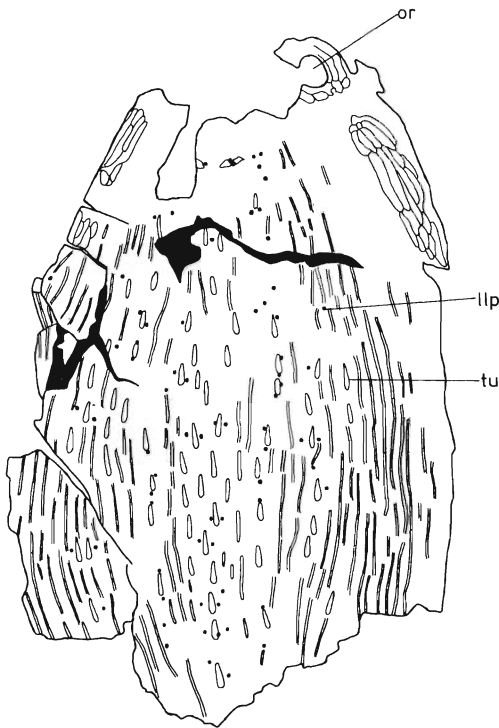

TEXT-FIG. 10. ?*Traquairaspis mackenziensis* sp. nov., relationship of lateral line pores to coarse elements of ornamentation of dorsal shield (NMC 19791, paratype);  $\times 1.875$ . *llp*, lateral line pore; *or*, orbit; *tu*, lachrymiform tubercle.

A pineal foramen, approximately 1 mm in diameter, lies close behind the interorbital line. Like the orbits, the single pair of branchial openings are completely enclosed; approximately 6–7 mm long and 1.5 mm wide, they are placed laterally within the anterior half of the dorsal shield. An inwardly directed lamina, approximately 2 mm wide, extends along the length of the lateral margins of the dorsal shield.

Ornamentation is of dentine ridges and tubercles with finely serrated margins. In front of an imaginary line joining the posterior margins of the branchial openings to a transverse row of post-pineal tubercles, the ornamentation contrasts with that behind. The anterior pattern is dominated by eight to ten broad (0.3–0.4 mm wide) ridges arranged concentrically about each orbit, four to five about the pineal foramen, and by the broad ridges and tubercles on the lateral margin of the shield, between the orbits and the branchial openings. The

remaining anterior ornament comprises low, narrow (0.2 mm) ridges and tubercles which are transverse anteriorly and arranged parallel to the margins of the shield laterally. Behind the post-pineal tubercles are ridges, some higher and wider than

#### EXPLANATION OF PLATE 3

Figs. 1–4. *Traquairaspis mackenziensis* sp. nov. 1, incomplete dorsal shield (NMC 19782, holotype),  $\times 2$  (see text-fig. 12). 2, incomplete ventral shield (NMC 19801, paratype),  $\times 2$  (see text-fig. 14). 3, incomplete dorsal shield, lateral view (NMC 19790, paratype),  $\times 2$  (see text-fig. 11). 4, incomplete dorsal shield (NMC 19791, paratype),  $\times 2$  (see text-fig. 10).



DINELEY and LOEFFLER, *Traquairaspis mackenziensis*

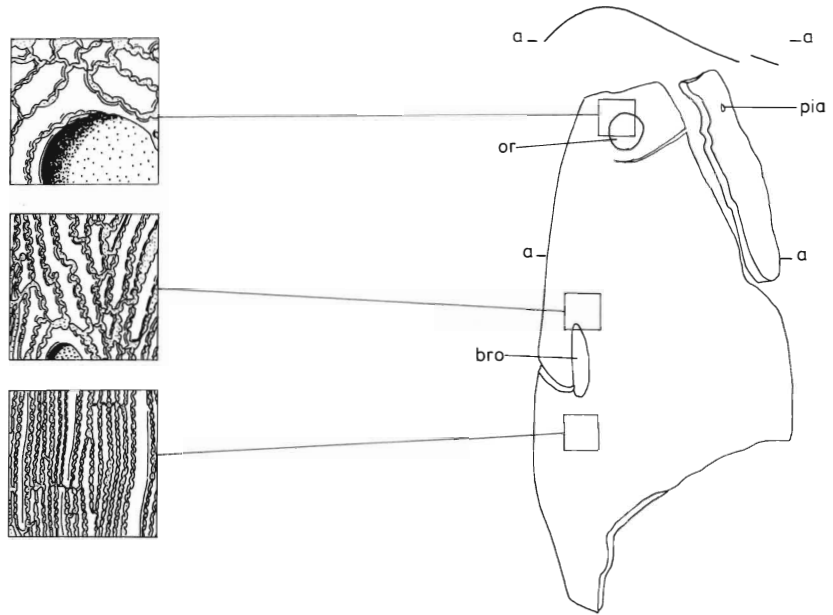

TEXT-FIG. 11. *Traquairaspis mackenziensis* sp. nov., variation in ornamentation on lateral margins of dorsal shield (NMC 19790, paratype); plan view  $\times 1.5$ , detail  $\times 6$ . *a-a*, line of cross-section; *bro*, branchial opening; *or*, orbit; *pia*, pineal macula.

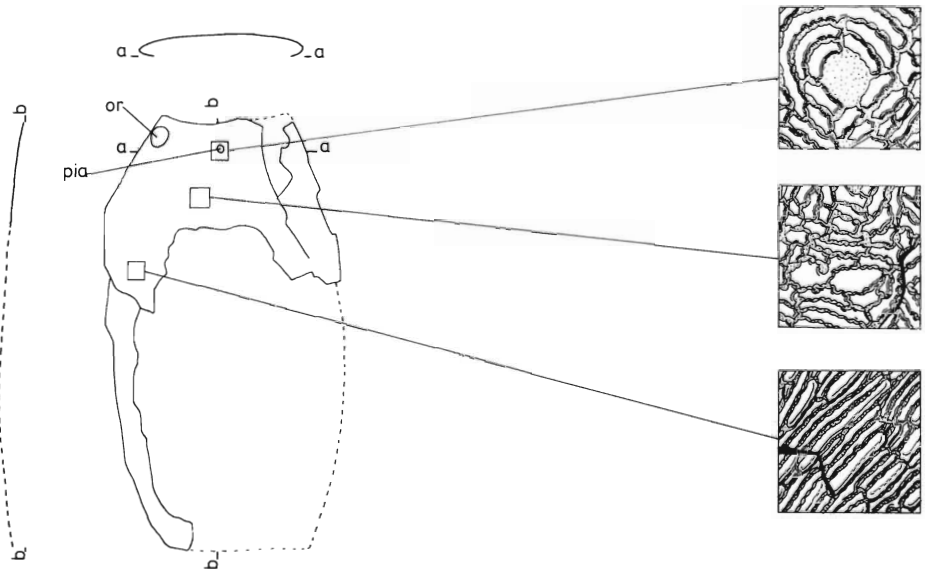

TEXT-FIG. 12. *Traquairaspis mackenziensis* sp. nov., variation in ornamentation on anterior part of dorsal shield (NMC 19782, holotype); plan view  $\times 1$ , detail  $\times 6$ . *a-a*, *b-b*, lines of cross-section; *or*, orbit; *pia*, pineal macula.

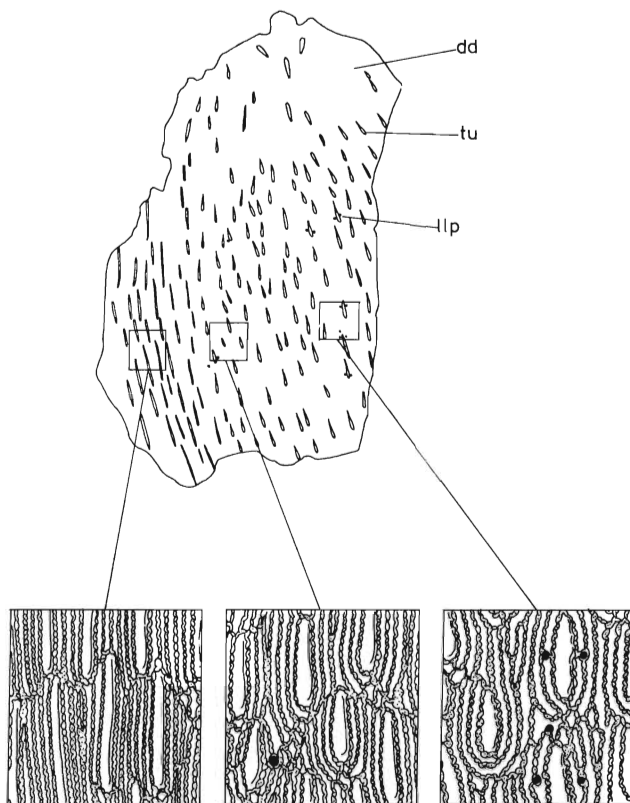

TEXT-FIG. 13. ?*Traquairaspis mackenziensis* sp. nov., variation in ornamentation across dorsal shield (NMC 19792); plan view  $\times 1.875$ , detail  $\times 7.5$ . *dd*, dorsal disc; *llp*, lateral line pore; *tu*, lachrymiform tubercle.

others, which are arranged almost parallel to the lateral margins of the shield. There is a gradation of ornamentation across the shield (text-fig. 13). Medially, ridges are arranged in cyclomoriform units, each of which comprises a central, lachrymiform tubercle 1–2 mm long, bordered laterally by narrow interstitial ridges with a density of five per mm. The interstitial ridges curve around the anterior and posterior margins of the lachrymiform tubercles and may be subdivided into short lengths or interrupted by conspicuous lateral line pores (text-fig. 13). Toward the sides of the shield, the cyclomoriform arrangement is gradually lost so that, close to the margin, the pattern consists of elevated, parallel sided ridges, 1–5 mm long, separated from one another by a variable number of interstitial ridges with a density of six per mm; both the low and the elevated ridges have finely serrated lateral margins. On the lateral margin of the shield and extending across the ventro-lateral lamina, coarse ridges are long (15–40 mm) and continuous (text-fig. 11); the finer long and parallel ridges have a density of seven per mm. Although the posterior margin of the dorsal shield is missing, alignment of cyclomoriform units (NMC 19791, text-fig. 10) suggests that a median dorsal crest may have been present.



(2) *Ventral shield*: The best-preserved ventral shield (NMC 19801, Pl. 3, fig. 2; text-fig. 14) is approximately 50 mm long and 26 mm wide, elliptical and slightly convex, tapering slightly more toward the anterior than the posterior; less complete shields are of comparable shape and size. The anterior margin of the shield is concave, with rounded antero-lateral corners, the shield being widest midway along its

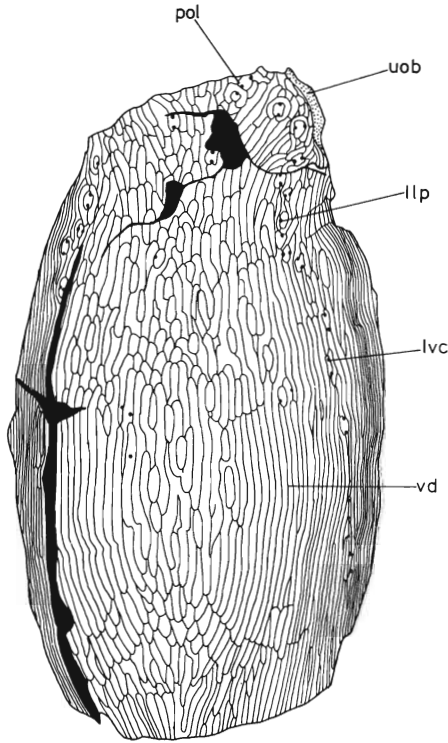

TEXT-FIG. 14. ?*Traquairaspis mackenziensis* sp. nov., relationship of lateral line pores to ornamentation of ventral shield (NMC 19801, paratype);  $\times 1.875$ . *llp*, lateral line pore; *lvc*, pore on line of lateral ventral canal; *pol*, pore on post-oral canal; *uob*, unornamented brim; *vd*, ventral disc.

length and tapering to a convex posterior margin. An unornamented brim 1.0–1.5 mm wide extends along the lateral margin, being preserved antero-laterally in NMC 19801 (text-fig. 14). Ornamentation is of dentine ridges and tubercles with fine lateral serrations. Medial ridges are wide (1.0–1.5 mm) and flat-topped, separated from one another by narrow grooves; these ridges are commonly branched or subdivided into oval tubercles anteriorly. Near the side of the shield, narrow (average five per mm) ridges are interposed between broader ridges as on the lateral margins of the dorsal shield. Ridges and tubercles tend to converge posteriorly and to diverge anteriorly on the ventral shield.

(3) *Lateral line system*: Lateral line canals are not visible and no attempt has been made to prepare them, but numerous sensory pores are present on both dorsal and ventral shields. On the dorsal shield, pores are commonly paired and associated with the lachrymiform tubercles. The scattered distribution of pores (text-fig. 10) does not show the form of the dorsal lateral line network. On the ventral shield, pores are also paired and are commonly associated with oval and circular tubercles, of which they notch the diametrically opposite margins. The alignment of ventral pores indicates the presence of lateral ventral and post-oral canals (text-fig. 14).

*Remarks.* ?*Traquairaspis mackenziensis* is one of a number of traquairaspidids in which the dorsal shield is formed of a single large plate enclosing the pineal, orbital,

#### EXPLANATION OF PLATE 4

Figs. 1, 3–5. Traquairaspididae indet. 1, Type 2, incomplete dorsal disc (NMC 21421),  $\times 2$  (see text-fig. 16). 3, Type 3, incomplete dorsal disc (NMC 21415),  $\times 2$  (see text-fig. 17). 4, Type 4, plate fragment (NMC 21405),  $\times 2$  (see text-fig. 18). 5, Type 1, ventral shield fragment (NMC 21420),  $\times 2$  (see text-fig. 15). Fig. 2. *Traquairaspis lemniscata* sp. nov. Incomplete ventral shield (NMC 21435m),  $\times 2$  (see text-fig. 9).

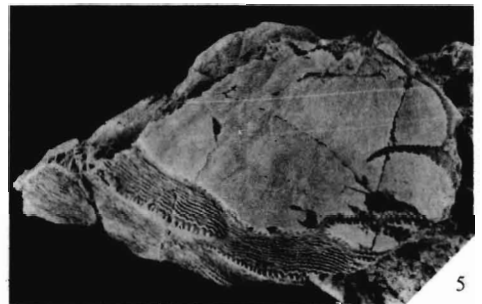
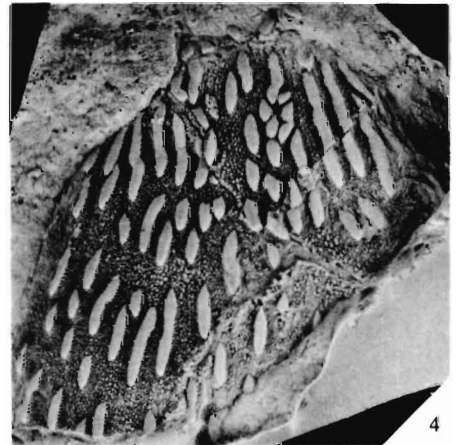
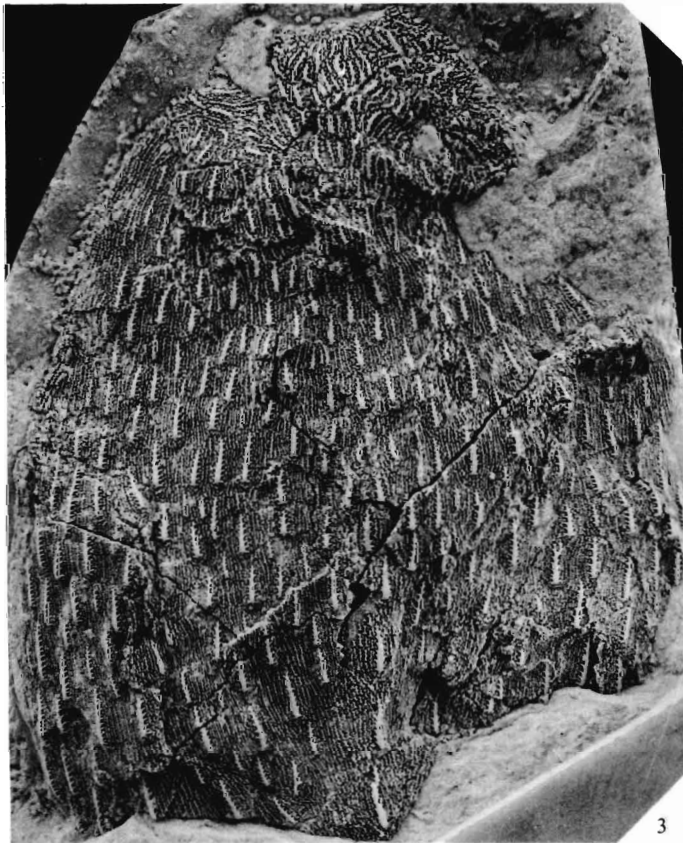

DINELEY and LOEFFLER, Traquairaspids

and branchial openings. It is not known whether the rostral region of this species was armoured and, if so, whether the rostral plate was separate from the rest of the dorsal shield. It is unique in the family Traquairaspididae in the low relief of the dorsal ornamentation and the simplicity of the ventral ornamentation, which excludes cyclomoriform units and consists of ridges which are broader medially than laterally. Both the dorsal and ventral shields are unusually depressed.

### Traquairaspididae indet., Type 1

Plate 4, fig. 5; text-fig. 15

*Material.* NMC 21420, ventral disc fragment.

*Locality.* GSC 81050.

*Description.* This specimen is part of the smooth ventral primordium and lateral brim. The lateral brim is 10 mm wide; it is sharply upturned several millimetres from the edge of the primordium, along a line marked by the central tubercles of two cyclomoriform units (Pl. 4, fig. 5). Each relatively large cyclomoriform unit is centred on a median tubercle 10 mm long and 1 mm wide. The interstitial ridges, which are concentrically arranged about the tubercles, have short, lateral processes and an average density of five ridges per mm. The irregular and indented margin of the primordium bears fine lateral serrations with anteriorly directed projections (text-fig. 15). Posteriorly, indentations of the lateral margin of the primordium almost isolate an oval, flat-topped tubercle. The tubercle, 6 mm long and 4 mm wide, is joined to the main primordium anteriorly and has finely serrated margins (Pl. 4, fig. 5). At the postero-lateral corner of the primordium, a similar but narrower

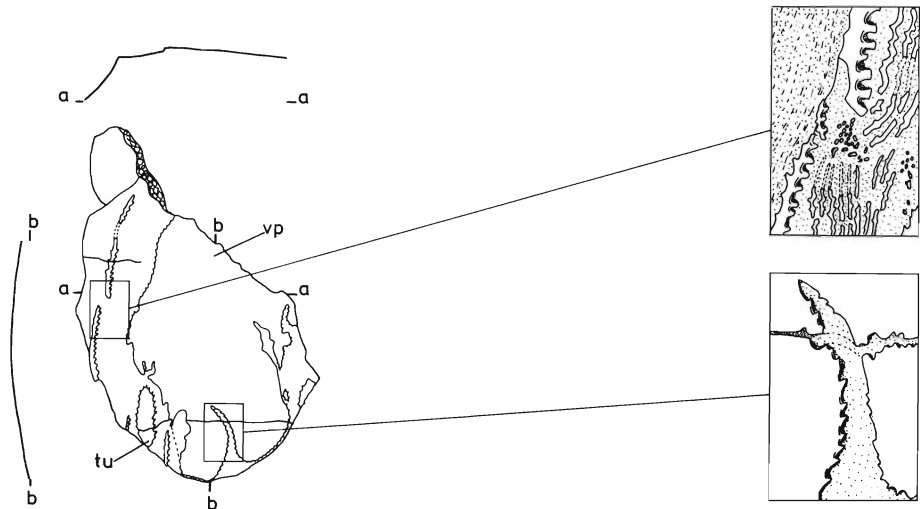

TEXT-FIG. 15. Traquairaspididae indet., Type 1, variation in ornamentation of ventral shield (NMC 21420); plan view  $\times 1.875$ , detail  $\times 7.5$ . *a-a*, *b-b*, lines of cross-section; *tu*, elevated tubercle; *vp*, ventral plate.

tubercle is isolated. These broad tubercles lack the surrounding narrow ridges which are typical of the cyclomoriform units of the lateral brim.

*Remarks.* Although the ornamented brim of this specimen is much wider than that of *T. angusta* Denison, the serrated and indented margin of the ventral primordium is common to both species. Ventral shields very close to *T. angusta* have recently been found on Somerset Island, and it is therefore necessary to distinguish this specimen from *T. angusta*.

### Traquairaspididae indet., Type 2

Plate 4, fig. 2; text-fig. 16

*Material.* NMC 21421, an incomplete dorsal disc.

*Locality.* GSC 69017.

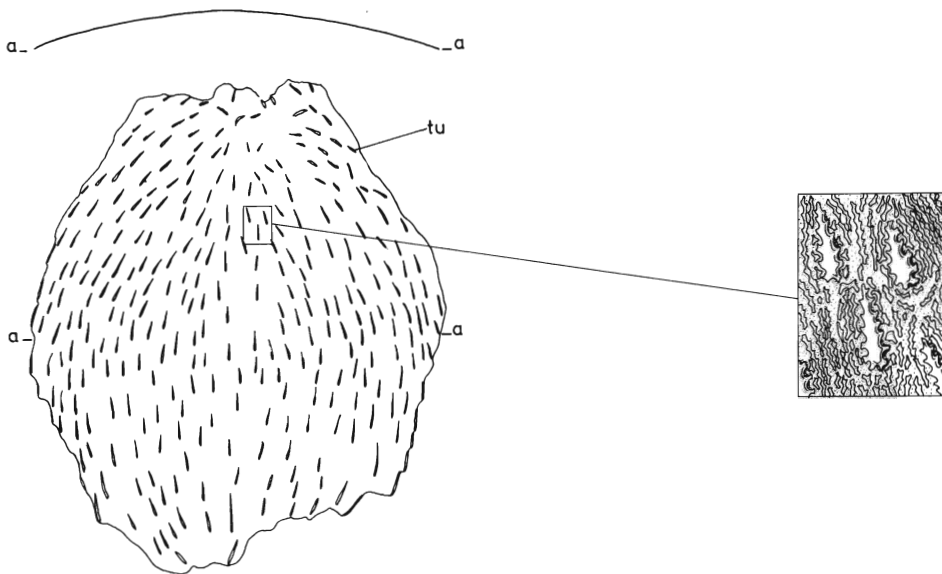

TEXT-FIG. 16. Traquairaspididae indet., Type 2, detail of ornamentation on dorsal shield (NMC 21421); plan view  $\times 1.875$ , detail  $\times 7.5$ , *a-a*, line of cross-section; *tu*, lachrymiform tubercle.

*Description.* The disc has a median length of 50 mm and a maximum width of 40 mm, but none of its margins is intact (Pl. 4, fig. 2). Ornament is entirely of small, cyclomoriform units, each with a large central elevated tubercle and narrow, concentrically arranged, interstitial ridges (text-fig. 16). The elevated tubercles are 1.5–4.0 mm long and 1 mm wide; the interstitial ridges have a density of eight to ten per mm. Both the ridges and tubercles have anteriorly directed, lateral processes; those of the tubercles are commonly bi-lobed. The arrangement of cyclomoriform units on the shield is almost elliptical, with greatest convergence posteriorly. On the hind part of the mid-line, the median tubercles of several cyclomoriform units form a low longitudinal crest; at the anterior end of the disc, several units are arranged transversely.

*Remarks.* Although the ornamentation of cyclomoriform units suggests reference of this form to the Traquairaspididae, it cannot be referred to a smaller taxonomic unit.

### Traquairaspididae indet., Type 3

Plate 4, fig. 3; text-fig. 17

*Material.* NMC 21415, an incomplete dorsal disc.

*Locality.* GSC 69017.

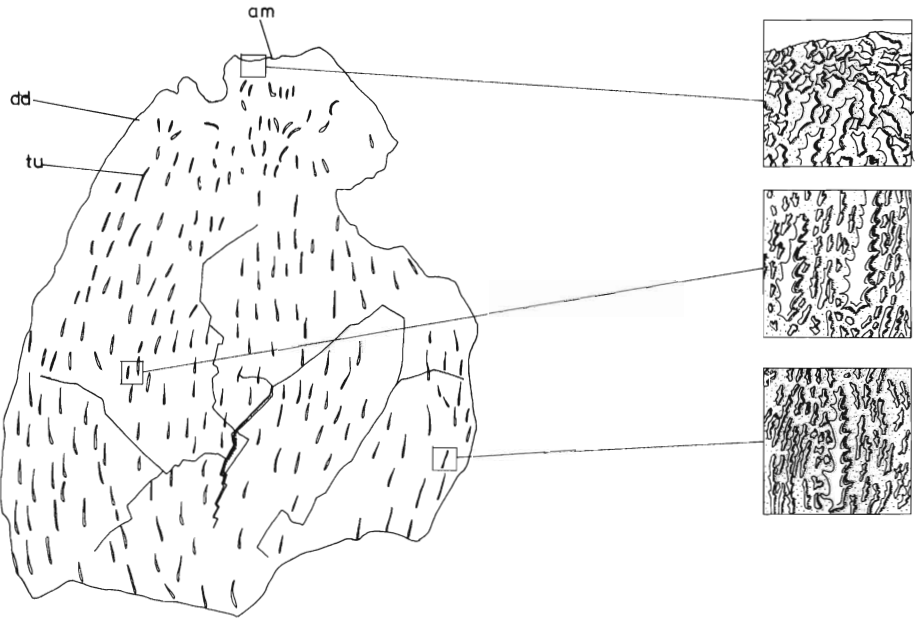

TEXT-FIG. 17. Traquairaspididae indet., Type 3, variation of ornamentation of dorsal shield (NMC 21415); plan view  $\times 1.125$ , detail  $\times 6$ . *am*, anterior margin; *dd*, dorsal disc; *tu*, elongated tubercle.

*Description.* This crushed and distorted dorsal disc is 55 mm long and 47 mm wide. The anterior margin appears to have been almost transverse, and the lateral margins convex; a posterior median crest is weakly developed (Pl. 4, fig. 3). Ornamentation is of cyclomoriform units, each consisting of a large lachrymiform tubercle surrounded by narrow ridges with a density of five per mm; both the tubercles and the interstitial ridges bear anteriorly directed, lateral processes. Cyclomoriform units have a slightly elliptical arrangement on the shield, converging anteriorly to a greater extent than posteriorly. Immediately behind the anterior margin of the shield, cyclomoriform units are replaced by broad (0.5 mm), short (2–3 mm) tubercles with short lateral processes. Between these tubercles are low stellate tubercles and low, narrow (0.2 mm) twig-like ridges, which lack a concentric arrangement (text-fig. 17). A low, median crest, formed by the alignment of several cyclomoriform units, occurs on the posterior part of the disc.

## Traquairaspididae indet., Type 4

Plate 4, fig. 4; text-fig. 18

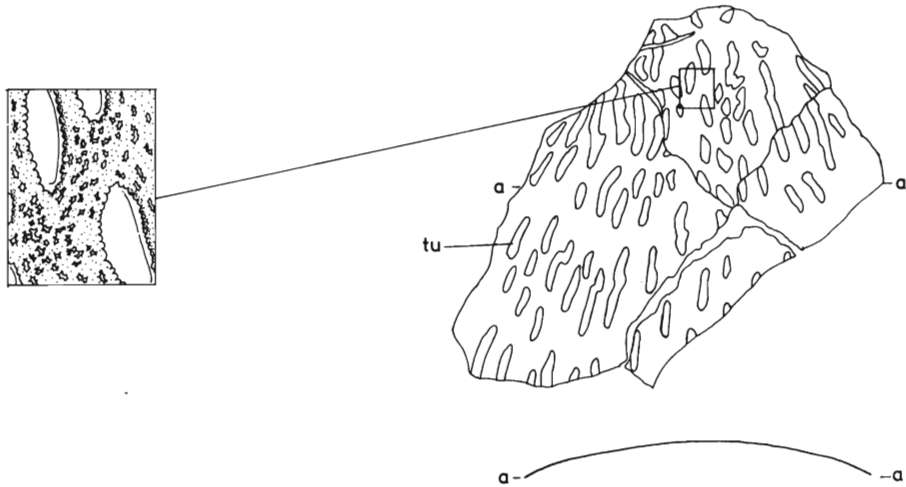
*Material.* NMC 21405-21406, shield fragments of indeterminate position.*Locality.* GSC 69017.

TEXT-FIG. 18. Traquairaspididae indet., Type 4, details of ornamentation (NMC 21405); plan view  $\times 1.875$ , detail  $\times 7.5$ . *a-a*, line of cross-section; *tu*, elevated and serrated ridge.

*Description.* Ornamentation of this form is particularly characteristic; it comprises two distinct elements: 1. Large (1.5–8.0 mm long  $\times$  0.8 mm wide), elongated, rounded-crested ridges, with fine lateral crenulations. These ridges are commonly kinked, unbranched, and are roughly aligned. 2. Small (0.4–1.0 mm long  $\times$  0.4 mm wide), commonly stellate tubercles and ridges. These may be concentrically arranged about the larger ridges but, more commonly, are randomly arranged in the interspaces.

*Remarks.* Known only from small fragments, ornamentation of this type has not previously been described in the Traquairaspididae, but the large, elevated, serrated ridges and the lower, narrower, interstitial ridges suggest that family.

## Traquairaspididae indet.

Specimens too poorly preserved to warrant full description are mentioned for stratigraphic purposes: they are not figured.

*A. Material.* NMC 13822. *Locality.* GS YG1 6F. *Description.* Small shield fragment with leaf-shaped tubercles, which have fine lateral serrations.

*B. Material.* NMC 13820–13821. *Locality.* CS YB10 9F. *Description.* Shield fragments with cyclomoriform units comprising poorly preserved tubercles and serrated interstitial ridges.

## GENERAL COMMENTS ON THE TRAQUAIRASPIDIDAE

*Morphology of the armour in the Traquairaspididae*

Claims for the close relationship of the Traquairaspididae and Pteraspididae on the basis of the similar configuration of their plates (Tarlo 1962a) must be examined carefully, since the similarity, based on early descriptions, may be more apparent than real.

White (1946) based his reconstruction of the *Traquairaspis* carapace on analogy with the Pteraspididae. He envisaged the dorsal shield as comprising paired orbital and branchio-cornual plates, unpaired rostral and pineal plates, and a dorsal disc. The dorsal disc and orbital plates commonly have broken, irregular margins; the pineal plate was known from only one specimen and the rostral plate was hypothetical. The symmetrical ventral shield was known from many well-preserved specimens; the lateral plates were placed on the ventral surface in White's reconstruction. In at least one species from the Arctic islands, the dorsal shield is made up of a single plate which formed the entire dorsal surface and enclosed branchial, orbital, and pineal openings (Broad 1971).

Three of the four new species from the Mackenzie Mountains in which dorsal shields are known (?*T. poolei*, ?*T. adunata*, and ?*T. mackenziensis*) have dorsal armour of the same type; in ?*T. poolei* only the branchial and dorsal disc regions are known, but in the other two species a single plate extends to enclose orbital, branchial, and pineal openings. The rostral region of ?*T. mackenziensis* is unknown; it may have been unarmoured.

The apparent variability in the number of dorsal plates in the Traquairaspididae can be interpreted in a number of ways: 1. The dorsal armour was formed from a single plate in primitive members of the family, but became subdivided in advanced members. 2. The dorsal armour comprised separate plates in primitive members of the family, but became fused in advanced members. 3. The dorsal armour comprised separate plates, which became fused only at maturity. 4. The dorsal armour was a single plate throughout the life of the organism, but the plate broke along lines of weakness, during post-mortem transportation and burial.

The fourth hypothesis can be rejected, at least for certain species; ?*Traquairaspis retusa*, Traquairaspididae Type 3 (this work), and others from the Arctic islands, all have distinct anterior borders to the dorsal disc. The third hypothesis can be rejected on the basis of material from the Arctic islands; fifty dorsal shields varied from 42 to 76 mm long and from 26 to 53 mm wide, but only one large disarticulated disc was found. It is only possible to determine which of the first two hypotheses may be valid by examination of an undescribed dorsal shield from the Wenlockian of Cornwallis Island (Broad 1971). Broad (1968, 1971) listed the latter specimen as a species known originally from the Peel Sound Formation. It may be akin to the Peel Sound material in having a single dorsal plate. A large traquairaspidid with a dorsal shield comprising a single plate was recently collected from transitional beds between the Allen Bay and Read Bay Formations of Somerset Island. Strata occupying a similar position on adjacent Prince of Wales Island have been dated as Late Wenlockian or Early Ludlovian (Dixon *et al.* 1972), so it is probable that the undivided dorsal carapace was characteristic of the earliest members of the family.

Little is known of the squamation of the Traquairaspididae; isolated scales (White 1946; Dineley 1964), which are all rather small and symmetrical, resemble those of the Pteraspididae, but have characteristic ornamentation.

#### *Growth in the Traquairaspididae*

The interpretations of growth put forward hitherto (Stensiö 1958, 1964; Tarlo 1960, 1962a; Halstead 1973) have involved application of the 'lepidomorial theory'. Broad (1971) recognized four distinct types of ornamentation in this family: 1. Synchronomorial ornament. 2. Ornament of tesserae. 3. Unornamented ventral primordium. 4. Ornament of cyclomorial units and rhombic areas. He considered each to involve a particular type of growth. This would imply that forms that appear to have been closely related must have grown in different ways.

Denison (1964) has shown that the ridge pattern of the cythaspidid *Tolypelepis* can be viewed in a number of different ways, and that the correct interpretation can only be determined by the histological study of growth stages. This must be true also of the Traquairaspididae, but juvenile forms have not yet been recognized. Denison's conclusion that the superficial ridges and grooves in the carapace of the Pteraspididae 'can only reflect soft structures that formed and grew in the skin prior to mineralisation of the disc' (1973, p. 3) is probably true for all Heterostraci.

As Broad (1971) recognized, three different types of ventral shield exist: 1. Unornamented ventral primordium with adjacent tesserae. 2. Ornamented ventral primordium with adjacent tesserae. 3. Entirely ornamented ventral shields.

The ventral shields of traquairaspidids from the District of Mackenzie differ fundamentally from those previously described. In only one specimen, Traquairaspididae indet., Type 1, is there a true, smooth, ventral area which differs from that of established species in having an irregular margin and in partly incorporating large, leaf-shaped tubercles. Other forms from the District of Mackenzie have a variety of ventral ornamentation, but all are characterized by progressive broadening and flattening of the ornament toward the longitudinal mid-line of the shield. This coarsening of the ornamentation is achieved in as many different ways as there are ventral shields. In ?*Traquairaspis lemniscata*, the long, narrow lateral tubercles pass medially into broad, flat ridges; interstitial ridges are present laterally, but are absent medially. In ?*T. guttata*, short, narrow, lateral tubercles pass medially into broad, flat, leaf-like tubercles; interstitial ridges are present medially and laterally, maintaining uniform width across the shield. In ?*T. broadi*, the elevated tubercles maintain a constant width across the shield; the interstitial ridges broaden toward the centre of the shield, where they achieve similar dimensions to the tubercles. In ?*T. pustulata*, both the lateral tubercles and the interstitial ridges broaden toward the mid-line of the shield; the tubercles grade medially into oval and circular, flat-topped pustules and the interstitial ridges are replaced by irregular tubercles with concave margins. In ?*T. mackenziensis*, the lateral ornamentation of the ventral shield is of closely spaced, laterally serrated ridges of non-uniform height: these grade into broad, flat-topped ridges and circular flat pustules toward the mid-line.

In terms of Denison's (1973) hypothesis, the smooth ventral ornamentation may reflect specialization of the soft tissue; Broad (1971) considered that it was the result of abrasion of the hard tissue. Neither hypothesis can be immediately rejected.



While there is no direct evidence of abrasion of the ventral surface of the shield, abrasion may have kept pace with the healing of the superficial layer or perhaps had its greatest effect upon the soft tissues prior to calcification.

The ornamentation of traquairaspidid type 1, with broad leaf-shaped tubercles grading medially into a true ventral primordium, suggests that the variety of ventral ornamentation in the family is the result of variation on a single theme.

#### *Phylogeny of the Traquairaspididae*

It is probable that the Cyathaspididae and the Traquairaspididae were both derived from an ancestor with a shield of scale-like, cyclomoriform units. The Traquairaspididae perhaps eventually gave rise to the Pteraspididae; they also produced a number of side lines, among them forms with complex lateral line systems, dorsal spines, and a variety of ornamentation. There is no reason to suppose, as did Broad (1971), that the presence of an anastomosing lateral line system in one group of traquairaspidids necessarily implies a relationship with the Irregularaspidinae. However, an anastomosing lateral line system may have been independently evolved in the Cyathaspidinae and the Irregularaspidinae (p. 109) and it could equally well have evolved independently in the Traquairaspididae. White (1946) observed that the lateral line system of *Traquairaspis* was very variable, irregular, and commonly asymmetrical. It is likely, therefore, that the path of the lateral line system was not stable in evolutionary terms, and this character should be considered with care in discussion of evolutionary relationships.

#### *Biostratigraphic significance of the Traquairaspididae*

White (1950a) attached great importance to the Traquairaspididae by drawing the Downtonian-Dittonian boundary in the Anglo-Welsh borders where *Traquairaspis* was replaced by *Protopteraspis leathensis* (White), and by basing the two uppermost zones of the Downtonian on the stratigraphic ranges of *T. pococki* and *T. symondsi*. Study of the faunas above and below the main 'Psammosteus' Limestone (Dineley and Gossage 1959; Ball and Dineley 1961) has revealed that, despite some overlap of their stratigraphic ranges, *Traquairaspis* is only common below the main limestone and *T. pococki* lies almost exclusively below *T. symondsi*. Allen and Tarlo (1963) proposed that the Downtonian-Dittonian boundary should be revised to coincide with the change from estuarine to fluvial conditions at the base of their 'Psammosteus' Limestones Group; this facies boundary was marked by a major faunal break, followed by the incoming of *Traquairaspis*. It is now also widely viewed (see p. 199) as a close approximation to the base of the zone of *Monograptus uniformis*, the (new) Siluro-Devonian boundary (McLaren 1973). Discoveries of *Traquairaspis* well below the 'Psammosteus' Limestones of the Anglo-Welsh borders, and of traquairaspidids in the Wenlockian of Arctic Canada, render the first appearance of *Traquairaspis* useless for the definition of the Siluro-Devonian boundary or as a guide fossil to the Late Downtonian. The known range of *Traquairaspis* now calls for a re-examination of correlations made on the basis of that genus alone (see p. 199).

The presence of *T. symondsi* in the succession of vertebrate faunas in North-west Europe and Nova Scotia (Dineley 1964, 1967), suggests that close correlation with the Anglo-Welsh succession is possible. Fragmentary 'traquairaspidid' material

from the Beyrichienkalk erratics of the Berlin area has received several names (see Ørvig 1961) but was regarded by Gross (1961) as insufficiently characterized to be regarded as anything other than *Traquairaspis* sp. indet. Similarity of the thelodont faunas from these erratics (Turner 1973) supports correlation with the *Traquairaspis* zones of the Anglo-Welsh succession. Indeterminate traquairaspidid fragments are present in the lower part of the Fraenkelryggen Formation of Vestspitsbergen, being broadly replaced by pteraspidids in the *primaeva* Beds (Ørvig 1961); this succession of faunas also correlates with the Anglo-Welsh Late Downtonian (Dineley 1967).

Traquairaspidids is an assemblage of ostracoderms in the Til'ze Suite of Lithuania (Karatajute-Talimaa 1962) suggest a late Downtonian or earliest Dittonian age; the presence of *Belgicaspis crouchi* in the overlying Stoniskyai Suite (Obruchev and Karatajute-Talimaa 1967) confirms this correlation. The *Traquairaspis*, in association with a typically Dittonian pteraspidid fauna reported from the Chortkov Horizon of Podolia (Obruchev and Karatajute-Talimaa 1967), is probably a misidentification of *Weigeltaspis*. *Weigeltaspis*, *Lepidaspis* gen. nov., *Lophosteus*, and others may readily be confused with *Traquairaspis* in fragmentary material.

Although the fish band at Cowie Harbour, Scotland, contains a cephalaspidid which suggests a basal Downtonian age (Westoll in discussion, in White 1946), the presence of *T. campbelli* led White (1946) to support correlation with the *Traquairaspis* zones of the Anglo-Welsh area. In view of the extended range of the Traquairaspididae, it is probable that this occurrence is basal Downtonian or older.

With the exception of the Wenlockian instance, reliably dated with associated graptolites (Thorsteinsson, *in lit.* in Broad 1971, pp. 123–124), all of the Canadian traquairaspidids Broad (1971) examined were from the Peel Sound Formation of Somerset and Prince of Wales Islands. Although the vertebrate fauna was suggestive of a Late Downtonian or Early Dittonian age, the invertebrate fauna of the same strata indicated the Silurian (Broad 1971; Broad and Dineley 1973).

Denison's (1964) datings of the ostracoderm faunas of the Beaver River and Muncho Lake areas may now be suspect; both were based entirely on the presence of *Traquairaspis*.

#### *Distribution of the Traquairaspididae*

It is apparent that the Traquairaspididae were present in Arctic Canada from the Wenlockian until at least the Pridolian. From the variety of species which occur in that area (Broad 1971), it appears that the family underwent much evolutionary diversification during this time. Although a representative was present in Scotland in perhaps the Early Downtonian, the Traquairaspididae did not become widespread in Europe until the Late Downtonian (*sensu* White 1950*a*). Within Europe, the stratigraphical range of the family is short; with the exception of a dubious occurrence, it had disappeared by the time the Pteraspididae were established in the Early Dittonian. The Traquairaspididae probably evolved and diversified largely within the tropical shelf seas of the North American continent. Only when the 'proto-Atlantic' ocean had narrowed sufficiently, were members of the family able to migrate to the European continent (see p. 201 for detailed discussion). While *Traquairaspis* does occur in Scotland in the Early Downtonian, that part of Britain is regarded as having been part

of the Silurian North American continent. Thus, it is not surprising that Broad (1971) has been able to demonstrate that *T. campbelli* has closer affinities with the Canadian traquairaspidids than with the two species from the Anglo-Welsh borders.

#### FAMILY CORVASPIDIDAE DINELEY, 1953

*Diagnosis.* Moderate-sized Heterostraci with armour completely enclosing orbits but not enclosing branchial openings. Ornamentation of short, smooth, closely spaced dentine ridges, grouped into units by a network of grooves. Within each unit, ridges are commonly parallel, but locally they may have a cyclomoriform or a scale-like arrangement. Posterior part of body with covering of small rhomboidal scales.

*Genera.* *Corvaspis* Woodward 1934.

#### Genus CORVASPIS Woodward, 1934

*Synonymy.* 1927 New Palaeaspid; Jaekel. 1934 *Corvaspis* new genus; Woodward. 1944 *Corvaspis* Woodward; Stensiö. 1953 *Corvaspis* Woodward; Dineley. 1958 *Corveaspis* (in error); Stensiö. 1960 *Corvaspis* Woodward; Tarlo. 1964 *Corvaspis* Woodward; Stensiö. 1964 *Corvaspis* Woodward; Tarlo. 1965 *Corvaspis* Woodward; Dineley. 1973 *Corvaspis* Woodward; Halstead.

*Diagnosis.* As for family (only genus so far described).

*Type species.* *Corvaspis kingi* Woodward, 1934.

#### *Corvaspis* sp. indet.

Plate 5, figs. 1, 2; text-figs. 19, 20

*Material.* NMC 19951 (Pl. 5, fig. 1; text-fig. 19), 19952, 19954, ventral shield fragments; NMC 19957 (Pl. 5, fig. 2; text-fig. 20), posterior and postero-lateral margin of median plate; NMC 19953, 19955, indeterminate fragments.

*Locality.* GSC 69017.

*Description.* Two of the three ventral shields (NMC 19951–19952, 19954) are well preserved anteriorly. The ventral shield is narrowest close behind the anterior margin, widening gradually to the posterior end and so producing concave lateral margins. The antero-lateral corner of the shield is deeply notched, and the otherwise transverse anterior margin has a single median notch and two pairs of lateral notches (Pl. 5, fig. 1). The complete ventral shield is estimated to have been over 40 mm long and to have had an anterior width of 30 mm, which increased posteriorly to over 60 mm.

Ornamentation is of short, closely spaced, flat-topped dentine ridges 0.2–0.3 mm wide and up to 1.5 mm long. These are grouped into units, approximately 1 mm wide and 2 mm long, which are separated from one another by a network of grooves

---

#### EXPLANATION OF PLATE 5

Figs. 1, 2. *Corvaspis* sp. indet. 1, incomplete ventral shield (NMC 19951),  $\times 3$  (see text-fig. 19). 2, plate fragment (NMC 19957),  $\times 3$  (see text-fig. 20).

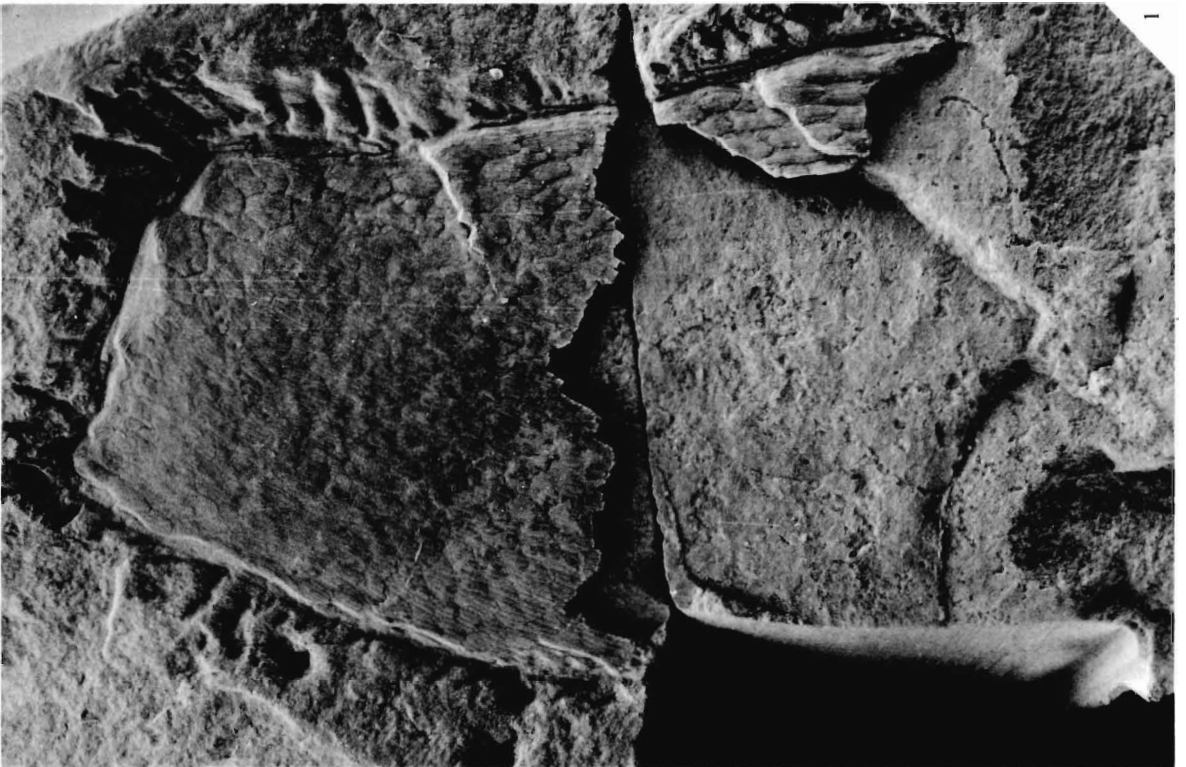
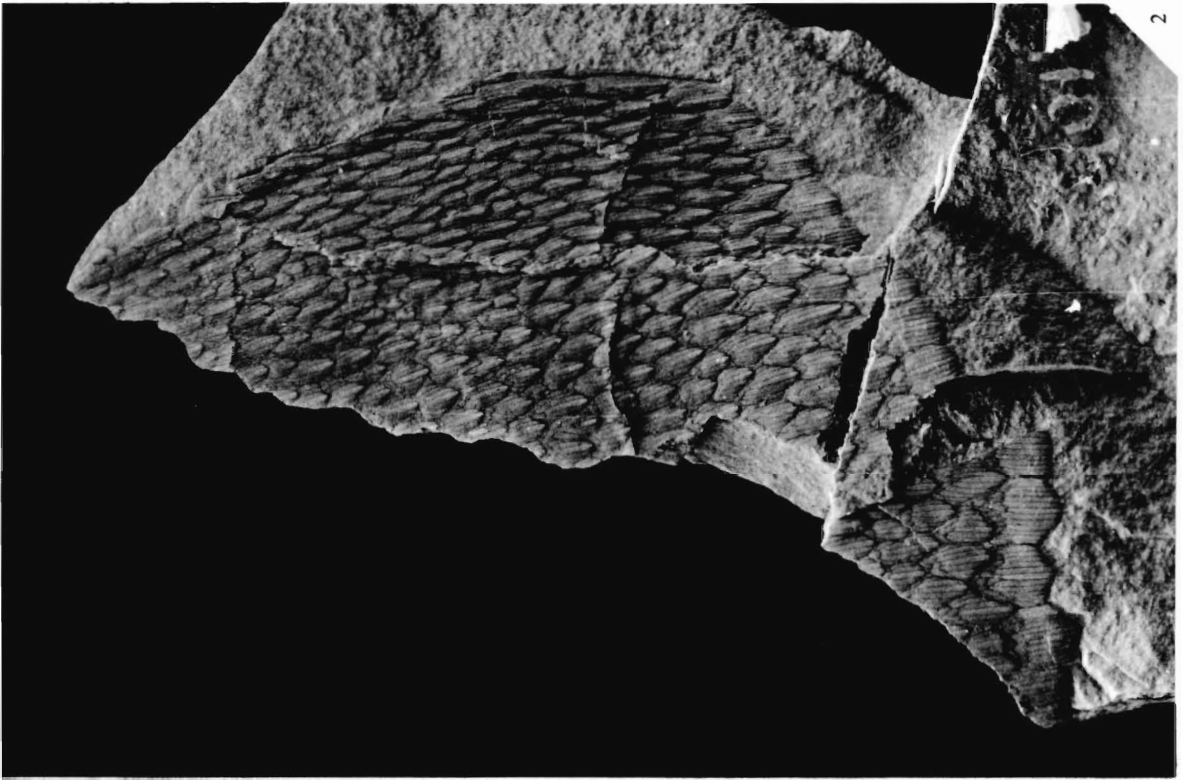

DINELEY and LOEFFLER, *Corvaspis* sp. indet.

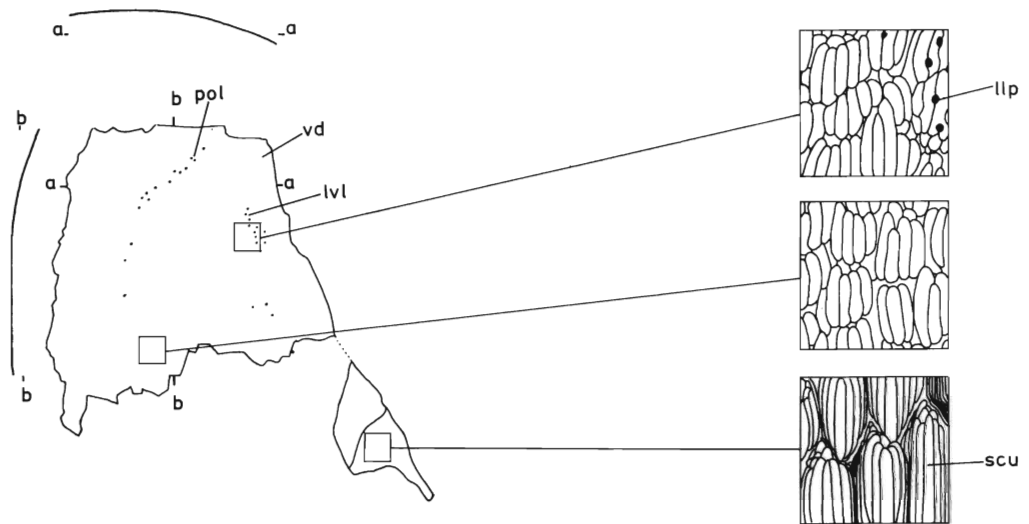

TEXT-FIG. 19. *Corvaspis* sp. indet., variation in ornamentation of ventral shield and distribution of lateral line pores (NMC 19951); plan view  $\times 1.125$ , detail  $\times 6$ . *a-a*, *b-b*, lines of cross-section; *lvl*, lateral ventral line; *pol*, post-oral line; *scu*, scale unit; *vd*, ventral disc.

(text-figs. 19, 20). Each unit commonly comprises several relatively long ridges, but may include shorter ridges and tubercles either anteriorly or posteriorly. Locally, some of the ridges are deeply indented by, or recurved around, lateral line pores (text-fig. 19).

Over the greater part of the shield, ridges are grouped into simple units of parallel or weakly cyclomoriform ridges with a longitudinal arrangement; anteriorly, there

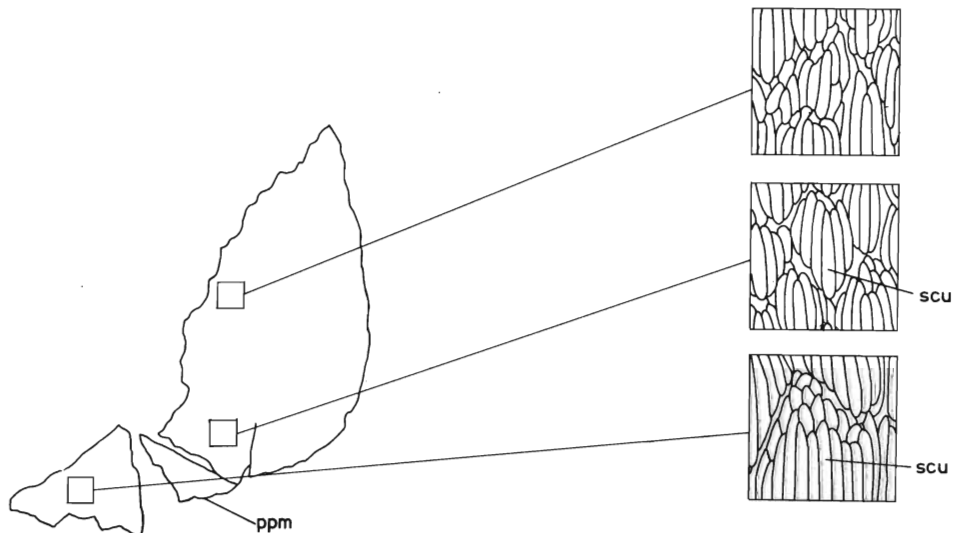

TEXT-FIG. 20. *Corvaspis* sp. indet., variation in ornamentation on posterior part of shield (NMC 19957); plan view  $\times 1.125$ , detail  $\times 6$ . *ppm*, posterior margin; *scu*, scale unit.

is a slight tendency to irregularity and a fan-like pattern of ridges (Pl. 5, fig. 1). Toward the postero-lateral extremity of NMC 19951, units take on an imbricated, scale-like appearance (Pl. 5, fig. 2). Each of these units is long (2–3 mm) and narrow (up to 1 mm) and has long ridges arranged behind small tubercles (text-fig. 20); the long ridges are not of uniform height, the median being higher and wider than the lateral ridges. In NMC 19957 (Pl. 5, fig. 2), all of the units are imbricated and scale-like; they increase in size posteriorly, those forming the posterior margin of the plate being up to 4 mm wide and 5 mm long (text-fig. 20). The anterior and antero-lateral margins of the ventral shield have a border of narrow (less than 0.1 mm) ridges arranged parallel to the shield margin. Lateral line pores indicate in NMC 19951 a post-oral canal, which continues posteriorly as a median ventral canal; there also appears to be a lateral ventral canal (text-fig. 19).

*Remarks.* Details of ornamentation distinguish this form from the European species of *Corvaspis*, all of which have dentine ridges 0.5 mm wide. The narrow (0.2–0.3 mm) dentine ridges of the specimens from the Delorme Formation are more closely comparable with those of material from Somerset Island (Loeffler and Dineley 1976). Ventral shields have not previously been described in *Corvaspis*; the median plates of *C. kingi* (Dineley 1953; Tarlo 1960) are irregular in shape and have coarse marginal tuberculation. No isolated tesserae have been found.

#### GENERAL COMMENTS ON THE CORVASPIDIDAE

##### *Morphology of the armour in the Corvaspididae*

The marginal tuberculation and spongy tissue of the irregular median plates and tesserae of *Corvaspis kingi* and *C. graticulata* suggest that the armour of these two species included a variable number of irregular plates. An analogous situation occurs in the Traquairaspididae, where some members of the family have a single dorsal shield and others have seven or nine minor dorsal plates. The minor dorsal plates in the Traquairaspididae, however, appear to be more constant in shape and number than the plates of *C. kingi* and *C. graticulata*.

In *C. arctica* (Loeffler and Dineley 1976) the dorsal armour formed a long, narrow shield, which enclosed the orbits but probably did not enclose the branchial openings. In over-all shape it is like some of the larger cyathaspidids, but is distinguished by its superficial ornamentation and its enclosed orbits. Unfortunately, the material is too friable for sectioning, which would establish the extent of histological similarity with the Cyathaspididae.

It appears that the earliest of the Traquairaspididae were forms with a single dorsal shield (p. 42); this may also have been true of the Corvaspididae. *Corvaspis* from the early Downtonian of Somerset Island has a unified dorsal shield, but *C. kingi* and *C. graticulata*, from the late Downtonian and Dittonian, have irregular plates and tesserae. The *Corvaspis* from the Wenlockian or Ludlovian of Prince of Wales Island (Turner and Dixon 1971) may ultimately indicate whether a continuous shield appeared earlier than median plates and tesserae in the Corvaspididae.

### *Growth in the Corvaspididae*

Tarlo described *Corvaspis* as having plates which appeared to be formed of numerous polygonal units fused together, but with each unit formed 'synchronomorially, in contrast to the cyclomorior formation in *Tolypelepis*' (1960, p. 223). Specimens of *Corvaspis* in which division into units was incomplete were, he thought, produced by the fusion of units prior to calcification. Regarding *Corvaspis* as a drepanaspid-like form with the main plates separated by fields of tesserae, Tarlo (1964) recognized various types of 'fused tesserae' within the main plates. Posterior units with longitudinal central ridges and peripheral tuberculation were described as synchronomorial tesserae with an outer cyclomorior zone, and interpreted as having formed before growth of the animal had ceased. The large plates with marginal tuberculation were interpreted similarly, their growth supposedly having been completed by the addition of a border of tubercles. Simple units of parallel ridges were interpreted as having formed synchronomorially.

Growth of the superficial units or of the plates of *Corvaspis* has yet to be demonstrated; the descriptions of growth by Stensiö (1958, 1964) and Tarlo (1960, 1962a, 1964, 1965) are based on interpretation of the pattern of dentine ridges. In criticizing similar views of the growth of *Tolypelepis*, Denison (1964) put forward several hypotheses which could equally well be applied to *Corvaspis*: 1. The apparent tesserae all formed early in life and grew, fusing at maturity. 2. The subdivision of the shield was restricted to the superficial layer and, although the superficial units may have grown, deeper layers did not develop until maturity. 3. There was no growth of the dorsal shield, all of which formed at maturity; the tesserae and scale-like units are relics of an earlier evolutionary stage. Without knowledge of growth stages it is not possible to find which alternative was most closely approached in *Corvaspis*.

The more posterior superficial units of the shield of *Corvaspis* from Somerset Island are identical to the isolated rhomboidal body scales. There is a complete gradation anteriorly, from scale-like units through synchronomoriform units to cyclomorioriform units. This suggests that, if the superficial subdivisions of the shield are relics of an earlier evolutionary stage, they represent fused body scales rather than tesserae like those of the psammosteids.

The plates and tesserae of *C. kingi* and *C. graticulata* may have been capable of limited marginal growth of both the deep and superficial layers, the marginal spongy tissue of *C. kingi* being perhaps a zone of active growth (Dineley 1953).

### *Affinities of the Corvaspididae*

Woodward (1934) described *Corvaspis kingi* as a cyathaspidid largely because of its histological structure. Dineley (1953) noted that *Corvaspis* possessed median, orbital, and ridge plates as well as scales. Owing to the complete enclosure of the orbits in the orbital plate, he placed *C. kingi* and *C. graticulata* in the new family Corvaspididae, and supposed *Corvaspis* to have been rather flat and *Drepanaspis*-like, with median dorsal and ventral discs surrounded by scaled areas.

Denison (1953) noted the similarity of ornamentation and microstructure of *Cardipeltis* to those of *Corvaspis*, but concluded that *Corvaspis* was too poorly known to permit close comparison. Detailed study of histological structure led

Bystrow (1955) to compare *Corvaspis* with *Kallostrakon*, which could in turn be compared with *Psammolepis*. Stensiö (1958) raised Dineley's (1953) Corvaspididae to the order Corvaspida. He proposed that *Penygaspis* and *Strosispherus* should be included in the Corvaspida because of the similarity of their ornamentation to that of *Corvaspis*.

In 1960 Tarlo recognized median, orbital, postorbital, and lateral plates; in additional British material he reinterpreted the 'ridge plates' (Dineley 1953) as branchial plates and inferred, from the pattern of ornamentation, that fields of tesserae separated the main plates. To him, these tesserae implied that *Corvaspis* was related to the psammosteids. Although initially placed in the Psammosteidae (Tarlo 1962a), *Corvaspis* was subsequently (Tarlo 1964) retained as a psammosteid within the order Psammosteiformes, but the Corvaspididae were entered in the suborder Tesseraspida. Tarlo (1960, 1962a, b, 1964, 1965) has suggested that *Cardipeltis* might be descended from the primitive psammosteids via *Corvaspis*. Such a relationship is based on his interpretation of the dentine ornament of plates of *Corvaspis* and *Cardipeltis*, both of which were supposed to show stages of elimination of tesserae. Fusion of the dorsal and branchial plates of *Corvaspis* was postulated as a means by which the large dorsal plates of *Cardipeltis* could have evolved (Tarlo 1962a). When describing better specimens of *Cardipeltis*, Denison (1966) was reluctant to suggest a close relationship with the still poorly known *Corvaspis*.

Thorsteinsson and Tozer (1963) noted a cyathaspidid which 'compares favourably with *Corvaspis*' in the Peel Sound Formation, approximately 20 km east of the locality for the *Corvaspis* sp. already mentioned. Although a description of this form has never been provided, both Obruchev (1967) and Halstead (1973) used this evidence to group *Corvaspis* with the cyathaspidids. Halstead (1973) concluded that the lineage *Kallostrakon*-*Corvaspis*-*Cardipeltis* must ultimately have had cyathaspidid affinities. In his evolutionary scheme, the pteraspids and cyathaspidids were independently evolved from tessellated ancestors. Within the *Corvaspis*-Cyathaspididae lineage, *Corvaspis* was regarded as a precursor of *Cardipeltis* and of the true Cyathaspididae.

If primitive members of that family had a continuous dorsal shield and later forms had irregular plates and tesserae, the Corvaspididae may have been initially derived from the Cyathaspididae, and later evolved forms with irregular plates and tesserae. It is tempting to suggest that the corvaspidids also gave rise to the wholly and partially tesserated forms such as *Kallostrakon*, *Tesseraspis*, and *Oniscolepis*.

#### *Distribution and biostratigraphic significance of Corvaspis*

*Corvaspis* ranges from the Downtonian *symondsi* Zone to the Dittonian *crouchi* Zone of Ball and Dineley (1961) in Britain. Occurrences of *Corvaspis* appear to be of similar age throughout Europe.

In the Red Bay Group of Vestspitsbergen (Dineley 1953), *C. kingi* occurs throughout the Fraenkelryggen Formation; *C. graticulata* is restricted to the *vogti* Horizon at the base of the Ben Nevis Formation. *C. kingi* is also present in the Chortkov Horizon of Podolia (Stensiö 1944; Dineley 1953) and a form which was subsequently referred to *C. karatajuteae* (Tarlo 1965), occurs in the Til'ze Suite of Lithuania (Karatajute-Talimaa 1962; Obruchev and Karatajute-Talimaa 1967); *Corvaspis* sp.



indet. has been described from the Beyrichienkalk erratics of the Berlin region (Gross 1961). The genus is everywhere commonly associated with traquairaspidids and cyathaspidids; it occurs with pteraspidids in the Dittonian of Britain, the Chortkov Horizon and the upper parts of the Fraenkelryggen and Ben Nevis Formations.

Although the *Corvaspis*-traquairaspidid-cyathaspidid assemblage is typical of the Late Downtonian (*sensu* White 1950a) of Europe, the same forms are associated in Wenlockian or Ludlovian strata on Prince of Wales Island in Arctic Canada (Turner and Dixon 1971; Dixon *et al.* 1972). In the Peel Sound Formation of Somerset and Prince of Wales Islands (Thorsteinsson and Tozer 1963; Broad 1968, 1971; Broad and Dineley 1973) *Corvaspis* occurs with Late Silurian invertebrates (Broad and Dineley 1973). *C. arctica* occurs there in association with the 'Early Downtonian' (now Pridoli) index fossil, *Hemicyclaspis purchisoni* (Egerton).

The specimens of *Corvaspis* cf. *C. kingi* reported from the Snake River area of Northern Yukon (Dineley 1965a), more closely resemble *Natlaspis planicosta* gen. et sp. nov. from the Delorme Formation (p. 140).

Accepting the distribution of Silurian continents postulated by McKerrow and Ziegler (1972) and others, it seems that the Corvaspididae, like the Traquairaspididae, were established in the tropical shelf seas of the North American continent. When the North American and European continents collided in the late Downtonian the Corvaspididae were able to reach Europe. As with the Traquairaspididae, their exploitation of the new extensive brackish and freshwater environments may have accompanied or shortly preceded their appearance in Europe. Thus the Corvaspididae are of similar biostratigraphic value to the Traquairaspididae (see p. 44).

#### FAMILY CYATHASPIDIDAE KIAER, 1932

*Diagnosis* (after Denison 1964). Small Heterostraci with carapace consisting of dorsal shield, ventral shield, paired branchial, oral, lateral, and suborbital plates. Postbranchial lobes commonly developed, but cornual plates absent; dorsal spine typically absent. Orbits bounded above by dorsal shield and below by suborbital plates; branchial openings typically situated between dorsal shield and branchial plate. Scales large, including median dorsal, dorso-lateral, ventro-lateral, and median ventral rows. Ornamentation typically of dentine ridges with smooth or scalloped edges; lateral line canals situated in cancellous layer and opening to surface by pores.

*Remarks.* Denison's (1964) revision of the Cyathaspididae included a review of previous classifications; eighteen genera were grouped into five subfamilies: Tolypelepidinae, Cyathaspidinae, Irregulareaspidinae, Poraspidinae, and Ctenaspidinae. His classification is accepted here with slight modifications; *Dikenaspis* is removed from the Irregulareaspidinae to the Cyathaspidinae, the anastomosing lateral line systems of *Dikenaspis* and *Irregulareaspis* being regarded as products of parallel evolution within the two subfamilies (p. 109). Two new genera have been erected: *Asketaspis* is referred to the Tolypelepidinae and *Nahanniaspis* to the Irregulareaspidinae.

## Subfamily TOLYPELEPIDINAE Denison, 1964

*Diagnosis* (after Denison 1964). Dorsal shield apparently composed, in part, of fused scales and subdivided into epitega. Dentine ridges largely short; central ridges of scale components broader and higher than surrounding ridges. Central ridge pattern elliptical, rostral ridge pattern transverse; postrostral field may be distinguishable.

*Genera.* *Tolypelepis* Pander and *Asketaspis* gen. nov.

## Genus TOLYPELEPIS Pander, 1856

*Synonymy.* Prior to 1964, see Denison (1964).

1964 *Tolypelepis* Pander; Stensiö.

*Diagnosis* (after Denison 1964). Dorsal shield broad, preorbital length short (orbital ratio 0.13–0.14). On central epitegum and postrostral field, dentine ridges short and grouped into scale-like units with narrower, lower ridges arranged around a coarser, higher central ridge.

*Type species.* *Tolypelepis undulatus* Pander.

*Other species.* *T. timanica* (*nomen nudum*) Kossovoy and Obruchev; *T. lenzi* sp. nov.

*Tolypelepis lenzi* sp. nov.

Plate 6, fig. 3; text-fig. 21

*Derivation of name.* After Dr. A. Lenz, who collected this specimen.

*Diagnosis.* Dorsal shield small (median length 27 mm), broad (width ratio 0.74) with orbital notches anteriorly placed (orbital length ratio 0.13). Dentine ridges short (0.5–4.0 mm), non-uniform and with rounded crests; average ridge density on central epitegum five per mm, on lateral epitega eight per mm. Epitegal subdivisions distinct; lateral epitega with anterior orbital field, central epitegum with post-rostral field. Ridges on central epitegum and post-rostral field grouped into units which are scale-like posteriorly; central ridge of each unit elevated. Ridges on rostral and lateral epitega approaching uniform height, grouped into units only on internal border of lateral epitega. Rostral epitegum with transverse ridges, except laterally, where arrangement is concentric. Lateral line pores inconspicuous.

*Holotype.* NMC 13768, an almost complete dorsal shield (Pl. 6, fig. 3; text-fig. 21).

*Locality.* CS YB10 Horizon 9F.

*Description.* Dimensions of dorsal shield:

Median length 27.0 mm			
Maximum width	20.0 mm	Width ratio	0.74
Pineal length	6.0 mm	Pineal length ratio	0.22
Orbital length	4.5 mm	Orbital length ratio	0.13
Orbital width	14.0 mm	Orbital width ratio	0.52

The single dorsal shield, which is incomplete posteriorly and postero-laterally, is short and broad, with maximum width posteriorly. The rostral margin is broadly

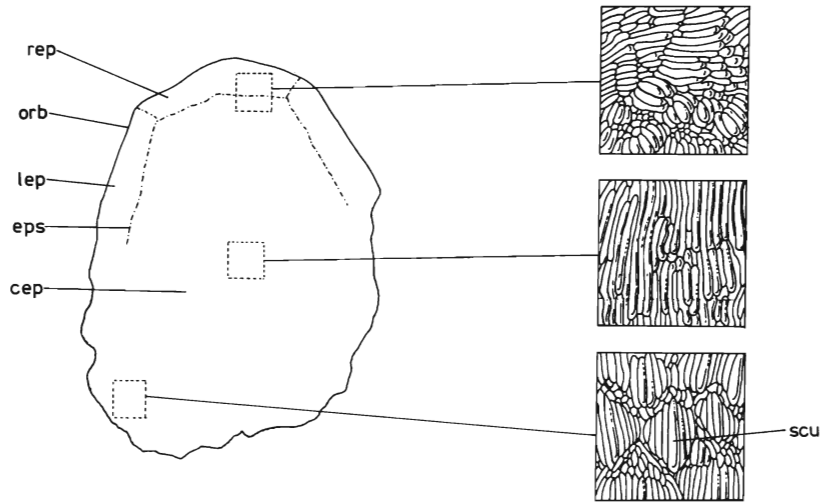

TEXT-FIG. 21. *Tolypelepis lenzi* sp. nov., variation in ornamentation on dorsal shield (NMC 13768, holotype); plan view  $\times 1.875$ ; detail  $\times 7.5$ . cep, central epitegum; eps, epitegal suture; lep, lateral epitegum; orb, orbit; rep, rostral epitegum; scu, scale unit.

rounded and the orbital notches are shallow; the pre-orbital processes are not visible. Division into epitega is distinct, a post-rostral field being distinguished from the central epitegum, and an orbital field being demarcated from the lateral epitega by a row of tubercles; all epitegal sutures are bordered by fine tubercles approximately 0.05 mm in diameter. The pineal region is not preserved.

Ornamentation is of short (0.25–4.0 mm), inflated, non-uniform dentine ridges of high relief (Pl. 6, fig. 3). Over much of the central epitegum and post-rostral field, ridges are grouped into units in which low, narrow (0.1–0.2 mm) ridges are grouped around a wider (0.3–0.4 mm) central ridge; such units are absent in the centre of the central epitegum, where ridges are short, non-uniform, and have a generally longitudinal arrangement (text-fig. 21). Units on the anterior two-thirds of the central epitegum are narrow (1 mm) and 1–4 mm long; toward the posterior of the central epitegum, they are rhomboidal and more closely resemble fused scales (text-fig. 21).

#### EXPLANATION OF PLATE 6

- Fig. 1. *Asketaspis interstincta* gen. et sp. nov. Incomplete dorsal shield (NMC 19767, holotype),  $\times 2$  (see text-fig. 22).  
 Fig. 2. *Ptomaspis* cf. *P. canadensis* Denison. Incomplete dorsal shield (NMC 21423),  $\times 2$ .  
 Fig. 3. *Tolypelepis lenzi* sp. nov. Dorsal shield (NMC 13768, holotype),  $\times 2$  (see text-fig. 21).  
 Figs. 4–6, 11. *Archegonaspis* sp. indet. 4, Type 2, incomplete dorsal shield (NMC 19769),  $\times 2$ . 5, Type 3, incomplete dorsal shield (NMC 19768),  $\times 2$ . 6, Type 4, incomplete dorsal shield (NMC 19764),  $\times 2$ . 11, Type 1, incomplete dorsal shield (NMC 21425),  $\times 2$ .  
 Figs. 7, 9, 10. Cyathaspidinae indet. 7, Type 1, lateral epitegum (NMC 12940),  $\times 2$ . 9, Type 3, fragment of dorsal shield (NMC 21435),  $\times 2$ . 10, Type 4, incomplete dorsal shield (NMC 21433),  $\times 2$ .  
 Fig. 8. *Vernonaspis* sp. indet. Dorsal shield fragment (NMC 19772),  $\times 2$ .  
 Fig. 12. *Vernonaspis tortucosta* sp. nov. Dorsal shield (NMC 19713, holotype),  $\times 2$ .  
 Fig. 13. ?*Cyathaspis* sp. indet. Incomplete dorsal shield (NMC 21508),  $\times 2$ .



DINELEY and LOEFFLER, Cyathaspids

On the posterior margin of the shield, scale-like units are up to 2.5 mm wide and 1.5 mm long; each has an elevated median ridge, low lateral ridges being longer posteriorly than anteriorly. These scale-like units have an imbricated appearance.

On the lateral epitega, ridges are narrower (eight per mm) and are of almost uniform height; only adjacent to the central epitegum are ridges grouped into units. An orbital field, with ridges parallel to the margin or the orbital notch, is demarcated from the rest of the lateral epitegum by a row of small tubercles. On the rostrum, ridges are of uniform height and are up to 2 mm long; they are slightly broader (five per mm) than on the lateral epitega. Their arrangement is broadly transverse, except laterally, where several ridges are concentric about points on the rostral margin.

Lateral line pores are not distinguishable.

*Remarks.* *T. undulata* is the only species of *Tolypelepis* previously described; *T. lenzi* differs from the type species in its smaller size and finer ornamentation. Although the most posterior scale-like units of *T. lenzi* are similar to those of *T. undulata*, the units of the rest of the central epitegum are less scale-like than those of equivalent position in the type species. Even in this unique and incomplete specimen, these differences are regarded as adequate for the distinction of a new species.

*Biostratigraphic significance.* *Tolypelepis* was originally described from the Ohesaare Stage of Saaremaa (Pander 1856), which is now regarded as Late Downtonian (*sensu* Allen and Tarlo 1963) (Kaljo, *cited in* Mark-Kurik 1969). Fragments of the species have been reported from the upper part of the underlying Kaugatuma Stage (Mark-Kurik 1969), which is also correlated with the Downtonian (Mark-Kurik 1969). Fragmentary material from the Berlin erratics of Beyrichienkalk (Gross 1961) were compared with *T. undulata*; this is probably of similar age to the occurrences in Saaremaa. *T. timanica* was listed by Kossovoy and Obruchev (1962) from the Eptarma Beds of Northern Timan; according to Obruchev and Karatajute-Talimaa (1967), the vertebrate fauna suggests the *Traquairaspis* zones of the Anglo-Welsh borders. *Tolypelepis* sp., listed from the zone of *T. pococki* in the Anglo-Welsh area by White (1956) has not been figured. A new species of *Tolypelepis* associated with Llandoveryan or Wenlockian graptolites in the Cape Phillips Formation of Cornwallis Island, Arctic Canada (Thorsteinsson 1959) has not yet been figured or described.

Thus, although *Tolypelepis* has been described only from the Downtonian, it may extend from the Llandoveryan to the *Traquairaspis* zones of the Downtonian.

#### Genus ASKETASPIS gen. nov.

*Diagnosis.* Dorsal shield of moderate dimensions and rather uniform width, divided into epitega by a band of short ridges and tubercles. On central epitegum, dentine ridges short, of non-uniform height, and grouped into units, which are more or less scale-like. Pre-orbital processes, maxillary brim and postbranchial lobes well developed.

*Type species.* *Asketaspis interstincta*.

*Asketaspis interstincta* sp. nov.

Plate 6, fig. 1; text-fig. 22

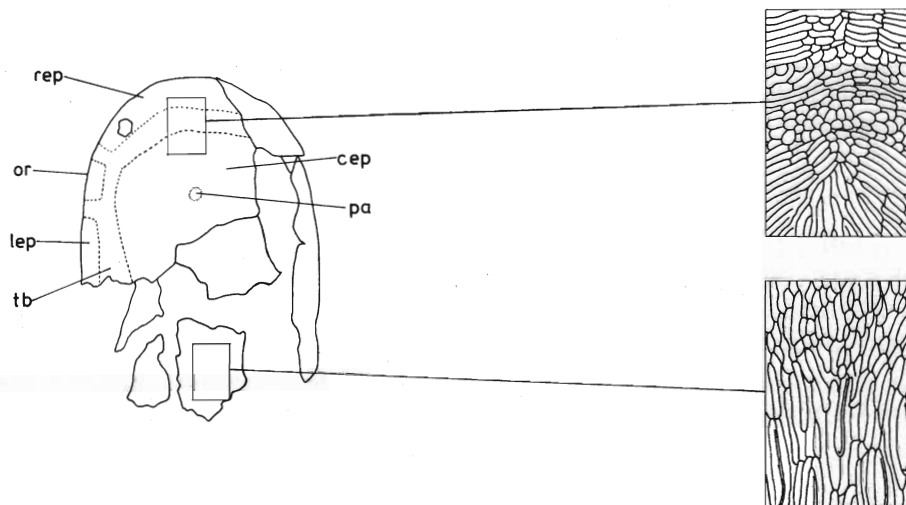
**Diagnosis.** As for genus, the type species being the only species.**Holotype.** NMC 19767, incomplete dorsal shield (Pl. 6, fig. 1; text-fig. 22).**Other material.** NMC 19773, incomplete dorsal shield.**Locality.** GSC 69017.

TEXT-FIG. 22. *Asketaspis interstincta* gen. et sp. nov., variation in ornamentation on dorsal shield (NMC 19767, holotype); plan view  $\times 1.875$ , detail  $\times 7.5$ . *cep*, central epitegum; *lep*, lateral epitegum; *or*, orbit; *pa*, pineal macula; *rep*, rostral epitegum; *tb*, tuberculate band.

**Description.** The dorsal shield, which is at least 30 mm long and 21 mm wide, is of rather uniform width and has a broadly rounded rostral margin (Pl. 6, fig. 1). Pre-orbital processes are well developed and the maxillary brim is broad. A ventro-lateral brim, 1.25 mm wide, extends along the lateral margin of the shield between the orbit and the branchial notch; postbranchial lobes are moderately well developed.

Ornamentation is of short dentine ridges with an average density of 6.5 per mm. Division into epitega is distinct; a band of short ridges and tubercles borders the anterior and lateral margins and divides the rostral and lateral epitega from the orbital field. Ornamentation within the band is of short ridges and tubercles, which are slightly wider and flatter than those of the epitega; several very narrow ridges occupy a median position within the band (text-fig. 23). Ridges on the rostral epitegum have a largely transverse arrangement, being straight anteriorly but curved anterolaterally. On both the orbital and the lateral epitega, short ridges of uniform height are arranged parallel to the margin of the shield. A post-rostral field is not distinctly demarcated, but dentine ridges in that region of the central epitegum are of uniform height and tend to converge anteriorly; the pineal macula is indistinct. On the rest

of the central epitegum, ridges are short and not of uniform height; their arrangement is longitudinal to slightly elliptical. Locally, the ridges are grouped into areas with an elevated median ridge; these units become more scale-like toward the posterior part of the shield.

*Remarks.* Short dentine ridges of non-uniform height occur in *Tolypelepis* and in *Ptomaspis*, but in those genera the ridges are grouped into scale-like areas only on the posterior part of the shield. Although the shield differs in detail from that of both *Ptomaspis* and *Tolypelepis*, it is closer to the latter in shape and in its distinct subdivision into epitega. The distinct inter-epitegal band of tubercles, the detail and low relief of the ornamentation, and the distinction of an orbital field are adequate to characterize a new genus, *Asketaspis*. This genus is referred to the Tolypelepidinae since, although its ornamentation is of lower relief than that of *Tolypelepis*, it has all the diagnostic features of the subfamily as defined by Denison (1964).

#### Subfamily CYATHASPIDINAE Denison, 1964

*Diagnosis* (after Denison 1964). Dorsal shields with distinct epitega and little or no trace of scale components. Dentine ridges largely long; ridge pattern commonly slightly elliptical or nearly longitudinal on the central epitegum and transverse on the rostral epitegum. A post-rostral field may be distinct.

*Genera.* *Ptomaspis* Denison, *Cyathaspis* Lankester, *Archegonaspis* Jaekel, *Seretaspis* Stensiö, *Vernonaspis* Flower and Wayland-Smith, *Pionaspis* Denison, *Listraspis* Denison, *Dikenaspis* Denison.

#### Genus PTOMASPIS Denison, 1963

*Synonymy.* See Denison 1964.

*Diagnosis* (after Denison 1964). Dorsal shield of moderate proportions with broadly rounded rostrum and gently rounded posterior margin. Ornamentation of high and low dentine ridges, locally subdivided into short lengths and tubercles. On the posterior part of dorsal shield, ridges grouped into scale-like areas. Rostral epitegum with short, transverse ridges anteriorly, grading through denticles into longitudinal ridges in the post-rostral field.

*Type species.* *Ptomaspis canadensis* Denison.

#### *Ptomaspis* cf. *P. canadensis* Denison

Plate 6, fig. 2

*Material.* NMC 21423, internal mould of dorsal shield with fragments of skeletal material preserved on rostral margin and postero-lateral corners of shield.

*Locality.* GSC 69017.

*Description.* The dorsal shield is estimated to have been about 60 mm long and 40 mm wide, being widest posteriorly. In the region of the orbits, which are rather posteriorly placed (orbital length ratio 0.17), the shield is 25 mm wide. Pre-orbital processes are well developed and the orbital notches are deep; the shield appears to have been slightly vaulted. The ornamentation on the rostral fragment is of short

dentine ridges and tubercles approximately 0.5 mm wide and 0.5–2.0 mm long; the pattern is transverse on the anterior part of the rostrum and parallel to the shield margin in the orbital region. On the postero-lateral margin of the shield, ridges are short, of non-uniform height and width but rather low relief. Their arrangement forms a pattern resembling fused, imbricated scales (Pl. 6, fig. 2). The ornament of each lozenge-shaped unit comprises short, oblique ridges anteriorly and longer, longitudinal ridges posteriorly. The median longitudinal ridge of each unit is wider and higher than the rest.

*Remarks.* The orbital notches and shape of the shield indicate the cyathaspidid affinities of this specimen. Numerous, distinct scale-like units are known only in *Tolyepepis*, *Asketaspis* gen. nov., and *Ptomaspis*. This specimen is excluded from *Tolyepepis* and *Asketaspis* by the size of the dorsal shield; the style of ornamentation and the size of the shield suggest close similarity to *Ptomaspis*.

*Biostratigraphic significance.* *P. canadensis*, the type and only species, is from a fauna which may be Ludlovian or Pridolian age in the Beaver River area of south-eastern Yukon (Denison 1963). Forms resembling *Ptomaspis* have been reported from the Early Wenlockian and Early Ludlovian of Cornwallis Island, in Arctic Canada (Thorsteinsson 1967).

#### GENUS *VERNONASPIS* Flower and Wayland-Smith, 1952

*Synonymy.* See Denison (1964).

*Diagnosis* (after Denison 1964). Dorsal shield moderately broad to narrow (width ratio 0.54–0.64) with anteriorly placed orbits and pineal body (orbital ratio 0.10–0.14; pineal ratio 0.20–0.22). Postbranchial lobes long (postbranchial ratio 0.34–0.45), but narrow. Dentine ridges fine to moderately coarse (five to nine ridges per mm), commonly with gently convex crests. Rostral epitegum with transverse ridges, post-rostral field not distinct from central epitegum.

*Type species.* *Vernonaspis allenae* Flower and Wayland-Smith.

#### *Vernonaspis sekwiae* Denison, 1964

Plate 7, figs. 1–4; text-fig. 23

*Synonymy.* 1964 *Vernonaspis sekwiae* new species; Denison.

*Diagnosis* (supplemented after Denison 1964). Dorsal shield approximately 33 mm long, with 5.5 to 6.5 dentine ridges per mm; posterior margin of shield with slight median lobe. Width ratio of dorsal shield approximately 0.64; orbital and pineal ratios greater than in other species. Ventral shield deeply vaulted, with concave anterior margin.

*Holotype.* NMC 10036, incomplete dorsal shield (Denison 1964, figs. 123–124).

*Type locality.* Top of Mount Sekwi, beside Keele River, North West Territories, Canada; latitude 63° 28' N., longitude 128° 40' W. (California Standard Co. locality Z-29-61).



*Referred specimens.* Nineteen dorsal shields (all incomplete): NMC 19700–19712, 19714–19718 (GSC 81050), NMC 13892 (CS YEx 37b). Twenty-four ventral shields (all incomplete): NMC 19719–19731, 19732a, b, 19733–19736, 19737a–c, 19738–19739 (GSC 81050).

*Localities for referred specimens.* GSC 81050, CS YEx 37b.

*Description of referred specimens.* Dimensions of dorsal shield:

	Range (mm)	Average (mm)	Number measured
Median length	31.0–36.0	33.3	8
Maximum width	21.0–24.0	22.2	5
Orbital width	13.0–15.0	13.8	9
Orbital length	4.0– 6.0	5.3	11
Pineal length	6.5– 9.0	7.9	6
Postbranchial length	11.5	11.5	2
	Range	Average	Number measured
Width ratio	0.61–0.75	0.68	4
Orbital width ratio	0.38–0.47	0.42	6
Orbital length ratio	0.12–0.17	0.16	7
Pineal length ratio	0.19–0.27	0.23	4
Postbranchial length ratio	0.36–0.41	0.39	2

Variation in the length of the dorsal shield and in the orbital and pineal lengths is largely a result of crushing; values are greater than in the holotype (Denison 1964), owing to forward protrusion of the rostral process.

The following can be added to Denison's (1964) original description: The posterior margin of the dorsal shield is almost transverse, but for a slight median lobe. Although there is one continuous ridge parallel to the rostral margin, the anterior rostral ridges are commonly subdivided into short lengths and tubercles. A distinct pineal macula is not present in every specimen; in those from which it is absent, the position of the pineal organ is marked by an elevated area (Pl. 7, figs. 1, 2).

Dimensions of ventral shield:

	Range	Average	Number measured
Length	30.0–32.0 mm	30.8 mm	6
Width	18.0–21.0 mm	19.3 mm	8
Width ratio	0.59–0.70	0.63	4

The ventral shield is deeply vaulted, when undistorted (Pl. 7, figs. 3, 4), and also has a distinct antero-posterior convexity. Dentine ridges are slightly coarser than on the dorsal shield, having a density of 5.0 to 5.5 per mm; ridges which are parallel to the anterior margin of the ventral shield may be considerably finer. The ventral shield is narrowest anteriorly, widening to the posterior end. The posterior margin is slightly drawn out, more so than that of the dorsal shield. The ridge pattern is largely longitudinal, with some anterior convergence; a band of transverse ridges runs parallel to the anterior margin.

*Remarks.* This material agrees well with Denison's (1964) *V. sekwiae* and closely resembles the holotype. It is more complete than that described by Denison.

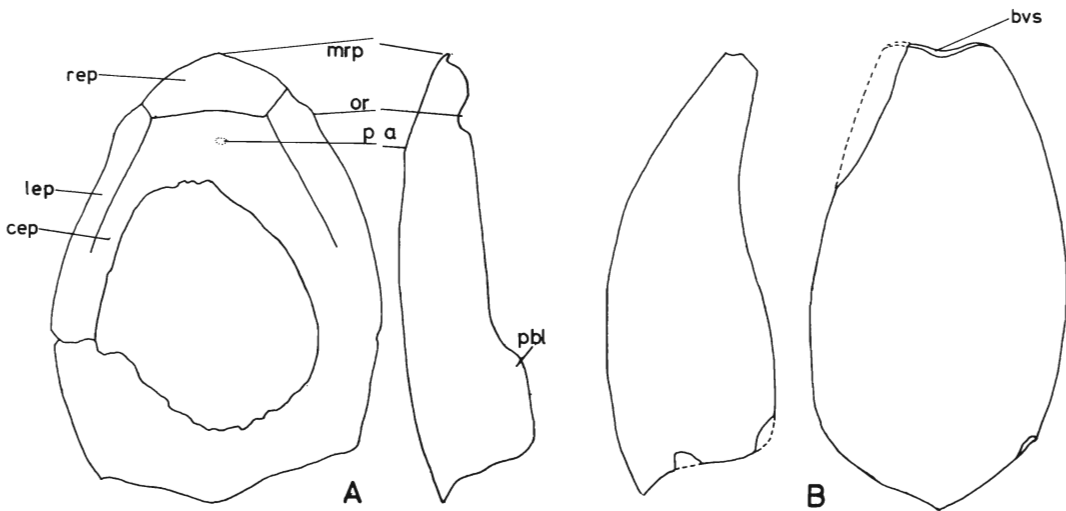

TEXT-FIG. 23. *Vernonaspis sekwiae* Denison. A, dorsal shield (NMC 19700); plan and lateral views  $\times 1.875$ . B, ventral shield (NMC 19720); plan and lateral views  $\times 1.875$ . *bvs*, band of transverse ridges; *cep*, central epitegum; *lep*, lateral epitegum; *mrp*, median rostral process; *or*, orbit; *pa*, pineal macula; *pbl*, postbranchial lobe; *rep*, rostral epitegum; *vs*, ventral shield.

The flat dorsal shield and deeply vaulted ventral shield of *V. sekwiae* suggest that it may have lived partially buried in mud, much as *Ctenaspis* is thought to have done (Dineley, in press).

*Biostratigraphic significance.* The exact position of GSC 81050 is not certain, but it appears to be close to the type locality of *V. sekwiae*, and may well be in the same horizon. Although Denison (1964), on the basis of associated corals and brachiopods, regarded this horizon as Late Ludlovian, Lenz (pers. comm.) considers that it could equally well be Pridolian.

#### *Vernonaspis* cf. *V. sekwiae* Denison

Plate 7, fig. 5

*Material.* NMC 13769-13801 in thirty-two blocks, each containing at least one shield fragment and many containing large numbers of entire but distorted shields.

*Locality.* CS YB1, Horizon 4F.

*Description.* The shields, which are abundant but poorly preserved, have undergone considerable distortion. The dorsal shields are subdivided into epitega, a post-rostral field not being separate from the central epitegum. A median process is present on the rostral margin; postbranchial lobes are well developed. The posterior margin of the dorsal shield is transverse, but for a small median lobe.

Ornamentation is of continuous dentine ridges (density five to six per mm), which are elliptical on the central epitegum, parallel to the lateral margins on the lateral epitega, and transverse on the rostral epitegum; the anterior part of the rostral epitegum commonly has an ornament of small tubercles.

*Remarks.* At this locality, shields of *Vernonaspis* are so abundant as to produce a virtual 'Vernonaspis conglomerate', shields being stacked one on top of another. They have undergone such distortion that the width ratio of the dorsal shield varies from 0.44 (NMC 13769) to 1.2 (NMC 13770, Pl. 7, fig. 5). The specimens are referred to *Vernonaspis* because of their distinct epitega, median rostral process, and post-branchial lobes. Species of *Vernonaspis* have been distinguished arbitrarily, on the basis of size and on coarseness of ridges; the ridge pattern shows such variation that it is unreliable (Denison 1964). Since these specimens are so distorted, it is difficult to identify them to species level. All appear to be the same species and they are compared with *V. sekwiae* Denison, because of similarity in the shape of the posterior margin of the shield and in the coarseness and arrangement of the dentine ridges.

*Vernonaspis tortucosta* sp. nov.

Plate 6, fig. 12

*Diagnosis.* A *Vernonaspis* resembling *V. sekwiae* in dimensions but lacking a posterior median lobe on dorsal shield. Ornamentation of dentine ridges, whorled in centre of central epitegum and around lateral line pores, converging postero-medially.

*Holotype.* NMC 19713, a complete but crushed dorsal shield (Pl. 6, fig. 12).

*Locality.* GSC 81050.

*Description.* Dimensions of dorsal shield:

	Median length 32 mm		
Maximum width	21 mm	Width ratio	0.66
Orbital width	13 mm	Orbital width ratio	0.41
Orbital length	6 mm	Orbital length ratio	0.19
Pineal length	7 mm	Pineal length ratio	0.22
Postbranchial length	10 mm	Postbranchial length ratio	0.31

Although all dimensions are within the range for those specimens referred to *V. sekwiae* Denison (p. 59), ornamentation of this specimen is so different as to merit a new species. In the middle of the central epitegum, ridges have a whorled arrangement, with smaller peripheral whorls and circlets in the region of the lateral line pores (Pl. 6, fig. 5). Ridges converge strongly on the mid-line at the posterior end of the shield, but this is no distinct median lobe. Postbranchial lobes are long and narrow; rostral and pre-orbital processes well developed and the pineal macula indistinct. Epitega conspicuous, but a post-rostral field is not demarcated from the central epitegum.

*Remarks.* The dimensions of this specimen are similar to those of *V. sekwiae*, but the absence of a posterior median lobe and the difference of ornamentation warrant its recognition as a separate species. The symmetrical arrangement of the whorled ridges is unlikely to be the result of disease or other damage.

*Vernonaspis* cf. *V. major* Denison

Plate 7, fig. 10

*Material.* NMC 21434, antero-lateral fragment of dorsal shield.

*Locality.* GSC 81050.

*Description.* Rostral and lateral epitega are distinguishable, but a post-rostral field is not apparent; the median rostral process is strongly developed, as is the pre-orbital process (Pl. 7, fig. 7). Rostral ornamentation is of transverse ridges posteriorly, grading into tubercles anteriorly and on the pre-orbital processes. Ridges curve around the orbital notch and the anterior part of the central epitegum; their density is five per mm.

*Remarks.* Although there are few details of ornamentation to distinguish this unique specimen from *V. sekwiae* Denison, which occurs at the same locality, the size difference is appreciable, the specimen being almost twice as large. Poor preservation prevents a specific identification, but the similar size suggests *V. major* Denison.

*Biostratigraphic significance.* *V. major* Denison was originally described from limestones and graptolitic shales of the Beaver River area of south-eastern Yukon (Denison 1963). Its age could lie anywhere within the Late Silurian (see p. 197).

?*Vernonaspis* sp. indet.

Plate 6, fig. 8

*Material.* NMC 19772, antero-lateral fragment of dorsal shield.

*Locality.* GSC 69017.

*Description.* The dorsal shield is of moderate dimensions and shows a marked subdivision into epitega, a distinct post-rostral field not being recognizable. The ornament is of both long and short, flat-topped dentine ridges of uniform height with a density of seven per mm. Anterior to the conspicuous pineal macula, the ridges of the central epitegum are short and irregularly arranged. On the small fragment of the postpineal area of the central epitegum, dentine ridges are long and largely longitudinally arranged, except in the region of lateral line pores. On the rostral epitegum, ridges are transverse posteriorly, becoming irregular anteriorly. One or more circular dentine ridges commonly enclose the pores of the supra-orbital lateral line canals. On that part of the lateral epitegum which is preserved, dentine ridges are arranged parallel to the margin of the orbital notch. There is a slight median protuberance on the rostral margin.

*Remarks.* The distinct epitega of the dorsal shield indicate cyathaspidinid affinities, the lack of a distinct post-rostral field suggesting a relationship with either *Vernonaspis* or *Pionaspis*. Although the rostral margin is poorly preserved, there is some indication of a median rostral protuberance, such as characterizes *Vernonaspis*. The presence of circular ridges around the supra-orbital lateral line pores is common to the two species *V. bamberi* Denison and *V. major* Denison, both of which occur in the Late Silurian Beaver River fauna of south-eastern Yukon (Denison 1963).

*Biostratigraphic significance.* All reliably dated occurrences of *Vernonaspis* are Late Silurian (see Broad and Lenz 1972).

### Genus PIONASPIS Denison, 1964

*Synonymy.* 1964. *Pionaspis* new genus; Denison.

*Diagnosis* (amended after Denison 1964). Dorsal shield large and relatively broad with distinct epitega but no post-rostral field. Orbital notches deep and anteriorly placed (orbital ratio approx. 0.14); median rostral process absent. Postbranchial lobes short and deep, with truncate anterior margins.

*Type species.* *Pionaspis planicosta* Denison, 1964.

#### *Pionaspis amplissima* sp. nov.

Plates 8, 9; text-fig. 24

*Diagnosis.* Dorsal shield 110–115 mm long, with width ratio of approximately 0.57. Ornamentation of flat-topped dentine ridges with density of 4.5 to 5.5 per mm. Orbital length ratio 0.13; pineal length ratio 0.21; postbranchial length ratio 0.43.

*Holotype.* NMC 19640, incomplete dorsal shield (Pl. 8, figs. 1, 2; text-fig. 24).

*Other material.* Fourteen incomplete dorsal shields: NMC 19621–19623, 19628, 19632–19633, 19637, 19639, 19675–19678, 19689, 19692 (GSC 69014, 69016, 81053).

Five incomplete ventral shields: NMC 19629, 19638, 19641, 19643, 19682 (GSC 69014, 81052, 81053).

Twenty-six isolated scales: NMC 12818, 12851, 12875–12876, 12882, 12888, 12927, 12936, 13005, 13214, 19611, 19592–19594, 19596, 19599, 19663–19665, 19667–19669, 19671, 19672a, b, 19691 (GSC 69014, 69017, 81051).

Nineteen indeterminate fragments: NMC 19624, 19626–19627, 19630, 19634–19636, 19642, 19648–19649, 19679–19681, 19683–19687, 19690 (GSC 69014, 69017, 81053).

*Type locality.* GSC 69014 (NMC 12818, 12851, 12875–12876, 12882, 12888, 12927, 12936, 13005, 13214, 19592–19594, 19596, 19611, 19621–19624, 19626–19628, 19630, 19632–19643, 19648–19649, 19663–19665, 19667–19669, 19671, 19672a, b).

*Other localities.* GSC 69017 (NMC 19678–19679, 19683, 19690–19692); GSC 81051 (NMC 19599); GSC 81052 (NMC 19682); GSC 81053 (NMC 19629, 19675–19677, 19680–19681, 19684–19687, 19689).

#### EXPLANATION OF PLATE 7

Figs. 1–3, 11, 12. *Vernonaspis sekwiae* Denison. 1, incomplete dorsal shield in plan view (NMC 19700),  $\times 2$ . 2, incomplete dorsal shield in side view (NMC 19700),  $\times 2$  (see text-fig. 23A). 3, incomplete dorsal shield showing lateral line canals (NMC 13802),  $\times 2$ . 11, ventral shield in plan view (NMC 19720),  $\times 2$ . 12, ventral shield in side view (NMC 19720),  $\times 1$  (see text-fig. 23B).

Fig. 4. Cyathaspidinae indet., Type 5. Incomplete dorsal shield, showing distinct lateral epitegum (NMC 13819),  $\times 2$ .

Fig. 5. *Vernonaspis* cf. *V. sekwiae* Denison. Incomplete, distorted, dorsal shield (NMC 13770),  $\times 2$ .

Figs. 6–8, 13. ?*Homalaspidella* sp. indet. 6, Type 2, incomplete dorsal shield (NMC 21426),  $\times 2$ . 7, Type 4, incomplete dorsal shield (NMC 19771),  $\times 2$ . 8, Type 1, incomplete dorsal shield (NMC 19779),  $\times 2$ . 13, Type 3, incomplete dorsal shield (NMC 19778),  $\times 2$ .

Fig. 9. *Homalaspidella* cf. *H. borealis* Denison. Incomplete dorsal shield and associated trunk scales (NMC 19765),  $\times 2$ .

Fig. 10. *Vernonaspis* cf. *V. major* Denison. Rostral fragment, showing median rostral process (NMC 21434),  $\times 2$ .



DINELEY and LOEFFLER, Cyathaspids

*Description.* Dimensions of dorsal shield:

	Range (mm)	Average (mm)	Number measured
Median length	110.0-115.0	112.5	2
Maximum width	55.0-66.0	60.5	2
Orbital width	42.0-43.0	42.5	2
Orbital length	12.0-15.0	13.5	2
Pineal length	21.0-24.5	22.75	2
Postbranchial length	52.0	52.0	1

Measurements from the holotype (NMC 19640) only, were used to calculate the following ratios: width ratio 0.57; orbital width ratio 0.42; orbital length ratio 0.13; pineal length ratio 0.21; postbranchial length ratio 0.43.

The large dorsal shield, which is deeply vaulted in uncrushed specimens, has a broadly rounded rostrum and well-developed postbranchial lobes. The pre-orbital processes are large and the orbital notches deep and rather ventrally situated. The postbranchial lobes have truncate anterior margins with an ornamentation of fine tubercles. The posterior margin of the shield is drawn out to a blunt median lobe. Epitega are distinct, but a post-rostral field is not demarcated from the central epitegum; the raised pineal area lacks a true macula (Pl. 8, fig. 1).

Ornamentation is of flat-topped dentine ridges with a density of 4.5 to 5.5 per mm. Ridges are largely transverse on the rostral epitegum, tending to be subdivided into tubercles anteriorly and to be irregularly orientated posteriorly. On the lateral epitega, ridges are largely longitudinal posteriorly but may be irregular anteriorly, except around the orbits, where they are parallel to the margin of the shield. On the central epitegum, ridge pattern is irregular and variable, but tends to converge on the mid-line. Differences in reflective properties of the surface layer reveal concentric markings, which are interpreted as growth lines (text-fig. 38), as discussed below (p. 105).

In the holotype, small patches of dentine ridges which are slightly coarser and more glossy than the normal ornamentation are superimposed on abraded ridges around the orbital region (Pl. 8, fig. 1). The anterior part of the rostrum is overlain by a band of transverse ridges of similar type, which appear to have been formed during repair of damage to the rostrum (Pl. 8, fig. 1; text-fig. 24).

In uncrushed specimens (e.g. NMC 19682, Pl. 9, fig. 2), the ventral shield is deeply vaulted. The anterior margin, although not well preserved in any of the specimens, appears to have a median notch and two pairs of antero-lateral notches, all of which are bordered by an anterior unornamented brim. The lateral margins of the ventral shield are almost straight, the shield being considerably wider posteriorly than anteriorly; the posterior part of the shield is not preserved.

Ventral ornamentation is of dentine ridges, with a density of four to five per mm. Medial dentine ridges tend to converge on the mid-line some distance behind the

---

EXPLANATION OF PLATE 8

Figs. 1, 2. *Pionaspis amplissima* sp. nov. Incomplete dorsal shield (NMC 19640, holotype),  $\times 1.75$  (approx.).  
1, plan view. 2, lateral view (see text-fig. 24).



DINELEY and LOEFFLER, *Pionaspis amplissima*



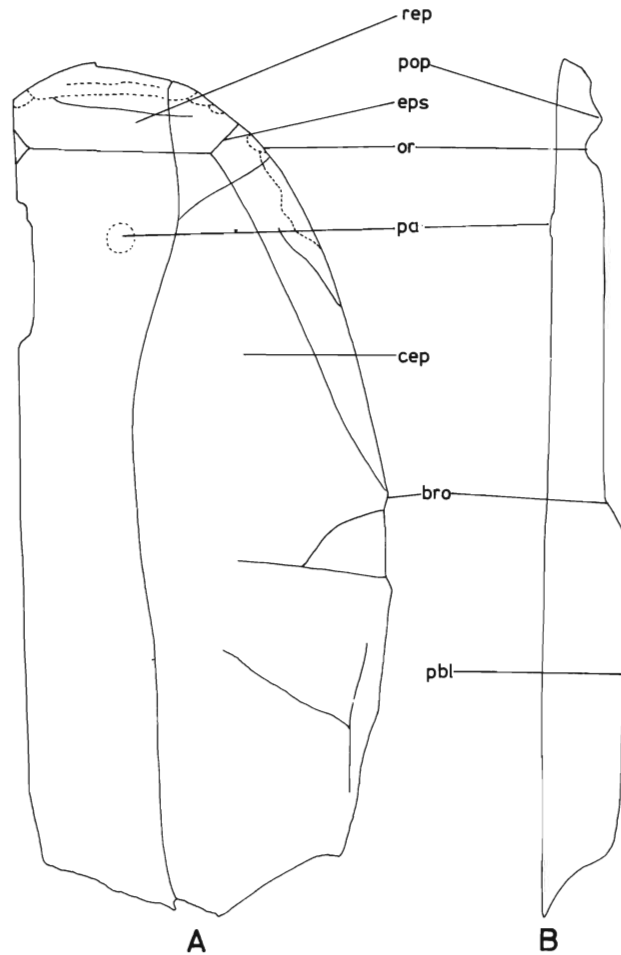

TEXT-FIG. 24. *Pionaspis amplissima* sp. nov., dorsal shield (NMC 19640, holotype); A, plan view; B, lateral view, both  $\times 1$ . *bro*, branchial notch; *cep*, central epitegum; *eps*, epitegal suture; *or*, orbit; *pa*, pineal macula; *pbl*, postbranchial lobe; *pop*, pre-orbital process; *rep*, rostral epitegum.

anterior margin of the shield; peripheral ridges describe a broad curve around the anterior part of the shield, with some irregularity. Parallel to the anterior margin, fine transverse ridges and small tubercles border the unornamented brim. Growth lines are apparent on the ventral as well as the dorsal shields (text-fig. 38).

Although extremely large, the scales of *P. amplissima* are of the typical cyathaspidid

#### EXPLANATION OF PLATE 9

Figs. 1-5. *Pionaspis amplissima* sp. nov. 1, incomplete ventral shield in lateral view (NMC 19682),  $\times 2$ . 2, incomplete ventral shield in plan view (NMC 19682),  $\times 2$ . 3, fulcral scale (NMC 19611),  $\times 2$ . 4, dorsal ridge scale (NMC 12818),  $\times 2$ . 5, lateral scale (NMC 12888),  $\times 2$ .

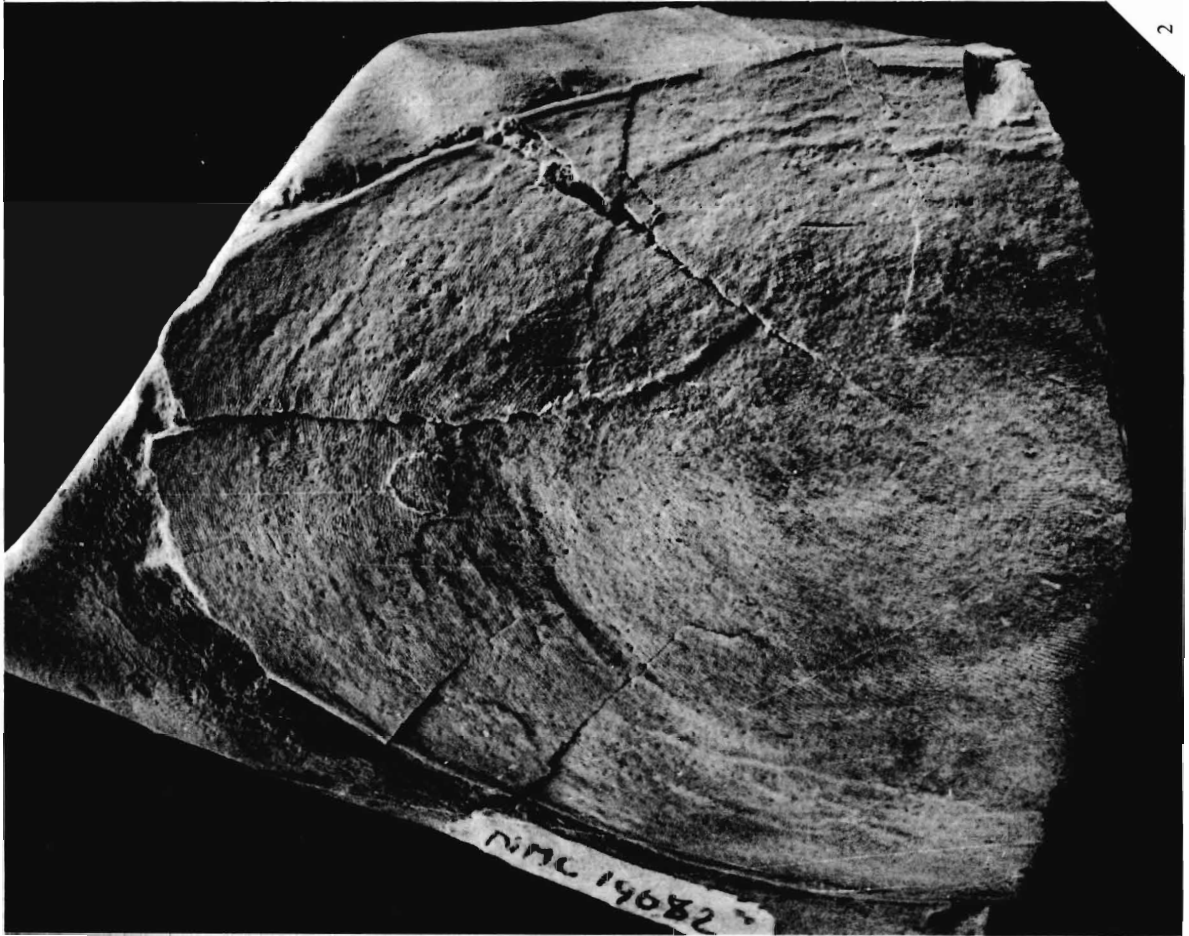
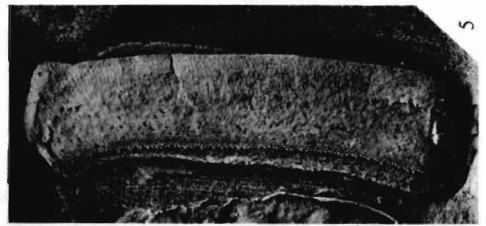
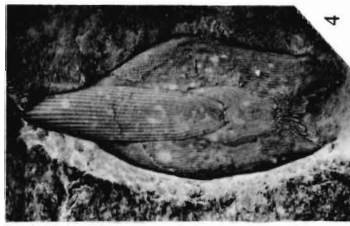

DINELEY and LOEFFLER, *Pionaspis amplissima*

type. Median ridge scales of various types are present: short, broad scales, commonly with an elevated median portion (Pl. 9, fig. 3), are presumed to have been more anteriorly placed than the long, narrow scales (Pl. 9, fig. 4). Lateral scales (Pl. 10, fig. 5), similar in shape to the dorso-lateral and ventro-lateral scales of *Nahanniaspis* and *Dinaspidea* (p. 88), are common. It is not possible to determine whether these are dorso-lateral or ventro-lateral scales; they may include both. Small asymmetrical scales may be 'additional' (p. 88) or, if the dorso-lateral and ventro-lateral scales were not of similar size, may be ventro-lateral scales as in *Poraspis* (Kiaer and Heintz 1935). The lateral scales reflect the decrease in size of scales toward the posterior end of the body.

Ornamentation on the scales is predominantly of longitudinal ridges, but these may be replaced anteriorly, on individual scales, by oblique ridges and small tubercles (Pl. 9, figs. 3, 5). The anterior, and commonly the antero-lateral, margins of many of the scales are bordered by unornamented brims (Pl. 9, fig. 5).

*Remarks.* The details of the ridge pattern vary within this species, do not conform to the generic diagnosis given by Denison (1964), and are omitted from the amended diagnosis. In other respects these specimens agree closely with the diagnosis, differing from the two established species in their larger size and coarser ornamentation. The length-width ratio of the dorsal shield of the holotype is smaller than that of either *P. planicosta* or *P. acuticosta* (Denison 1964).

Overgrowth of abraded dentine ridges by eruptive dentine in the holotype indicates that some repair of the superficial layer had occurred. Formation of secondary dentine for healing purposes known in *Corvaspis*, *Traquairaspis*, the psammosteids, and certain pteraspids, has not previously been reported in the Cyathaspididae.

*Biostratigraphic significance of Pionaspis.* *Pionaspis* was established for *P. planicosta* and *P. acuticosta*, from near Muncho Lake, B.C. (see p. 197 below). It has also been reported from Late Silurian strata on Prince of Wales Island (Broad and Dineley 1973).

?*Archegonaspis* sp. indet., Type 1

Plate 6, fig. 11

*Material.* NMC 21425, a dorsal shield, incomplete posteriorly.

*Locality.* GSC 58497.

*Description.* The dorsal shield is at least 26 mm long and 17.5 mm wide, its greatest preserved width being immediately anterior to the branchial notches. The orbital notches are deep, the pre-orbital processes moderately well developed, and the rostrum smoothly rounded; division into epitega is distinct (Pl. 6, fig. 11). Ornamentation is by uniform dentine ridges with a density of five to six per mm; ridges are short on the rostrum and post-rostral field, but are long posteriorly. The rostrum and post-rostral field share similar ornamentation of short, oblique ridges and tubercles; the pineal macula is conspicuously outlined by encircling ridges (Pl. 6, fig. 11). On the rest of the central epitegum, ridges have a largely longitudinal arrangement; on the lateral epitega, they lie parallel to the lateral margin of the shield. Lateral line pores are inconspicuous.

*Remarks.* Distinct division into epitega, the differentiation of a post-rostral field, and the absence of a median rostral process, suggest a relationship with *Archegonaspis* Jaekel. The rostral ornamentation is unlike that of established species of *Archegonaspis* (see Denison 1964); since rostral ornamentation is rather variable and the specimen is incomplete, it is referred to ?*Archegonaspis* sp. indet. Three other specimens from the District of Mackenzie also resemble *Archegonaspis*, but differ from one another in detail; they are referred to ?*Archegonaspis* sp. indet., Types 1-4.

?*Archegonaspis* sp. indet., Type 2

Plate 6, fig. 4

*Material.* NMC 19769, fragment of the anterior end of a dorsal shield.

*Locality.* GSC 69017.

*Description.* The dorsal shield, which is of moderate size, bears distinct epitega; the post-rostral field is demarcated from the central epitegum by the disruption of the pattern of ornamentation in the region of the supra-orbital lateral line canals (Pl. 6, fig. 4). Dentine ridges, which are short and broad (five per mm), have gently rounded crests and are of uniform height and width. On the rostral epitegum, ridges are long and transverse anteriorly, grading into short, curved ridges posteriorly. Pre-orbital processes are well developed and a maxillary brim is present. The lateral epitega are ornamented with short, straight ridges, arranged parallel to the shield margin (Pl. 6, fig. 4). On the central epitegum, both within the post-rostral field and posteriorly, ridges are short and uniform with a generally longitudinal arrangement. The pineal macula is conspicuous.

*Remarks.* In the absence of a median rostral process, the distinct subdivision into epitega, and the moderate size of the shield, this specimen resembles *Archegonaspis*. The post-rostral field of *Archegonaspis* is commonly more distinct than that of this specimen. Since the specimen is both unique and incomplete, it is referred to ?*Archegonaspis* sp. indet., Type 2; it differs from Type 1 both in the size of the shield and the pattern of ornamentation.

?*Archegonaspis* sp. indet., Type 3

Plate 6, fig. 5

*Material.* NMC 19768, an incomplete dorsal shield.

*Locality.* GSC 81050.

*Description.* The dorsal shield, which is approximately 38 mm long and 25 mm wide, is divided into distinct epitega (Pl. 6, fig. 5). The rostrum is broadly rounded and has a narrow maxillary brim. The pre-orbital processes are moderately well developed and the orbital notches are deep and rather anteriorly placed (orbital length ratio 0.14). The posterior margin of the shield is transverse, but for a small median lobe. Ornamentation is of long dentine ridges, with an average density of four per mm; these are arranged transversely on the rostrum and parallel to the lateral margins of the shield on the lateral epitega. A post-rostral field is not developed,

ridges on the central epitegum all being longitudinal. Parallel to the posterior margin of the central epitegum, longitudinal ridges are interrupted by a narrow band of tubercles and a median rhomboidal, scale-like unit is demarcated by discordance of ridges (Pl. 6, fig. 5). The posterior margin of the scale-like unit forms a median lobe on the posterior margin of the shield.

*Remarks.* In the size of the shield, the presence of distinct epitega, and the absence of a median rostral lobe, this specimen resembles *Archegonaspis*. In *Archegonaspis*, however, the post-rostral field is commonly demarcated from the central epitegum. The posterior scale-like area and the transverse band of tubercles may represent scales which have been incorporated into the shield. A similar band of tubercles is present in the holotype of *A. lindstromi* Kiaer (see Denison 1964, p. 363).

*?Archegonaspis* sp. indet., Type 4

Plate 6, fig. 6

*Material.* NMC 19764, a dorsal shield.

*Locality.* GSC 81050.

*Description.* Dimensions of dorsal shield:

	Median length 32 mm		
Maximum width	24.0 mm	Width ratio	0.75
Orbital width	13.0 mm	Orbital width ratio	0.41
Orbital length	4.5 mm	Orbital length ratio	0.14
Pineal length	7.0 mm	Pineal length ratio	0.22

The dorsal shield is broadest in its posterior half, narrowing considerably toward the anterior end. The posterior margin is slightly convex and, like the rostral margin, lacks a median lobe. The orbital notches are shallow, but pre-orbital processes are moderately well developed. The ornamentation is of narrow dentine ridges (seven to eight per mm), which are of uniform height. A rostral epitegum and a post-rostral field are distinct but, owing to poor preservation, it is not possible to determine whether the lateral epitega were separate from the central epitegum. The ornamentation of both the rostral epitegum and the post-rostral field is of short dentine ridges and tubercles, which fan out from the conspicuous pineal macula. Ridges on the rest of the shield have a slightly elliptical arrangement, with local irregularities.

*Remarks.* Despite poor preservation of the posterior and lateral parts of the shield, the distinct post-rostral field suggests affinities with *Archegonaspis*. The patterns of ornamentation and density of ridges are unlike those of established species of *Archegonaspis*; this specimen is therefore referred to *?Archegonaspis* sp. indet. and distinguished as Type 4 by details of ornamentation.

*Biostratigraphic significance of Archegonaspis.* Previous occurrences of *Archegonaspis* are restricted to the Silurian. In Europe the genus is known from the Early and Middle Ludlovian, and questionably from the Early Downtonian (see Denison 1964); in Canada Thorsteinsson (1967) has reported *Archegonaspis* from the Late Wenlockian and Early Ludlovian of Cornwallis Island.

*?Cyathaspis* sp. indet.

Plate 6, fig. 13

*Material.* NMC 21508a, a shield fragment.

*Locality.* GSC 81050.

*Description.* Although estimated to be three-quarters complete, the length of the shield is only 20 mm. The ornament consists of short, coarse, ridges separated by finer ridges (Pl. 6, fig. 13). The coarse component is in the form of non-serrated, lachrymiform, tubercles 2.0–2.5 mm long and 0.75–1.25 mm wide. The finer interstitial ridges, which are continuous along the length of the shield, have a density of six to seven per mm. Both coarse and fine ridges are sharp-crested; coarse ridges are separated from one another by four to eight fine ridges.

Except where they form paired postero-lateral crests (Pl. 6, fig. 8) coarse ridges are absent from the posterior quarter of the shield; fine ridges converge posteriorly on a prolonged and slightly upturned posterior median crest. The anterior margin of the shield is not preserved and little detail of the lateral margin is visible.

*Remarks.* The non-uniform dentine ridges and postero-median crest of this small poorly preserved specimen suggest a relationship with *Cyathaspis*.

*Biostratigraphic significance.* *Cyathaspis* appears to be exclusively Silurian; it occurs in the ?Wenlockian (Obruchev 1938) of the U.S.S.R., but is otherwise only known from the Late Ludlovian and 'Early Downtonian' (see Denison 1964, and above). *C. miroshnikovi* (*nomen nudum*, Obruchev 1938) from the Gedinnian of Siberia was subsequently referred to *Steinaspis* (Obruchev 1964).

## Cyathaspidinae indet., Type 1

Plate 6, fig. 7

*Material.* NMC 12940, fragment of lateral margin of dorsal shield; NMC 19625, 19629, indeterminate plate fragments.

*Locality.* GSC 69014.

*Description.* The lateral epitegum of NMC 12940 (Pl. 6, fig. 7) is short and broad, with a large orbital notch. Dentine ridges on this and the two indeterminate fragments each have a median row of tiny pustules extending along the crest. The ridges are otherwise typically cyathaspidid, being long, parallel and of constant width; their density is 4.5–5.0 per mm. Short and contorted dentine ridges in a small area in the centre of NMC 19625 appear to have formed as a result of damage.

*Remarks.* These specimens are distinguished from other indeterminate cyathaspidinids from the District of Mackenzie by their pustulate ridges, a feature also found in *Allocriptaspis laticostata* Denison. The present material shows no other similarities to *Allocriptaspis*, the epitega indicating a relationship with the Cyathaspidinae rather than the Poraspidinae. Similar pustules occur in *Olbiaspis*, where they were considered by Obruchev (1964) to result from the fusion of rudiments of dermal denticles. A close relationship between this Cyathaspidinid and the rather bizarre *Olbiaspis* is improbable.

## Cyathaspidinae indet., Type 2

Plate 10, fig. 7

*Material.* NMC 19774, an incomplete and fragmented dorsal shield.

*Locality.* GSC 69017.

*Description.* The shield is estimated to have been about 40 mm long and 25 mm wide; division into epitega is distinct. The rostrum is broad and rounded, the pre-orbital processes moderately developed and the orbits shallow. The predominantly short (0.5–1.5 mm), flat-topped dentine ridges have a density of seven per mm. These ridges are of uniform height and are not grouped into tesserae or scale-like areas. On the lateral epitega, ridges are slightly longer than elsewhere, being widest at the lateral margin of the shield.

*Remarks.* The orbital notches confirm the cyathaspidid affinities of this shield, division into epitega and uniformity of the ridges being typical of the Cyathaspidinae. Subdivision of uniformly high ridges into short lengths and tubercles is not known in established cyathaspidinid genera. The poor preservation of this specimen makes it unwise to establish a new genus.

## Cyathaspidinae indet., Type 3

Plate 6, fig. 9

*Material.* NMC 21435, anterior fragment of a dorsal shield.

*Locality.* GSC 58497.

*Description.* The small dorsal shield, ornamented with relatively coarse ridges (average density 5.0–5.5 per mm) of uniform height, is divided into epitega (Pl. 6, fig. 9). The orbital notches are rather deep and the pre-orbital processes moderately developed; the rostral margin has a slight median convexity. The pineal macula is conspicuous, as are the pores of the supra-orbital lateral line canals. The rostral ornament is largely of transverse ridges, that of the post-rostral field fanning out except where interrupted by the concentric ridges which surround the pineal macula; rostral and post-rostral ridges tend to be rather short. Ridges on the lateral epitega have a slight angular discordance with those of the central epitegum.

*Remarks.* Cyathaspidinid affinities are shown by the subdivision of the dorsal shield into epitega. Among cyathaspidinids with uniform dentine ridges, a post-rostral field occurs only in *Archegonaspis*, but this specimen is excluded from that genus by its possession of a median rostral protuberance.

## Cyathaspidinae indet., Type 4

Plate 6, fig. 10

*Material.* NMC 21433, an incomplete dorsal shield.

*Locality.* GSC 69010.

*Description.* The shield is at least 27 mm long and approximately 20 mm wide. Epitega are moderately distinct but no post-rostral field is developed. Broad, low

dentine ridges (density 3.5 per mm) are transverse in the rostrum, longitudinal or irregular on the central epitegum, and parallel to the margins of the lateral epitega (Pl. 6, fig. 10). The pre-orbital process is moderately developed, and the rostral margin, which has a narrow maxillary brim, lacks a median lobe. The width of the shield is rather uniform, the orbits shallow, and the pineal macula conspicuous (Pl. 6, fig. 10).

*Remarks.* Epitega in the dorsal shield indicate cyathaspidinid affinities, but this specimen cannot with certainty be assigned to an established genus.

#### Cyathaspidinae indet., Type 5

Plate 7, fig. 4

*Material.* NMC 13819, an incomplete dorsal shield.

*Locality.* CS YG1, Horizon 6F.

*Description.* The shield, estimated to have been about 40 mm long and 26 mm wide, is complete only postero-laterally. The posterior margin has a distinct median lobe but no postbranchial lobes; lateral and central epitega are marked. Ornamentation is of long, flat-topped ridges with a density of four per mm. Ridges are longitudinal and continuous except posteriorly, where discontinuity of ridges suggests that a pair of lateral scales and a ridge scale are fused to the shield (Pl. 7, fig. 4).

*Remarks.* The epitega indicate cyathaspidinid affinities. Although the specimen is too incomplete to refer to a smaller taxonomic unit, the posterior margin of the shield resembles that of ?*Archegonaspis* sp. indet., Type 3 above.

#### Subfamily PORASPIDINAE Denison, 1964

*Diagnosis* (after Denison 1964). Epitega indicated faintly or not at all, scale components not evident. Dentine ridges long, and ridge pattern largely longitudinal, although commonly radiating on anterior parts of dorsal and ventral shields and diagonal on lateral parts of dorsal shield.

*Genera.* *Poraspis* Kiaer, *Americaspis* White and Moy-Thomas, *Homalaspidella* Strand, *Ariaspis* Denison, *Anglaspis* Jaekel, *Allocryptaspis* Whitely, *Liliaspis* Novitskaya.

#### Genus PORASPIS Kiaer, 1930

*Synonymy.* Prior to 1964, see Denison (1964).

1964 *Poraspis* Kiaer; Stensiö.

1973 *Poraspis* Kiaer; Novitskaya.

*Diagnosis* (after Denison 1964). Rostral region constricted anterior to orbits, anterior border with slight median convexity. Maxillary brim broad and covered with ridges parallel to anterior edge. Postbranchial lobes of dorsal shield long and strongly developed, posterior margins of dorsal and ventral shields with rounded median lobes. Dentine ridges fine (seven to eight per mm). Epitega indicated faintly or not at all. Ridge pattern mostly longitudinal, except on rostrum and anterior triangle of ventral shield, where it commonly fans out or is irregular. One or more ridges commonly arranged parallel to anterior edges of shields. Pineal macula distinct, lateral line pores large.

*Type species.* *Poraspis sericeus* (Lankester).



*Poraspis* cf. *P. polaris* Kiaer

Plate 10, figs. 1-4; text-fig. 25

*Material.* Twenty-five dorsal shields (ten complete or essentially complete): NMC 13218-13220, 19523, 19657, 19741-19755, 19758-19761, 21484). Three ventral shields: NMC 13211, 19756-19757. One specimen with dorsal and ventral shields, branchial and ?oral plate in place: NMC 19860.

*Localities.* GSC 69014 (NMC 13211, 13218-13220, 19523, 19657, 19860). GSC 69017 (NMC 19741, 19744, 19747, 19750, 19752, 19757, 19759). GSC 81052 (NMC 19749, 19751, 19753, 19755, 19758, 19761, 21484). GSC 81053 (NMC 19742-19743, 19745, 19748, 19754, 19756, 19760). GSC 81057 (NMC 19746).

*Description.* Dimensions of dorsal shield:

	Range (mm)	Average (mm)	Number measured
Median length	36.0-42.0	38.0	10
Maximum width	23.0-31.0	26.0	7
Orbital width	13.0-17.0	15.0	7
Orbital length	5.0- 8.5	6.4	9
Pineal length	8.0-11.0	9.5	6
Postbranchial length	12.0-14.0	13.0	4
	Range	Average	Number measured
Width ratio	0.55-0.74	0.67	7
Orbital width ratio	0.36-0.41	0.38	5
Orbital length ratio	0.15-0.19	0.17	7
Pineal length ratio	0.24-0.30	0.26	5
Postbranchial length ratio	0.31-0.35	0.33	4

The dorsal shield is constricted anterior to the deep orbital notches; the rostrum is commonly rounded, but may have a very slight median convexity. The lateral margins of the shield are convex, the branchial notches conspicuous and the postbranchial lobes well developed (Pl. 10, fig. 1). The posterior margin of the shield terminates in a median lobe (Pl. 10, fig. 3); the maxillary brim is well developed (text-fig. 25).

Ornamentation is of dentine ridges with a density of seven to eight per mm. The pattern is largely longitudinal, but may slightly fan out on the rostrum (Pl. 10, fig. 1); on the extreme anterior part of the rostrum, ridges are commonly subdivided into short lengths and tubercles. The pineal macula is conspicuous.

Dimensions of ventral shield:

	Range	Average	Number measured
Median length	30.0 mm	30.0 mm	1
Maximum width	18.0-22.0 mm	20.3 mm	3
Width ratio	0.6	0.6	1

The ventral shield has a slightly concave anterior margin, bordered anteriorly by an unornamented brim (Pl. 10, fig. 4). The shield is narrowest at its anterior margin, widening to a maximum width half-way along its length and tapering only slightly to the posterior end. The median lobe of the posterior margin of the ventral shield is of similar proportions to that of the dorsal.

The anterior part of the branchial plate is preserved in NMC 19860 (Pl. 10, fig. 4; text-fig. 25); ridges are longitudinal dorsally and oblique ventrally. The antero-dorsal margin has an unornamented brim. In the same specimen, which is preserved in ventral aspect, a plate is interposed between the anterior margin of the ventral shield and the maxillary brim of the dorsal shield (Pl. 10, fig. 4; text-fig. 25). Its width, 7 mm, is almost equal to the width of the anterior margin of the ventral shield; its length is 2 mm. Overlapped posteriorly by the anterior margin of the ventral shield, it lies adjacent to the anterior margin of the branchial plate. Its anterior margin, which is slightly convex, appears to be abraded. The lateral margins are

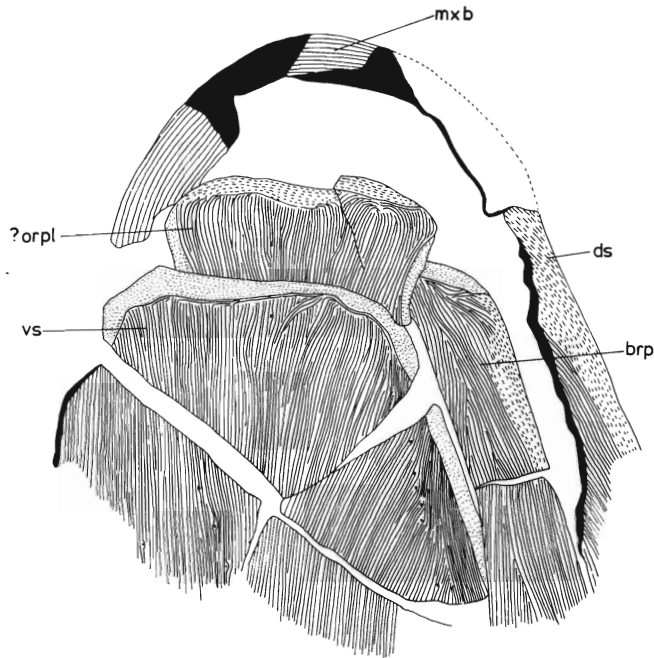

TEXT-FIG. 25. *Poraspis* cf. *P. polaris* Kiaer, oral region (NMC 19860);  $\times 3.75$ . *brp*, branchial plate; *ds*, dorsal shield; *mxb*, median brim; *?orpl*, ?oral plate; *vs*, ventral shield.

concave and have narrow, unornamented brims; the plate has an ornament of dentine ridges, which are transverse anteriorly and longitudinal posteriorly (Pl. 10, fig. 2).

*Remarks.* The greater length in the rostra found in two measurable specimens from GSC 69014 (NMC 13219 and 13220), as reflected in their larger orbital and pineal length ratios, seem an insufficient basis for establishing a new species; the specimens are otherwise similar to the rest of the material and to *Poraspis polaris*.

The specimens vary both in the pattern of dentine ridges on the rostrum and in general dimensions and proportions. Kiaer and Heintz (1935) recognized ornamental variation in *P. polaris* from Vestspitsbergen; they considered forms of different width

(the *angusta* and *lata* forms) to represent the different sexes. Although there is insufficient material for a statistical analysis, specimens from the District of Mackenzie seem to show continuous variation in width, related to the degree of crushing. Denison (1964, p. 406) suggested that this was also true of the Vestspitsbergen fossils.

If the single plate anterior to the ventral shield is an oral plate, as its abraded anterior margin suggests, it is unlike the oral apparatus previously described in the Cyathaspididae; *Anglaspis*, for example, has several small oral plates (Heintz 1962). The single plate of *P. polaris* may have been used as a scoop.

*Biostratigraphic significance.* *P. polaris*, originally described from the Red Bay Group of Vestspitsbergen (Kiaer and Heintz 1935), occurs in the *primaeva*, *polaris*, and *Anglaspis* horizons of the Fraenkelryggen Formation. The *primaeva* horizon is equivalent to the lowest Dittonian of Britain (Dineley 1967; Ørvig 1969a) and therefore to the Gedinnian (see Table below); *P. polaris* in Vestspitsbergen is confined to the Early Gedinnian.

?*Poraspis* sp. indet.

Plate 10, fig. 6

*Material.* NMC 19645, antero-lateral fragment of a dorsal shield.

*Locality.* GSC 69014.

*Description.* The dorsal shield, which is of moderate proportions, lacks epitegal subdivisions. The orbital notches are shallow and rather posteriorly placed; the rostrum narrows slightly toward their anterior ends (Pl. 10, fig. 6). The shield is extremely flattened. Ornamentation is of dentine ridges with a density of 7.5 per mm; these have a longitudinal arrangement, except on the rostral margin. On the rostral margin, ridges are broader than posteriorly, and have a transverse arrangement. The pineal macula is conspicuous, as are the pores of the lateral line system.

*Remarks.* This specimen can be assigned to the subfamily Poraspidinae. The conspicuous lateral line pores, pattern and density of ridges, and posterior position of orbit suggest *Poraspis*, but the absence of the posterior part of the shield makes further identification impossible.

*Biostratigraphic significance of Poraspis.* Apart from a dubious Late Silurian occurrence in Arctic Canada (Broad 1968), *Poraspis* appears to be restricted to the Early

EXPLANATION OF PLATE 10

Figs. 1-4. *Poraspis* cf. *P. polaris* Kiaer. 1, dorsal shield (NMC 13220),  $\times 2$ . 2, dorsal shield (NMC 13219),  $\times 2$ . 3, ventral shield (NMC 13211),  $\times 2$ . 4, articulated dorsal and ventral shields with ?oral and branchial plates (NMC 19860),  $\times 2$  (see text-fig. 25).

Fig. 5. *Ariaspis* cf. *A. ornata* Denison. Incomplete dorsal shield (NMC 13767),  $\times 2$ .

Fig. 6. ?*Poraspis* sp. indet. Incomplete dorsal shield (NMC 19645),  $\times 2$ .

Fig. 7. Cyathaspidinae indet., Type 2. Incomplete dorsal shield (NMC 19774),  $\times 2$ .

Figs. 8, 9. Poraspidinae indet. 8, Type 2, incomplete dorsal shield (NMC 19776),  $\times 2$ . 9, Type 1, incomplete dorsal shield (NMC 21428),  $\times 2$ .

Figs. 10, 11. Cyathaspididae indet. 10, Type 1, incomplete dorsal shield (NMC 19770),  $\times 2$ . 11, Type 2, incomplete dorsal shield (NMC 21427),  $\times 2$ .

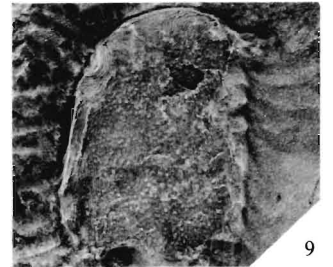
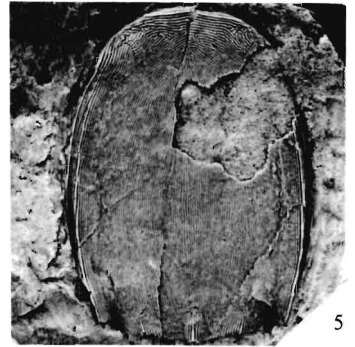

Devonian. It occurs in the Late Downtonian, Early and Middle Dittonian of Britain, and in equivalent strata in Vestspitsbergen; several species occur in the Dittonian Chortkov Horizon and Old Red Group of Podolia (see Denison 1964).

### Genus ARIASPIS Denison, 1963

- Synonymy.* 1963 *Ariaspis* new genus; Denison.  
 1964 *Ariaspis* Denison; Denison.  
 1964 *Ariaspis* Denison; Stensiö.  
 1973 *Ariaspis* Denison; Novitskaya.

*Diagnosis* (after Denison 1964). Dorsal shield broad and weakly vaulted. Median rostral process lacking but pre-orbital processes well developed. Narrow, downwardly directed lateral laminae extend from orbits to branchial opening and are separated from rest of shield by sharp angulations. Postbranchial lobes lacking; posterolateral corners of shield ending in small point. Posterior edge of dorsal shield transverse but for incorporated scale. Epitega not distinguishable.

*Type species.* *Ariaspis ornata* Denison.

#### *Ariaspis* cf. *A. ornata* Denison

Plate 10, fig. 5; text-fig. 26

*Material.* NMC 13767, incomplete dorsal shield.

*Locality.* CS YA20, Horizon 16F.

*Description.* Dimensions of dorsal shield:

	Median length 22 mm		
Maximum width	16 mm	Width ratio	0.73
Pineal length	6 mm	Pineal length ratio	0.27
Orbital length	2 mm	Orbital length ratio	0.14
Orbital width	12 mm	Orbital width ratio	0.55

The well-preserved shield is small, broad, and only slightly vaulted. Narrow (less than 1 mm wide), downwardly directed lateral laminae extend from behind the shallow orbital notches to within 3 mm of the postero-lateral tips of the shield (Pl. 10, fig. 5). They are widest at mid-length, narrowing gradually to the rear. Posterior to the lateral laminae, the lateral margins of the shield form minute alae, the postero-lateral corners of the shield ending in sharp points. The rostral margin is almost transverse and the pre-orbital process slightly developed. The pineal region of the shield is not preserved, but the internal mould of the pineal pit is anteriorly situated.

Ornamentation is of dentine ridges, which are narrow (7.5–8.0 per mm) and sharp-crested posteriorly, but wider (five per mm) and smooth-crested anteriorly. Several ridges are arranged parallel to the rostral margin, but the rest are longitudinal in the mid-line of the shield, parallel to the lateral margin laterally, and convergent anteriorly (text-fig. 26). On the rostrum, medial to the pre-orbital processes, are small areas of irregular ridges which are commonly curved around prominent lateral line pores (Pl. 10, fig. 5). The posterior margin of the shield is slightly convex, with a small median lobe formed by the posterior margin of a scale-like unit (Pl. 10, fig. 5). Wide,

TEXT-FIG. 26. *Ariaspis* cf. *A. ornata* Denison, dorsal shield (NMC 13767);  $\times 3.75$ . *lbr*, lateral brim; *or*, orbit; *pa*, pineal area; *scu*, scale-like unit.

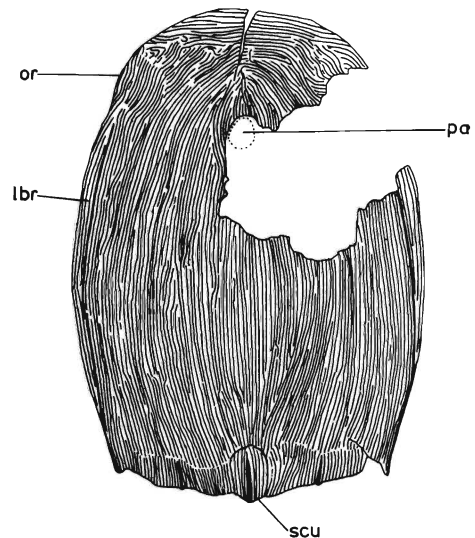

lateral scale-like areas are demarcated by discontinuity of dentine ridges; the median longitudinal ridge of the lateral and median scale-like areas are higher and slightly wider than the rest of the ornamentation.

*Remarks.* This specimen closely resembles *A. ornata* from the Beaver River area (Denison 1963); its dimensions are like those of the holotype.

It differs from the holotype in details of the posterior margin of the shield; the median scale-like area, which was interpreted by Denison (1963, 1964) as a fused dorsal ridge scale, is less obviously demarcated from the rest of the dorsal shield than in the holotype, and has an elevated median ridge. One cannot determine whether these differences arise from intraspecific variation, since the holotype of *A. ornata* is the only other specimen. As a result of crushing, the rostral margin of the specimen is more transverse, and the pre-orbital processes smaller, than in the holotype.

*Biostratigraphic significance.* The fauna containing *A. ornata* Denison is from the Beaver River area of south-eastern Yukon; its age is discussed elsewhere (see p. 187).

#### Genus HOMALASPIDELLA Strand, 1934

*Synonymy.* Prior to 1964, see Denison (1964).

1964 *Homalaspidella* Strand; Stensiö.

1973 *Homalaspidella* Strand; Novitskaya.

*Diagnosis* (after Denison 1964). Shields rather narrow, but of uniform width and only slightly vaulted. Rostrum broadly rounded, lacking median lobe; pre-orbital processes and orbital notches slightly developed, pre-orbital length short. Dentine ridges moderately wide and flat-topped, epitega little or not at all indicated. Ridge pattern longitudinal, but for band of ridges parallel to anterior and lateral margins. Dorsal transverse commissures of lateral line system poorly developed.

*Type species.* *Homalaspis nitida* Kiaer.

*Homalaspidella* cf. *H. borealis* Denison

Plate 7, fig. 9

*Material.* NMC 19765, incomplete dorsal shield associated with several scales.

*Locality.* GSC 81050.

*Description.* The dorsal shield, which is not divided into epitega, is 32 mm long. Its anterior margin is transverse, its posterior margin drawn out to a slight median point. The orbital notches are shallow and rather anteriorly placed (orbital length ratio 0.13); the preorbital processes are only slightly developed. Coarse dentine ridges with a density of 4.0–4.5 per mm give a simple pattern, lacking epitega. Several ridges are arranged transversely on the rostral margin, the rest of the ornamentation being largely longitudinal with irregularities (Pl. 7, fig. 9). The pineal macula is conspicuous and the supra-orbital lateral line canals are marked by the alignment of pores.

The body scales, which are associated with the headshield, include paired lateral scales and a ridge scale (Pl. 7, fig. 9). The dorso-lateral and ventro-lateral scales are of equal size, as in *Dinaspidella* and *Nahanniaspis* gen. nov.; they are of similar shape to the dorso-lateral scales of *Poraspis* (Kiaer and Heintz 1935). One or two transverse ridges are arranged parallel to the anterior margin of the scales, the rest of the ridges being longitudinal; ridges on the body scales are coarser than on the dorsal shield, having a density of 3.0–3.5 per mm. The single dorsal ridge scale is short, broad, and symmetrical, with longitudinal ridges.

*Remarks.* Despite close resemblance to *Homalaspidella borealis*, there are several minor differences between this specimen and Denison's material (1963, 1964) from the Beaver River area. The present dorsal shield is slightly longer and the orbital length ratio slightly greater; dentine ridges are coarser and a pineal macula is readily distinguishable. Although Denison (1964) described *H. borealis* as lacking a pineal macula, photographs (Denison 1963) and a plaster cast of the holotype clearly reveal one.

*Biostratigraphic significance.* The type locality of *H. borealis* is in the Beaver River area of south-eastern Yukon; its age is discussed below (see p. 197).

*?Homalaspidella* sp. indet., Types 1, 2, 3, and 4

Plate 7, figs. 6–8, 13

*Material.* Nine poorly preserved, incomplete dorsal shields: NMC 19771, 19775, 19777–19780, 21424, 21426, 21429. Five incomplete and poorly preserved ventral shields: NMC 21503–21507.

*Localities.* GSC 58497 (NMC 21426). GSC 81050 (all other specimens).

*Description and remarks.* The dorsal shields resemble *Homalaspidella* Strand in lacking epitega, having broadly rounded rostra, poorly developed pre-orbital processes, and shallow orbital notches. All are of moderate proportions and have dentine ridges with a density of four to five per mm. The considerable variety of rostral ornamentation has been used to group the dorsal shields into four types. Five ventral shields

from GSC 81050 have transverse ridges anteriorly and longitudinal ridges posteriorly; they are probably also referable to *Homalaspidella*.

*Type 1: Material.* NMC 19777, 19779 (Pl. 7, fig. 8), 21429.

*Description.* The anterior rostral margin is bordered by several transverse ridges; more posterior rostral ridges are longitudinal or irregular. The supra-orbital lateral line canals are marked by a row of small tubercles, some of which are pierced by lateral line pores.

*Type 2: Material.* NMC 19775, 21424, 21426 (Pl. 7, fig. 6).

*Description.* The anterior and antero-lateral margins of the rostrum are bordered by ridges arranged parallel to the margin of the shield. Ridges converge anterior to the conspicuous pineal macula, forming a broad curve around the anterior part of the shield.

*Type 3: Material.* NMC 19778 (Pl. 7, fig. 13).

*Description.* Anterior to the pineal macula, ridges are transverse anteriorly and divided into small, rhomboidal tubercles posteriorly. Behind the pineal macula, ridges are long and longitudinal.

*Type 4: Material.* NMC 19771 (Pl. 7, fig. 7), 19780.

*Description.* Ridges are transverse on the anterior margin of the rostrum, but irregular between this and the pineal macula. Ridges are commonly curved and subdivided into short lengths.

*Biostratigraphic significance of Homalaspidella.* *Homalaspidella* Strand occurs in the Late Silurian of Western Canada and in the Early Devonian of Vestspitsbergen (see Denison 1964). Denison (1964, p. 464) has suggested that the European and Canadian species might be unrelated, their similarities being a result of parallel evolution.

#### Poraspidinae indet., Type 1

Plate 10, fig. 9

*Material.* NMC 21428, incomplete dorsal shield.

*Locality.* GSC 58497.

*Description.* The estimated width of the shield is 14 mm. The rostrum is broadly rounded and not constricted anterior to the deep orbital notches; pre-orbital processes are only slightly developed. Dentine ridges with a density of seven per mm, are largely long and longitudinal except for an area of ridges in a fan-like pattern and transverse ridges on the rostrum. The pores of the supra-orbital lateral line canal are conspicuous.

*Remarks.* The lack of epitega and the predominantly longitudinal ridge pattern indicate poraspidinid affinities.

#### Poraspidinae indet., Type 2

Plate 10, fig. 8

*Material.* NMC 19776, incomplete dorsal shield.

*Locality.* GSC 69017.



*Description.* The shield, 16 mm wide and over 20 mm long, is not divided into epitega. The orbital notches are shallow and the pre-orbital processes are only slightly developed; a median rostral process is absent. Ornament is of long and short dentine ridges of uniform height, with a density of 5.5–6.0 per mm. On the anterior part of the shield, short ridges radiate from the pineal macula (Pl. 10, fig. 8); toward the rostral margin they subdivide into short lengths and tubercles, being replaced at the margin by several short, transverse ridges. The position of the supra-orbital lateral line canals is marked by the presence of a row of tubercles, many of which are pierced by single lateral line pores.

*Remarks.* The lack of epitega and scale components indicate poraspidinid affinities. Poor preservation prevents assignment to a smaller taxon.

#### Subfamily IRREGULAREASPIDINAE Denison, 1964

*Diagnosis* (after Denison 1964, supplemented). Dorsal shield broad, lacking scale components and not divided into epitega; orbits and pineal organ posteriorly placed. Lateral line system simple or complex; postbranchial lobes present in some genera. Ventral shield with lateral margins indented for reception of sub-branchial scales. Dorso-lateral and ventro-lateral body scales of similar size; dermal skeleton thin. Ornamentation of very narrow dentine ridges, commonly arranged in irregular whorls.

*Genera.* *Dinaspidella* Strand, *Irregulareaspis* Zych, *Nahanniaspis* gen. nov.

#### Genus DINASPIDELLA Strand, 1934

*Synonymy.* Prior to 1964, see Denison (1964).

1964 *Dinaspidella* Strand; Stensiö.

*Diagnosis* (after Denison 1964, supplemented). Dorsal shield of rather uniform width, without epitega and with posteriorly situated pineal organ. Median rostral process absent; postbranchial lobes well developed. Rostral ornament of fine, transverse ridges anteriorly and irregular whorls posteriorly; rest of dorsal ridge pattern longitudinal with irregularities. Ventral shield with lateral margins incised for reception of sub-branchial scales; posterior margin of dorsal and ventral shields with median point. Lateral line system of dorsal shield with transverse commissure anterior to pineal organ with supra-orbital canals continuous with median dorsal canal. Dorso-lateral and ventro-lateral body scales of similar size.

*Type species.* *Dinaspis robusta* Kiaer (*nomen nudum*).

*Dinaspidella* sp. indet.

Plates 11, 12; text-figs. 27–30

*Material.* Forty-four isolated dorsal shields: NMC 13216, 19500–19501, 19503–19505, 19509–19510, 19512–19513, 19515–19516, 19518–19519, 19521–19522, 19524–19525, 19527, 19532–19534, 19537, 19539–19545, 19549, 19555, 19577–19578, 19580, 19597, 19605, 19608, 19644, 19646, 19654, 19656, 19666.

Fourteen isolated ventral shields: NMC 13215, 19550, 19552, 19554, 19557–19558, 19560, 19568–19569, 19585–19587, 19601, 19606.

Twenty-eight articulated specimens (largely scales): NMC 12883, 13054, 13134, 13187–13189, 13196–

13200, 13209, 19556, 19561, 19566–19567, 19570, 19572–19573, 19581, 19588, 19595, 19603, 19612, 19614, 19616, 19619, 19647, 19648, 21500–21501.

*Localities.* GSC 81051 (NMC 13216, 19505, 19509, 19542, 19544, 19552, 19554, 19601. GSC 69014 (all other material).

*Description.* (i) *Dorsal shield.* Dimensions:

	Range (mm)	Average (mm)	Number measured
Median length	33.0–43.0	38.0	26
Maximum width	19.0–25.0	21.0	21
Orbital width	14.5–19.5	17.0	35
Orbital length	7.0–11.0	9.0	39
Pineal length	9.5–13.0	11.0	32
Postbranchial length	11.0–16.5	14.0	15
	Range	Average	Number measured
Width ratio	0.48–0.65	0.64	12
Orbital width ratio	0.39–0.54	0.44	20
Orbital length ratio	0.20–0.28	0.24	21
Pineal length ratio	0.26–0.33	0.29	20
Postbranchial length ratio	0.28–0.40	0.36	15

The dorsal shield is of rather uniform width and has a broadly rounded rostral margin; in rare, uncrushed specimens (e.g. NMC 19580, Pl. 11, fig. 6), the pre-orbital region is slightly constricted. The orbital notches are shallow and the pineal macula is indistinct; both occupy relatively posterior positions. Postbranchial lobes with abrupt anterior margins are present behind the branchial notches; the posterior margin of the shield may be drawn out to a point (NMC 19532, Pl. 11, fig. 5) or terminate in a small, median lobe (NMC 19587, Pl. 11, fig. 4). On the underside of the dorsal shield, a narrow lateral brim extends from the orbit to the branchial notch; the maxillary brim is narrow but the pre-orbital processes are well developed.

Ornamentation is of dentine ridges, which are smooth-crested and have a density of ten to twelve per mm. On the rostrum, ridges are transverse or broadly fan out anteriorly but form a whorl posteriorly; on the rest of the shield, ridges are sinuously longitudinal, with irregularities, particularly in the region of the lateral line canals (Pl. 11, fig. 1). On the underside of the dorsal shield, ridges are almost transverse on the maxillary brim and longitudinal on the lateral brim. In many specimens, differences in the reflective property of the superficial layer of the shield reveal a number of concentric ridges (text-fig. 41); their significance is discussed elsewhere (p. 105).

(ii) *Ventral shield.* Dimensions:

	Range	Average	Number measured
Median length	30–40 mm	35 mm	7
Maximum width	20–28 mm	23 mm	7
Width ratio	0.58–0.83	0.67	7

The lateral margins of the ventral shield are deeply incised for the reception of the sub-branchial scales; the antero-lateral corners are notched and the anterior margin is slightly, but smoothly, concave. The shield is narrowest near its anterior margin

(text-fig. 27), broadening posteriorly; the posterior margin of the shield is drawn out to a median point. The anterior margin has a narrow (0.25 mm), unornamented brim, which does not appear to extend around to the lateral margins (Pl. 11, fig. 7). In specimens which are not completely crushed, the ventral shield is more vaulted posteriorly than anteriorly.

Ornamentation, like that of the dorsal shield, is of smooth-crested dentine ridges with a density of ten to twelve per mm. The pattern is irregularly longitudinal over the posterior part of the shield but may be convergent, transverse, or irregularly whorled toward the anterior (text-fig. 27). Concentric markings, caused by differences in the reflective property of the superficial layer, are less distinct than on the dorsal shield.

(iii) *Branchial plate*. The branchial plate, which is preserved in NMC 19566 (Pl. 12, fig. 4; text-fig. 28) and NMC 12883 (Pl. 11, fig. 8), is long (16 mm) and narrow (2.5 mm), with a branchial notch three-quarters along its length. Anterior to the branchial notch, the dorsal and ventral margins of the plate are parallel, the anterior margin being formed by an unornamented brim facing antero-dorsally. Posterior to the branchial notch, the plate expands to form a dorsal lobe with an unornamented dorsal brim. Ornamentation is of fine, almost longitudinal, dentine ridges.

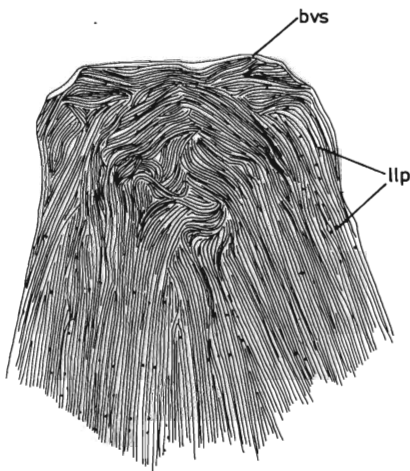

TEXT-FIG. 27. *Dinaspidella* sp. indet., ornamentation of anterior part of ventral shield (NMC 19569);  $\times 3.75$ . *bvs*, unornamented lateral brim of ventral shield; *llp*, lateral line pores.

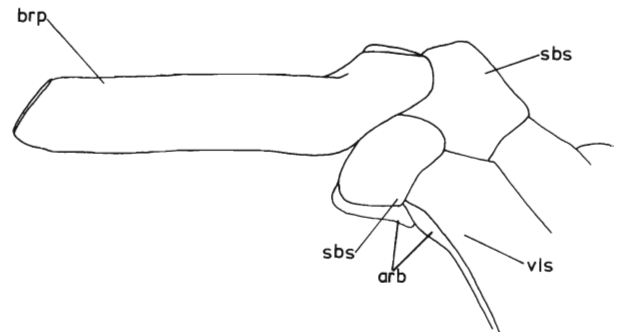

TEXT-FIG. 28. *Dinaspidella* sp. indet., branchial plate and sub-branchial scales (NMC 19566);  $\times 5$ . *arb*, antero-dorsal unornamented brim; *brp*, branchial plate; *sbs*, sub-branchial scale; *vls*, ventro-lateral scale.

#### EXPLANATION OF PLATE 11

Figs. 1-8. *Dinaspidella* sp. indet. 1, incomplete dorsal shield (NMC 19544),  $\times 2$ . 2, incomplete dorsal shield with distinct lateral line pores (NMC 19500),  $\times 2$  (see text-fig. 30A). 3, incomplete dorsal shield, etched to show lateral line canals (NMC 19521),  $\times 2$  (see text-fig. 30B). 4, incomplete ventral shield (NMC 19587),  $\times 2$ . 5, crushed dorsal shield (NMC 19532),  $\times 2$ . 6, uncrushed dorsal shield (NMC 19580),  $\times 2$ . 7, incomplete ventral shield (NMC 19569),  $\times 2$  (see text-fig. 27). 8, dorsal shield associated with branchial plate, dorso-lateral and dorsal ridge scales (NMC 12883),  $\times 2$ .

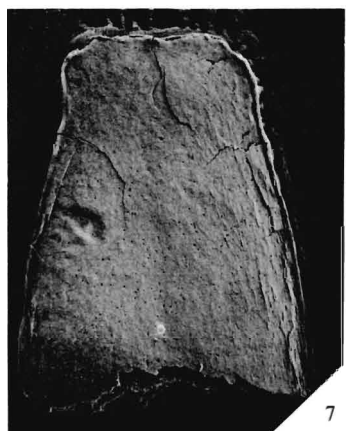
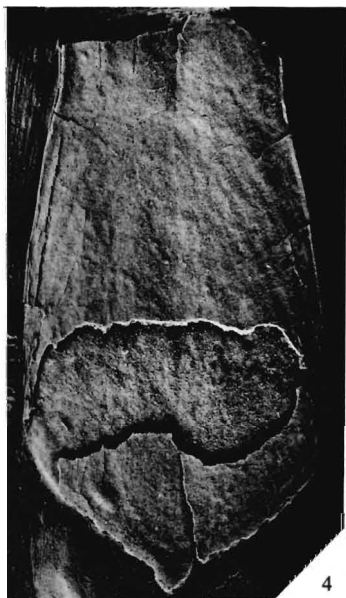

DINELEY and LOEFFLER, *Dinaspidella* sp. indet.

(iv) *Sub-branchial scales*. Two sub-branchial scales are associated with the branchial plate in NMC 19566 (Pl. 12, fig. 4; text-fig. 28). The more posterior of the two scales is the larger; it is overlapped anteriorly by the posterior margin of the other scale, the posterior lobe of the branchial plate and a ventro-lateral scale. The anterior sub-branchial scale is overlapped dorsally by the ventral margin of the posterior lobe of the branchial plate. These scales are regarded as equivalent to the most posterior scales of the sub-branchial scale series in *Nahanniaspis mackenziei*. The similar shapes of the ventral shields of the latter species and of *Dinaspidella* sp. indet. suggests that a series of scales was also present in that genus.

(v) *Posterior body and caudal fin*. Behind the headshield, the body and tail are covered by discrete scales (Pl. 12, figs. 1, 2; text-fig. 29) with an arrangement closely resembling

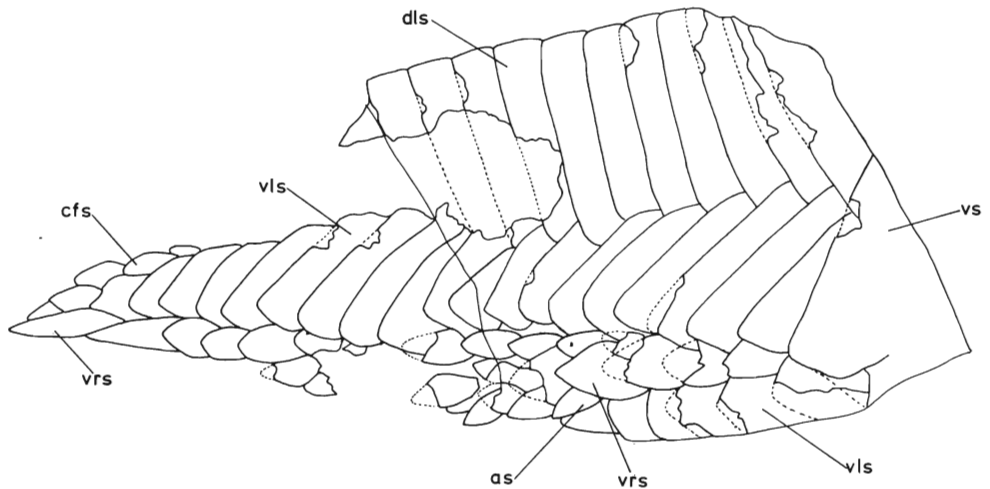

TEXT-FIG. 29. *Dinaspidella* sp. indet., articulated trunk scales (NMC 13134);  $\times 2$ . *as*, 'additional' scale; *cfs*, caudal fin scale; *dls*, dorso-lateral scale; *vls*, ventro-lateral scale; *vrs*, ventral ridge scale; *vs*, ventral shield.

that of *N. mackenziei*. The dorso-lateral and ventro-lateral scales are of almost equal size and symmetrical 'additional' scales occur between the ventral and the ventro-lateral scales. Each scale is ornamented with narrow ridges (eleven to twelve per mm), which are smooth-crested and have a similar arrangement to those in *N. mackenziei* (text-fig. 36). Each ring of scales overlaps the ring behind and comprises a pair of dorso-lateral scales, a pair of ventro-lateral scales, a dorsal and a ventral ridge scale, and a variable number of 'additional' scales.

The dorso-lateral and ventro-lateral scales are of similar size and shape; when isolated, they are indistinguishable. Together, the dorso-lateral and ventro-lateral

#### EXPLANATION OF PLATE 12

Figs. 1-4. *Dinaspidella* sp. indet. 1, associated body scales (NMC 13134),  $\times 2.5$  (see text-fig. 29). 2, associated body scales and caudal region (NMC 13189),  $\times 2.5$ . 3, caudal fin, preserved partly as an external mould (NMC 19572),  $\times 1.5$ . 4, associated branchial plate, sub-branchial, ventro-lateral, additional, and ventral ridge scales (NMC 19566),  $\times 1.5$  (see text-fig. 28).

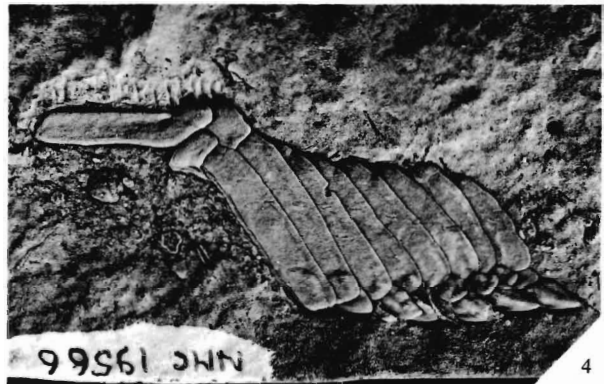
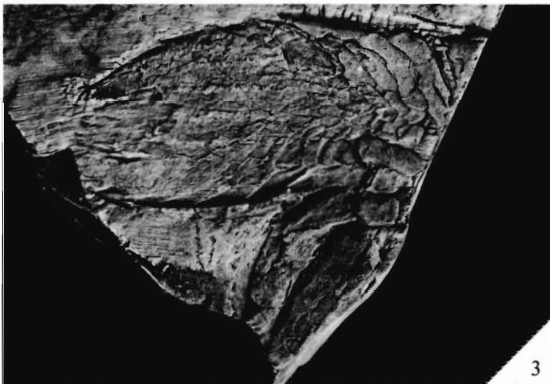
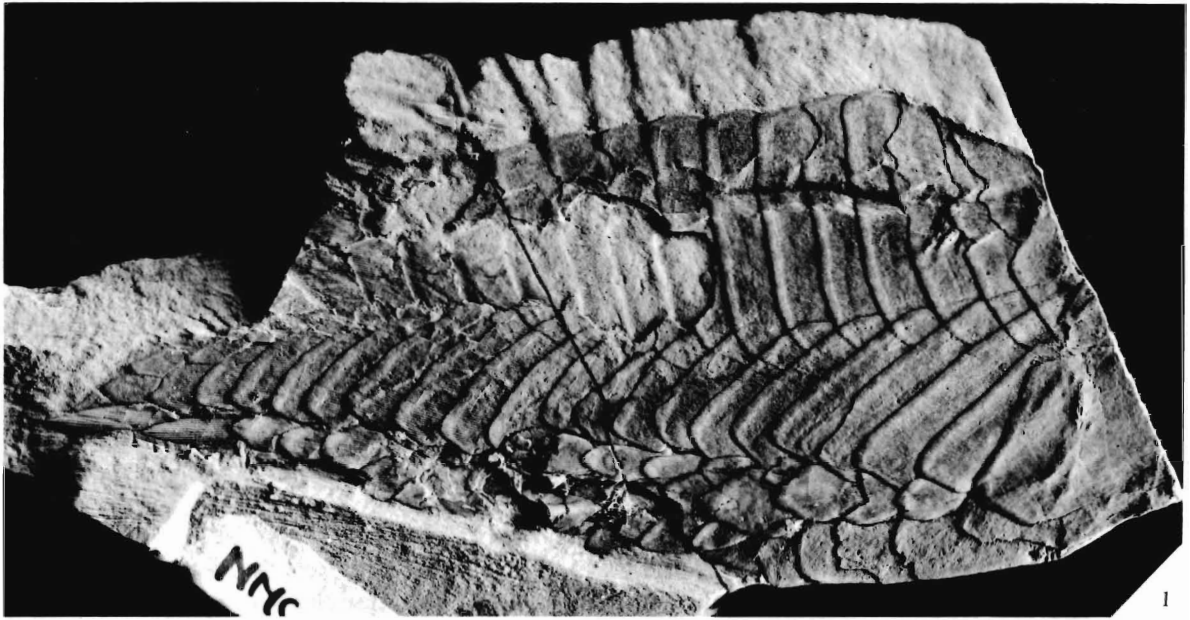

DINELEY and LOEFFLER, *Dinaspidella* sp. indet.

scales of a particular ring are arranged in a forward-pointing V (Pl. 12, figs. 1, 2). The anterior margin of each of the lateral scales is slightly concave, the posterior margin convex; the antero-lateral margins are separated from the postero-lateral by a slight bend, the anterior and antero-lateral margins being bordered by an unornamented brim which extends antero-laterally as a triangular process for articulation. Lateral scales are typically 10–15 mm high and 3–4 mm wide. The dorsal and ventral ridge scales are symmetrical; although short (5–6 mm) and broad (3–4 mm) anteriorly, they become long (8 mm) and narrow (2 mm) toward the caudal region (Pl. 12, fig. 2). The more anterior dorsal ridge scales commonly have an elevated median portion. The 'additional' scales are generally small (4 mm in diameter), flat, and oval. In a single scale ring, 'additional' scales may be absent or there may be one or two on either side of the ventral ridge scale (text-fig. 29). Although 'additional' scales may be present in the most anterior scale ring of some specimens, they are not found forward of the fourth scale ring of others. 'Additional' scales are present behind the twelfth scale ring in any specimen.

The number of scale rings in the body region varies from ten to twelve, the caudal region being defined as beginning where the large lateral scales are replaced by small lozenge-shaped caudal scales. An anal region is not distinguishable in any of the specimens, all of which are incomplete in the region of the tenth to twelfth scale rings.

The caudal fin is not preserved entire but is clearly heterocercal. The dorsal and ventral margins are stiffened by very elongated, narrow, ridge scales (the 'fulcral' scales of Kiaer and Heintz 1935); the lateral cover is of small (1–2 mm diameter), lozenge-shaped scales (Pl. 12, fig. 2). Even in the most complete caudal fin (Pl. 12, fig. 3), it is not possible to determine if the larger lobe was dorsal or ventral.

The body scales are ornamented with dentine ridges, which are largely longitudinal but commonly give way to a border of transverse ridges on the anterior part of each scale. When the scales are articulated, the unornamented brim and the border of transverse ridges are completely overlapped by the posterior part of the preceding scale (Pl. 12, figs. 1, 2, and 4). The ridges of the dorso-lateral and ventro-lateral scales are locally interrupted by small lateral line pores.

(vi) *Lateral line system.* On both dorsal and ventral shields, small and numerous lateral line pores are so scattered that tracing of the canal system by pores alone is difficult (text-fig. 30). A dorsal shield (NMC 19521) etched in 10% hydrochloric acid revealed that, although pores are numerous and scattered, the lateral line canal system is a simple network (text-fig. 30). The supra-orbital canals are continuous with the median dorsal canals; several posterior transverse commissures link the discontinuous lateral dorsal canals with the median dorsal canals. Anteriorly, a transverse, supra-orbital commissure links the lateral dorsal canal with the supra-orbital canal and continues medially as a pre-pineal transverse commissure. Owing to lack of suitable specimens, a ventral shield was not etched in the same way; distribution of pores on the ventral shield (text-fig. 27) suggests a relatively simple network.

Lateral line pores at the anterior end of the branchial plate may indicate a connection between the dorsal and ventral systems. Pores are present on the dorso-lateral and ventro-lateral scales, but are rare. On the ventro-lateral scales, pores are commonly rather dorsally situated, but on the dorso-lateral scales they may be dorsal

or ventral. There are seldom more than two pores per scale, the majority of scales having no pores.

*Remarks.* This material is referred to *Dinaspidella* sp. indet. because of nomenclatorial difficulties. *Dinaspidella* is 'not available' nomenclatorially, because both of the specific names, *D. robusta* and *D. parvula*, are *nomina nuda*; they were merely listed by Kiaer (1932). (According to N. Heintz (pers. comm.), Obruchev had been working on this material shortly before his death; the late Professor A. Heintz similarly intended to re-examine it.)

*Dinaspidella* is very similar to *Irregulareaspis* in all but its lateral line system; Kiaer (1932) regarded *Dinaspidella* as the original stock from which *Irregulareaspis*

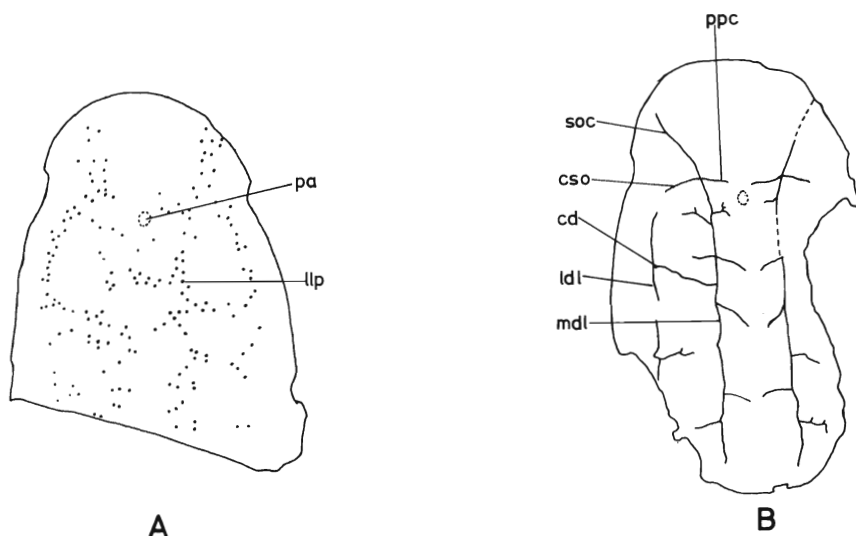

TEXT-FIG. 30. *Dinaspidella* sp. indet. A, distribution of lateral line pores on dorsal shield (NMC 19500);  $\times 1.875$ . B, lateral line canal system, drawn from etched dorsal shield (NMC 19521);  $\times 1.875$ . *cd*, dorsal transverse commissure; *cso*, transverse sub-orbital commissure; *ldl*, lateral dorsal canal; *llp*, lateral line pore; *mdl*, median dorsal canal; *pa*, pineal macula; *ppc*, pre-pineal canal; *soc*, supra-orbital canal.

had evolved. Both genera have uniformly broad shields with well-developed post-branchial lobes, ventral shields with incised lateral margins, ornamentation of very fine, whorled ridges, and particularly thin shields. The present material demonstrates that the squamation of *Dinaspidella* is similar to that of *Irregulareaspis* (Kiaer 1932, pl. 5); both have dorso-lateral and ventro-lateral scales of similar size.

There are also similarities between *Dinaspidella* and *Nahanniaspis mackenziei*. The latter species shares with *Dinaspidella* the uniformly broad shield, fine whorled ridges, thin dermal skeleton, posteriorly situated orbits and pineal organ, and simple lateral line system. *Dinaspidella*, *Irregulareaspis*, and *Nahanniaspis* are here united in the subfamily Irregulareaspidinae; although Denison (1964) included *Dikenaspis* in the same subfamily, it is proposed here that this be placed in the subfamily Cyathaspidinae (see p. 108).



*Biostratigraphic significance of Dinaspidella.* *D. robusta* (*nomen nudum*) and *D. parvula* (*nomen nudum*), occur in the Fraenkelyruggen Formation of the Red Bay Group of Vestspitsbergen (Kiaer 1932). Kiaer (1932, p. 18) regarded the genus as 'very characteristic of the upper portion of the Fraenkelyruggen group'.

Material compared with *Dinaspidella* has been recorded from approximately 20 m above the top of the Ronning Dolomite (i.e. within the Gossage Formation, Norris (1968)), west of Snake River in the northern Yukon, Denison (1964) and Dineley (1965). An early Devonian age was suggested for that fauna, which included indeterminate Poraspidinae, Cyathaspidinae, and a form which was identified as *Corvaspis* (see p. 197).

#### Genus NAHANNIASPIS gen. nov.

*Derivation of name.* From the South Nahanni River, which flows through the Mackenzie Mountains, and Greek *aspis* meaning shield.

*Diagnosis.* Dorsal shield small, of uniform width and without epitegal subdivisions; rostrum broadly rounded, orbital notches shallow and postbranchial lobes lacking; orbits and pineal organ posteriorly situated; posterior margin of shield drawn out. Ornamentation of narrow (eleven to thirteen per mm) dentine ridges, transverse and whorled on rostrum and irregularly longitudinal posteriorly. Ventral shield with irregularly concave lateral margins for reception of sub-branchial scales. Lateral line pattern of dorsal and ventral shields in form of simple network. Dorso-lateral and ventro-lateral body scales of similar size.

*Type species.* *N. mackenziei*.

#### *Nahanniaspis mackenziei* gen. et sp. nov.

Plates 13, 14; text-figs. 31–36, 38

*Derivation of name.* From Alexander Mackenzie, an early explorer of the Canadian North West.

*Diagnosis.* As for genus, the type species being the only species.

*Holotype.* NMC 19673, an almost complete, articulated specimen (Pl. 14, text-fig. 35).

*Paratypes.* NMC 13212 (Pl. 13, fig. 1), 19507 (Pl. 13, fig. 2), dorsal shields; NMC 19553 (Pl. 13, fig. 4), 19562 (Pl. 13, fig. 3), ventral shields; NMC 19651 (Pl. 13, fig. 9), articulated headshields and body scales, with branchial plate and sub-branchial scales.

*Other material.* Twenty-six dorsal shields: NMC 13213, 19502, 19506, 19508, 19511, 19514, 19517, 19520a, 19526, 19528–19531, 19535–19536, 19538, 19546–19548, 19559, 19579, 19659b, 19662b–d, 19762.

Eight isolated ventral shields: NMC 19520b, 19551, 19565, 19607, 19617–19618, 19662a, 19763.

Thirty-four articulated specimens (largely scales): NMC 13185, 13190–13195, 13201–13208, 13210, 19563–19564, 19571, 19574–19575, 19583–19584, 19604, 19609–19610, 19615, 19620, 19650, 19657.

Four blocks with isolated scales: NMC 13217, 19576, 19659a, 21499.

*Type locality.* GSC 69014 (all specimens listed above except those listed below under 'Other localities').

*Other localities.* GSC 81051 (NMC 13212, 19508, 19551, 19579, 19607, 19659a and b).

*Description. (i) Dorsal Shield. Dimensions:*

	Range (mm)	Average (mm)	Number measured
Median length	18.0-25.0	21.0	22
Maximum width	10.0-14.0	13.0	19
Orbital width	9.0-12.0	10.6	16
Orbital length	4.0-7.0	5.8	19
Pineal length	5.0-8.0	6.7	20
Postbranchial length	6.5-9.0	7.8	8

	Range	Average	Number measured
Width ratio	0.5-0.7	0.59	18
Orbital width ratio	0.4-0.6	0.45	15
Orbital length ratio	0.21-0.33	0.24	18
Pineal length ratio	0.30-0.33	0.31	18
Postbranchial length ratio	0.32-0.43	0.37	8

The dorsal shield is very flat; its rostral margin is broadly rounded, lateral margins slightly convex, and posterior margin drawn out to a median point (Pl. 13, figs. 1, 2, 6, 7; text-fig. 31). The rostrum is broadly rounded, lacks a median rostral process, and is not constricted in front of the orbits; on its undersurface are a narrow maxillary brim (Pl. 13, fig. 5) and moderately well-developed pre-orbital processes. The lateral margins of the shield are convex between the orbital and the branchial notches, the widest part of the shield being midway between these two points. Posterior to the branchial notches, the dorsal shield is slightly constricted, postbranchial lobes not being developed. A narrow lateral brim extends from the shallow orbital notch to the branchial notch, on the underside of the shield. A true pineal macula is not present, but the impression of the pineal body can commonly be seen occupying a rather posterior position, behind the inter-orbital line. Because this area is elevated, it is commonly abraded; dentine ridges tend to diverge from it (Pl. 13, fig. 1).

Dorsal ornamentation is of closely spaced, sharp-crested dentine ridges with a density of eleven to thirteen per mm. On the rostrum, their arrangement is transverse or fans out anteriorly and whorled posteriorly (Pl. 13, fig. 1); on the rest of the dorsal shield, the pattern is sinuously longitudinal with irregularities, particularly in the region of the lateral line canals (text-fig. 31). On the ventral surface of the dorsal shield, the lateral and maxillary brims and the pre-orbital processes bear an ornament of dentine ridges. The pattern is longitudinal on the lateral brim, almost transverse on the maxillary brim and parallel to the margins of the pre-orbital

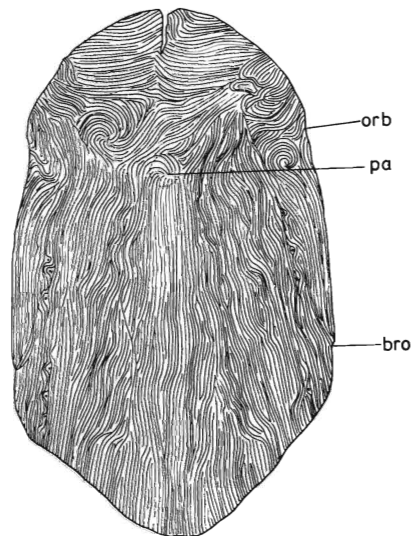

TEXT-FIG. 31. *Nahanniaspis mackenziei* gen. et sp. nov., dorsal shield (NMC 13212, paratype);  $\times 3.75$ . *bro*, branchial notch; *orb*, orbit; *pa*, pineal macula.

processes. Differences in the reflective property of the superficial layer of the shield show up as concentric markings, which may be growth lines (see p. 105 and text-fig. 38).

(ii) *Ventral shield*. Dimensions:

	Range	Average	Number measured
Median length	14-19 mm	16 mm	12
Maximum width	10-14 mm	12 mm	10
Width ratio	0.61-0.81	0.73	10

The anterior margin is irregularly concave and, in well-preserved specimens (e.g. NMC 19553, Pl. 13, fig. 4; text-fig. 32B), is indented by a series of notches, the most prominent of which is median. A narrow, unornamented brim extends from the notched antero-lateral corners of the shield across the anterior margin. The lateral margins of the shield are concave and irregularly indented, lacking an unornamented brim (Pl. 13, fig. 3). The shield is narrowest several millimetres behind its anterior margin, widening to the posterior end where the margin is drawn out to a median point.

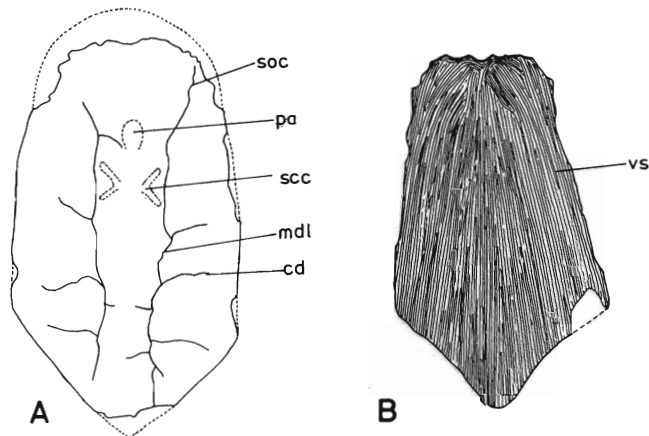

TEXT-FIG. 32. *Nahanniaspis mackenziei* gen. et sp. nov. A, lateral line canal system on dorsal shield (NMC 19659b);  $\times 3.75$ . B, ornamentation of ventral shield (NMC 19553, paratype);  $\times 3.75$ . *cd*, transverse commissure; *mdl*, medial dorsal canal; *pa*, pineal macula; *scc*, semicircular canal; *soc*, supra-orbital canal; *vs*, ventral shield.

#### EXPLANATION OF PLATE 13

Figs. 1-9. *Nahanniaspis mackenziei* gen. et sp. nov. 1, dorsal shield (NMC 13212, paratype),  $\times 2$  (see text-fig. 31). 2, incomplete dorsal shield (NMC 19507, paratype),  $\times 2$ . 3, ventral shield (NMC 19562, paratype),  $\times 2$ . 4, ventral shield (NMC 19553, paratype),  $\times 2$  (see text-fig. 32B). 5, sub-rostral surface, showing maxillary brim and pre-orbital process (NMC 19526),  $\times 3.5$ . 6, incomplete reversed dorsal shield, showing lateral line canals (NMC 19659b),  $\times 2$  (see text-fig. 32A). 7, incomplete dorsal shield (NMC 19528),  $\times 2$ . 8, incomplete ventral shield associated with body scales (NMC 13190),  $\times 2$ . 9, articulated headshields and body scales, with branchial plate and sub-branchial scales (preserved in ventral aspect) (NMC 19651, paratype),  $\times 4$  (see text-fig. 33).



1



2



3



4



5



6



7

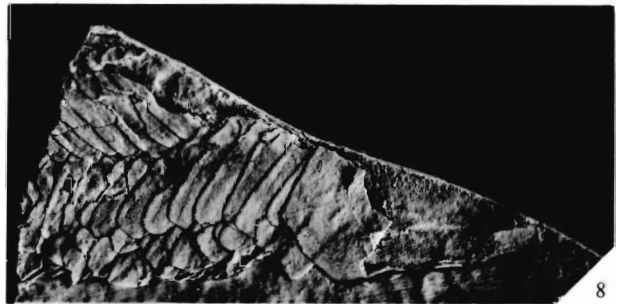

8

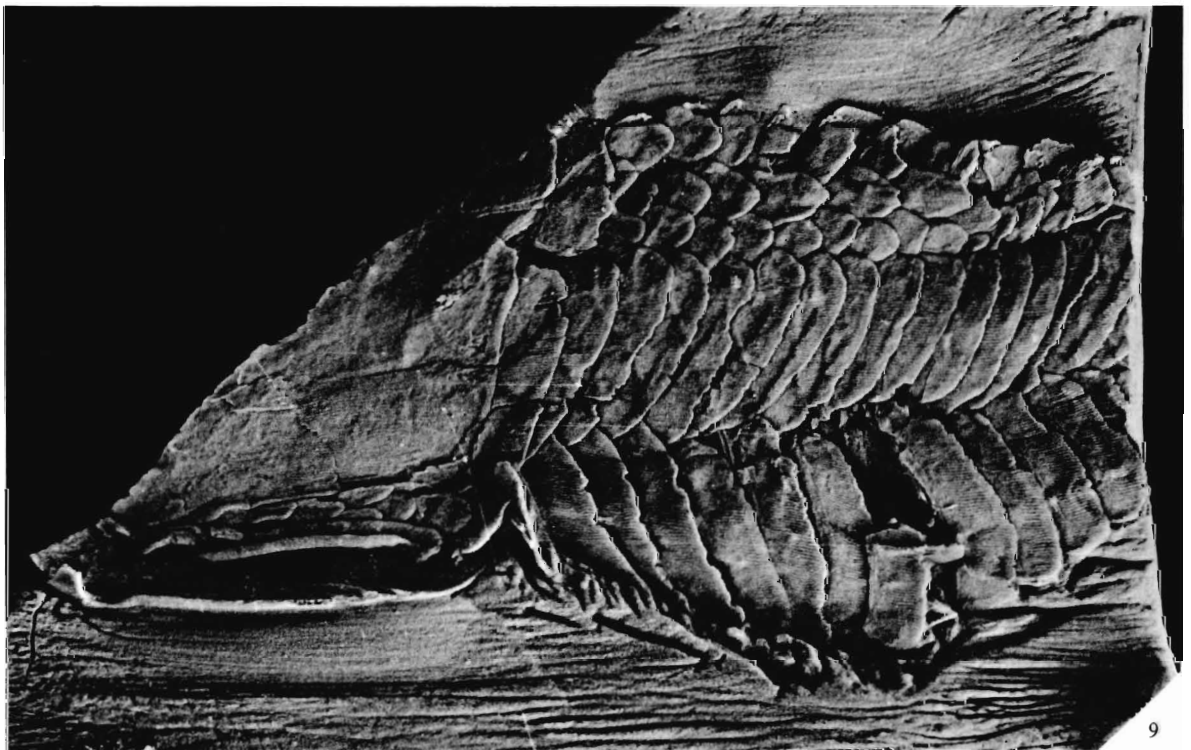

9

DINELEY and LOEFFLER, *Nahanniaspis mackenziei*

Ornamentation is of sharp-crested dentine ridges with a density of eleven to thirteen per mm. The pattern is largely longitudinal with irregularities and a tendency to anterior convergence (Pl. 13, fig. 3); in NMC 19553 (Pl. 13, fig. 4), several ridges are parallel to the anterior margin of the shield. As on the dorsal shield, differences in the reflective property of the superficial layer produce concentric markings (text-fig. 38B).

(iii) *Branchial plates* are preserved in only NMC 19610 and 19651; this description is based on the latter specimen (Pl. 13, fig. 9; text-fig. 33), since the former is incomplete. The plate is 8 mm long and 1.0–1.5 mm wide; the notch, which forms the lower border of the branchial opening, lies 6.5 mm from the anterior margin. Anterior to

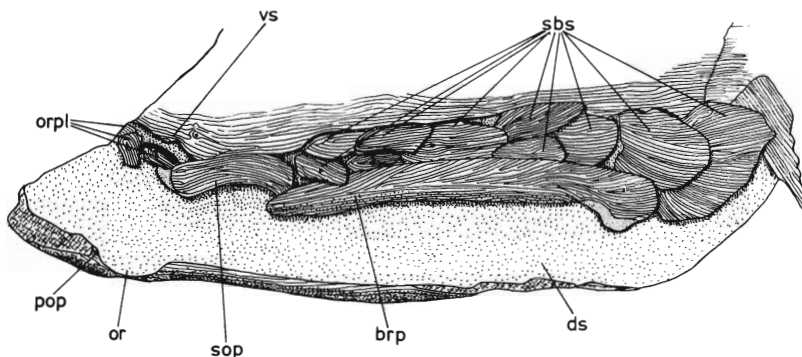

TEXT-FIG. 33. *Nahanniaspis mackenziei* gen. et sp. nov., articulated dorsal and ventral shield with branchial and sub-branchial scales in ventral aspect (NMC 19651, paratype);  $\times 6$ . *brp*, branchial plate; *ds*, dorsal shield; *or*, orbit; *orpl*, oral plates; *pop*, pre-orbital process; *sbs*, sub-branchial scales; *sop*, sub-orbital plate; *vs*, ventral shield.

the branchial notch, the dorsal margin of the plate is slightly concave; posteriorly, it expands into a dorsal lobe, the anterior and dorsal margins of which are bordered by an unornamented brim. The ventral margin of the branchial plate is convex and appears to overlap the dorsal margins of the sub-branchial scales; its anterior margin is divided into a dorsal and a ventral part, neither of which have unornamented brims. Ornamentation is of narrow dentine ridges, which are longitudinal on the dorsal half of the plate and oblique on the ventral (text-fig. 33).

(iv) *Sub-branchial scales* are preserved in only NMC 19651 (Pl. 13, fig. 9) and 19610; those of the latter specimen are too poorly preserved to contribute to the description. There are ten scales, which lie between the ventral shield and the branchial plate (Pl. 13, fig. 9; text-fig. 33). The most anterior pair are interposed between the anterior end of the branchial plate and the narrowest part of the ventral shield. They are succeeded by a similar pair of scales, the anterior margins of which they overlap. The most dorsal scale of each pair is pierced by a lateral line pore, as is the unpaired scale

#### EXPLANATION OF PLATE 14

*Nahanniaspis mackenziei* gen. et sp. nov. Articulated specimen (NMC 19673, holotype),  $\times 3$  (approx.).

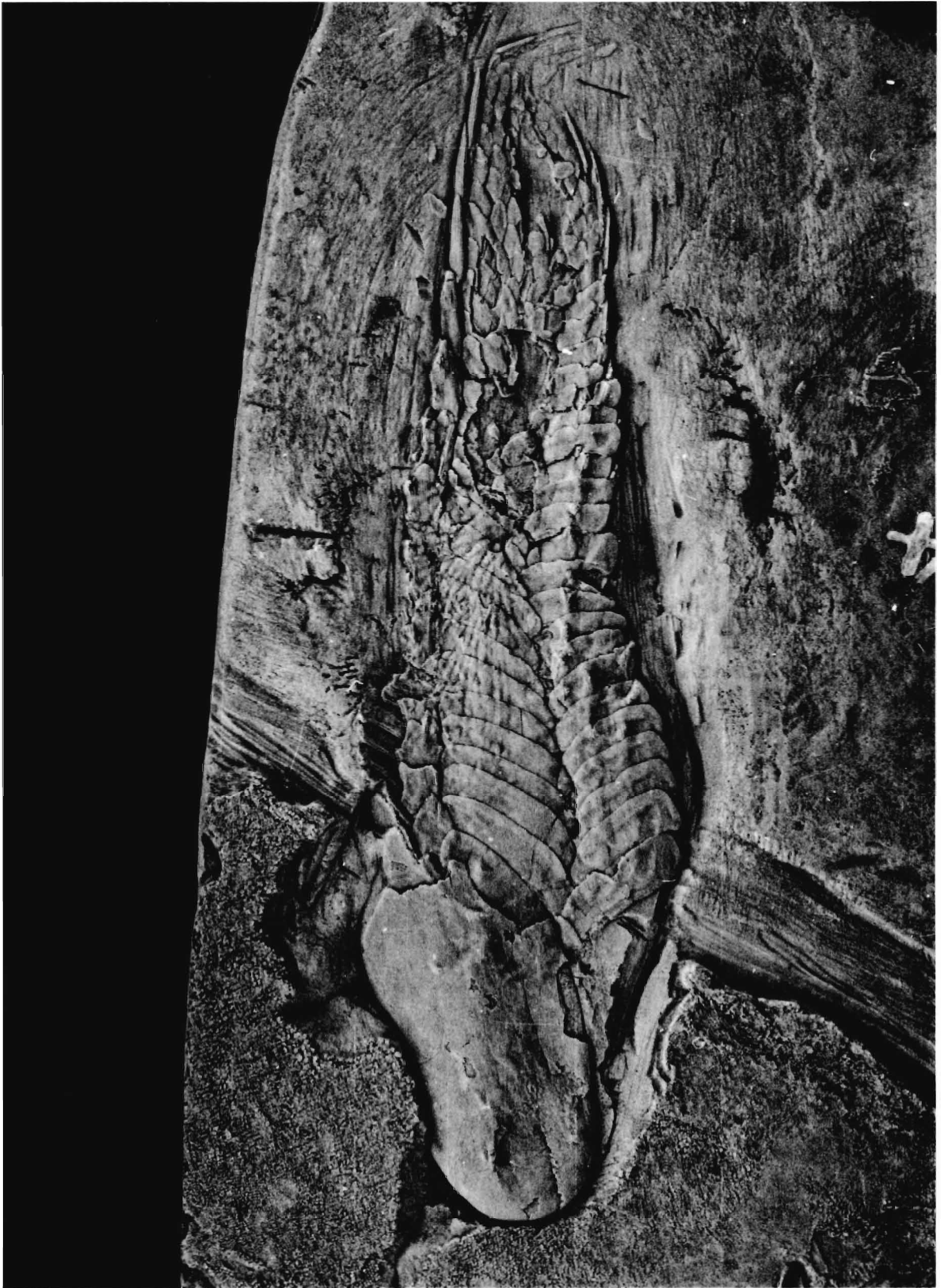

DINELEY and LOEFFLER, *Nahanniaspis mackenziei*

immediately behind them. Behind this unpaired scale, the succeeding scales are paired, but neither of this pair of scales bears a lateral line pore. The remaining three scales of the sub-branchial series are unpaired and become progressively larger posteriorly. The penultimate scale appears to articulate with the first pair of lateral body scales.

The sub-branchial scales are 1–2 mm long and 0.5–1.5 mm wide, and are slightly asymmetrical; each is ornamented with fine, longitudinal dentine ridges.

(v) *The sub-orbital plate*, which is preserved in NMC 19651 (Pl. 13, fig. 9; text-fig. 33) and 19610, is approximately 2.5 mm long. The dorsal margin is concave and the ventral margin convex, the anterior margin being divided into a short antero-ventral and a longer antero-dorsal section. The antero-dorsal margin has a narrow, unornamented border; the antero-ventral margin overlaps a small lateral plate. The posterior margin is overlapped by the branchial plate and the ventral margin by the ventral shield. Although displaced, the antero-dorsal margin of the sub-orbital plate probably articulated with the pre-orbital process.

Ornamentation is of narrow dentine ridges arranged parallel to the dorsal and ventral margins of the plate (text-fig. 33).

(vi) *?Oral plates*. In NMC 19651 (Pl. 13, fig. 9; text-fig. 33), two small plates and part of a third lie in front of the sub-orbital plate, adjacent to the antero-lateral corner of the ventral shield. The most lateral of these plates is less than 1 mm long, asymmetrical and slightly curved; its posterior margin is overlapped by the antero-ventral margin of the sub-orbital plate. This may represent a lateral plate, like that depicted in *Anglaspis heintzi* by Heintz (1962).

Adjacent to the lateral plate and close to the anterior margin of the ventral shield is a small, triangular plate with a narrow, unornamented brim. From its position, this appears to be an oral plate, although neither it, nor the lateral plate, are proportionately as large as those of *A. heintzi* (Heintz 1962). A third, more medially placed, fragment is possibly the postero-lateral margin of another oral plate (Pl. 13, fig. 9).

(vii) *Posterior body and caudal fin*. Of thirty-four specimens which include articulated scales, twenty-one are associated with identifiable fragments of dorsal or ventral shields; isolated scales can be distinguished by their narrow (eleven per mm) dentine ridges and by their small size (text-fig. 34), which distinguishes them from the scales of *Dinaspidella*, occurring at the same localities.

The posterior part of the body and the caudal fin are covered in discrete scales (Pl. 14; text-fig. 36). On the body, scales are arranged in six longitudinal series; paired dorso-lateral, paired ventro-lateral, median dorsal, and median ventral (text-fig. 34). Locally, other 'additional' scales are interposed between the median ventral

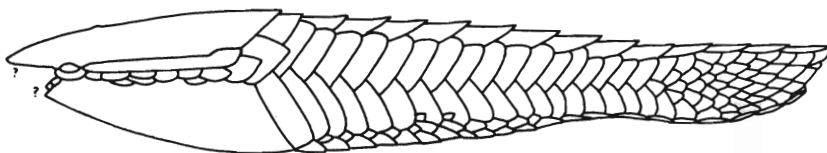

TEXT-FIG. 34. *Nahanniaspis mackenziei* gen. et sp. nov., reconstruction;  $\times 1.5$ .

and the ventro-lateral scale series (text-fig. 34). In some scale rings, there may be as many as three 'additional' scales on either side of the ventral ridge scale; in others they are absent. In some individuals, 'additional' scales are present in the second most anterior scale ring, but are absent before the fourth in others. Similarly, 'additional' scales may be present as far back as the fourteenth scale ring in some individuals, but not after the eleventh in others.

There are eighteen to twenty scale rings between the headshield and the lozenge-shaped scales of the caudal fin. Anteriorly, each comprises one ventral ridge scale, a variable number of 'additional' scales, a pair of dorso-lateral scales, and a pair of ventro-lateral scales. The dorsal ridge scales are relatively large; although part of a continuous longitudinal row, each dorsal scale corresponds to two or more scale rings. The more anterior dorsal ridge scales commonly have raised median ribs.

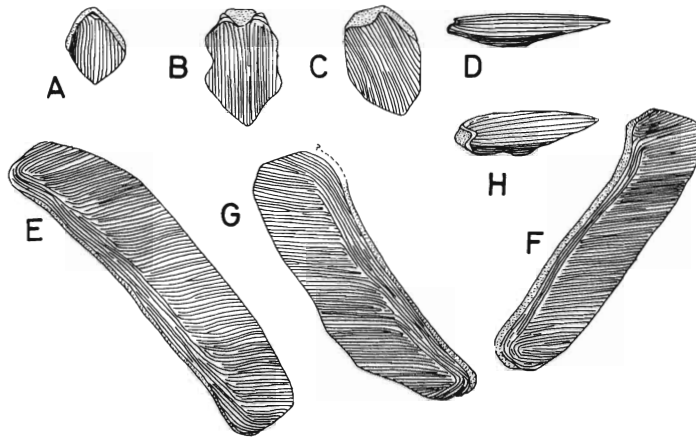

TEXT-FIG. 35. *Nahanniaspis mackenziei* gen. et sp. nov., isolated scales (NMC 19659a and b, 19662, blocks bearing numerous isolated scales);  $\times 6$ . A and C, 'additional' scales; B, D, and H, ridge scales; E, F, and G, lateral scales.

Individual scales (text-fig. 35) are very similar to those of *Poraspis* described by Kiaer and Heintz (1935); *Nahanniaspis mackenziei* differs in having finer dentine ridges and in having dorso-lateral and ventro-lateral scales of similar size. The 'additional' scales are symmetrical and, although slightly smaller, are of similar shape to the more anterior ventral ridge scales. Most of the scales become progressively smaller toward the tail, with the exception of the ridge scales; these change from being short and broad, anteriorly, to become long and slender ('fulcral' scales of Kiaer and Heintz 1935), posteriorly. The disruption and fragmentation of the ventral scales slightly anterior to the caudal fin seen in many of the articulated specimens may indicate the position of the anus.

Toward the tail, dorso-lateral and ventro-lateral scales are progressively replaced by small, lozenge-shaped scales (text-fig. 36). The caudal fin is made up of lozenge-shaped scales, and bordered on its dorsal and lateral margins by elongated fulcral scales. The caudal fin, which appears to have been laterally compressed, is almost



entire in the holotype (NMC 19673; Pl. 14), and less so in NMC 19582 and NMC 21453. In each of these, the caudal fin is slightly asymmetrical, but there is no distinct division into epichordal and hypochordal lobes. The holotype is the only specimen in which it is possible to determine that the fin is heterocercal, the more posterior extremity being dorsal (Pl. 14; text-fig. 36).

On the body and tail scales, dentine ridges are largely parallel to the length of the body, but give way to transverse and oblique ridges parallel to the anterior and antero-lateral margins of individual scales (text-fig. 36). When scales are *in situ*, unornamented brims and transverse ridges are completely overlapped by the posterior margins of the preceding scale (Pl. 13, fig. 9).

(viii) *Lateral line system*. On a reversed dorsal shield, NMC 19659b (Pl. 13, fig. 2; text-fig. 32A), the lateral line canals are represented by grooves on the ventral surface. The supra-orbital canals are continuous with the median dorsal canals, which give rise to three posteriorly placed pairs of transverse commissures. The lateral dorsal

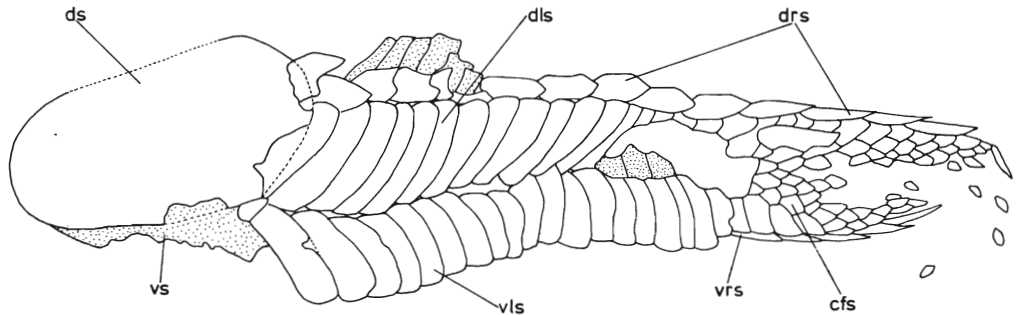

TEXT-FIG. 36. *Nahanniaspis mackenziei* gen. et sp. nov., articulated specimen (NMC 19673, holotype);  $\times 2$ . *cfs*, caudal fin scale; *dls*, dorso-lateral scale; *drs*, dorsal ridge scale; *ds*, dorsal shield; *vls*, ventro-lateral scale; *vrs*, ventral ridge scale; *vs*, ventral shield.

canals are not visible on the reversed specimen but can be detected on other dorsal shields, from the distribution of lateral line pores. On the ventral shield, pores are too scattered to permit tracing of the lateral line canal system. On one ventral shield, NMC 19533, the lateral line canals are represented by shallow grooves on the dorsal surface, presumably as a result of collapse of the cancellous layer. At least six pairs of median ventral transverse commissures are present. Single lateral line pores are present on the more dorsal of each of the first two pairs of sub-branchial scales and on the third; there are no pores on the branchial plate (text-fig. 33). Lateral line pores are present on some of the dorso-lateral and ventro-lateral body scales. Although most of these pores are situated close to the lateral mid-line, some are rather more ventrally placed.

*Remarks.* Lacking epitega and having a simple lateral line network, *N. mackenziei* could be included within the Poraspidinae, but certain characters suggest a grouping in the Irregulareaspidinae with *Dinaspidella* Strand and *Irregulareaspis*. *Nahanniaspis* gen. nov., *Dinaspidella*, and *Irregulareaspis* (see Denison 1964) all have dorsal shields of rather uniform width, broadly rounded rostra, posteriorly situated orbits and

pineal organ, ventral shields with concave lateral margins, dorso-lateral and ventro-lateral body scales of similar size, ornamentation of fine whorled ridges, and a very thin dermal skeleton. Sub-branchial scales are known in *Nahanniaspis* and *Dinaspidella* (this work); the shape of the lateral margins of the ventral shield (see Denison 1964), indicate that they were also present in *Irregulariaspis*. The lateral line system of *Nahanniaspis* (text-fig. 32A) resembles that of *Dinaspidella* (Kiaer 1932) in having supra-orbital canals continuous with the median dorsal canals; this condition, which is otherwise unknown in the Cyathaspididae, was regarded by Kiaer (1932) as primitive.

### Cyathaspididae indet., Type 1

Plate 10, fig. 10

*Material.* NMC 19770, an incomplete dorsal shield.

*Locality.* GSC 69017.

*Description.* The dorsal shield is estimated to have been approximately 30 mm long and 17 mm wide. The orbital notches are deep and the rostrum is constricted by them (Pl. 10, fig. 10), where pre-orbital processes are well developed. Although there is a slight constriction of the shield in the region of the branchial notches, postbranchial lobes do not appear to be developed. The only indication of subdivision into epitega is the presence of short ridges, where the boundary between lateral and central epitega should lie; a boundary between a rostral and central epitegum is not determinable, owing to poor preservation.

Anteriorly, short wide ridges (four per mm) radiate from the conspicuous pineal macula (Pl. 10, fig. 10); ridges are commonly curved around individual pores of the supra-orbital lateral line canal. With the exception of several coarse ridges arranged parallel to the lateral margin, the ornament of the rest of the dorsal shield is in the form of fine (eight per mm), long dentine ridges.

*Remarks.* With coarse ornament anteriorly and fine ornament posteriorly, this single incomplete dorsal shield may represent a new genus, but its affinities are dubious, since the presence of epitega cannot be determined.

### Cyathaspididae indet., Type 2

Plate 10, fig. 11

*Material.* NMC 21427, a single, crushed, incomplete dorsal shield.

*Locality.* GSC 58497.

*Description.* The dorsal shield is estimated to have been approximately 14 mm wide and over 24 mm long. The orbital notches are deep, the pre-orbital processes well developed, and a rostral process lacking (Pl. 10, fig. 11). Although lateral epitega appear to be separate from the central epitegum, there does not seem to be a separate rostral epitegum; this may be a result of crushing.

Coarse dentine ridges have a density of 4.5–5.0 per mm on the central epitegum and 3.5–4.0 per mm on the rostrum. On the lateral epitega, ridges are curved around the orbital notches but become longitudinal posteriorly. On the rostrum, ridges are

concentric about a point on the front margin, but are irregular in the inter-orbital region; posteriorly, ridges are longitudinal. The pineal area is obscured by crushing.

*Remarks.* Distortion which obscures details of the epitega precludes assigning this specimen to a smaller taxon.

#### Cyathaspididae indet.

Specimens too poorly preserved to warrant full description are listed by locality.

##### CS YA17

Horizon 8F: NMC 13809, indeterminate ventral shield (32 × 25 mm), dentine ridges at five per mm; NMC 13810, incomplete ventral shield (30 × 20 mm), dentine ridges at six to seven per mm; NMC 13811, indeterminate shield fragment, five ridges per mm; NMC 13812, dorsal shield fragment including orbital notch.

Horizon 9F: NMC 13818, large indeterminate shield fragment, four ridges per mm.

##### CS YG1

Horizon 6F: NMC 13803, internal mould of dorsal shield (60 × 32 mm), with median longitudinal axial structure resembling that of *Torpedaspis* Broad and Dineley (1973); NMC 13804, internal mould of indeterminate shield (25 × 12 mm); NMC 13805, indeterminate shield fragment, five ridges per mm; NMC 13806, internal mould of small dorsal shield (35 × 30 mm), dentine ridges at five per mm; NMC 13807, indeterminate shield fragment; NMC 13808, ventral shield fragment.

Horizon 9F: NMC 13817, reversed, poorly preserved dorsal shield (35 × 20 mm).

##### CS YE41

Horizon 3F: NMC 13813, rostral fragment with broadly rounded rostral margin and ridges of varying width.

##### CS YEx37b

NMC 13814, indeterminate fragment with six ridges per mm; NMC 13815, indeterminate fragment, five ridges per mm.

#### GENERAL COMMENTS ON THE CYATHASPIDIDAE

##### *Morphology of the armour in the Cyathaspididae*

Denison's (1964) monograph on the Cyathaspididae provided a comprehensive view of the morphology of the armour. Only the articulated specimens of *Dinaspidella* sp. indet. and *N. mackenziei* from the District of Mackenzie add to that account.

Although Kiaer's reconstruction of the body of *Anglaspis* (Kiaer 1932) is commonly reproduced in discussions of cyathaspidid anatomy (Denison 1964; Miles 1971), the two articulated specimens upon which it was based have not yet been figured or described. (According to N. Heintz (pers. comm.), the late Professor A. Heintz was working on the description of the articulated specimens of *Anglaspis*.) The Red Bay Group of Vestspitsbergen has also yielded an articulated specimen of *Irregulareaspis*

which has been figured (Kiaer 1932, pl. 5) but not described. The only other articulated cyathaspidid known is *Torpedaspis* (Broad 1971; Broad and Dineley 1973). Reconstructions of *Poraspis* (Kiaer and Heintz 1935) were clearly based on that of *Anglaspis*.

(i) *Headshield*. In Kiaer's (1932) reconstruction of *Anglaspis*, the dorsal and ventral shields were separated laterally by narrow branchial plates. From the position of the overlap margins in *Poraspis*, Kiaer and Heintz (1935) concluded that the attachment of the branchial plate was to the ventral shield and to the post-branchial part of the dorsal shield. In *N. mackenziei* and apparently also in *Dinaspidella*, a series of sub-branchial scales is interposed between the branchial plate and the indented lateral margin of the ventral shield. This arrangement, found only in the Irregulareaspidae, may have allowed for changes in volume of the headshield associated with feeding and respiration. It appears that the sub-orbital plate in *Nahanniaspis* articulated anteriorly with the pre-orbital process, posteriorly with the branchial plate and ventrally with the ventral shield; in *Poraspis* and *Anglaspis* (Kiaer 1932; Kiaer and Heintz 1935) a lateral plate was supposed to have been interposed between the ventral margin of the sub-orbital plate and the ventral shield. Oral plates are known in *Anglaspis* (Heintz 1952) and in *Allocryptaspis* (Denison 1960); the only possible equivalents of these in *Nahanniaspis* are the minute and fragmented plates described on page 98. They are most similar to the oral plates of *Anglaspis*, but are much smaller and their function is uncertain. A specimen of *Poraspis* cf. *P. polaris* described above (p. 77) has, however, a single large oral plate which may have been used like a shovel or scoop.

(ii) *Posterior body and caudal fin*. Isolated scales have been described in *Allocryptaspis* (Denison 1960) and *Poraspis* (Kiaer and Heintz 1935); although their arrangement may differ, the shapes of cyathaspidid scales conform to a general plan. Unless characterized by size or by peculiarity of ornamentation, it is impossible to attribute isolated scales to a particular genus.

In the reconstruction of *Anglaspis*, Kiaer (1932) showed six longitudinal series of scales; median dorsal, paired dorso-lateral, paired ventro-lateral, and median ventral. These were arranged in eight scale-rings, in each of which the ventro-lateral scales were much smaller than the dorso-lateral scales. As the scales are relatively large, and scale-rings few in number, the body may have been relatively inflexible.

The scales of *Irregulareaspis* (Kiaer 1932, pl. 5) are arranged in similar scale-rings, but the dorso-lateral and ventro-lateral scales are of like size; only the first few scale-rings are visible in the illustration (ibid.). In *Torpedaspis* (Broad 1971; Broad and Dineley 1973), there are eight longitudinal series of scales (the six of *Anglaspis* plus a paired series of lateral scales). The specimens described by Broad and Dineley (1973) were poorly preserved, but give the impression of a short trunk, with nine scale rings.

In *Nahanniaspis* and *Dinaspidella*, the scales are relatively smaller than in *Anglaspis* and *Torpedaspis*; in *Dinaspidella* there are ten to twelve scale-rings and in *Nahanniaspis* (text-fig. 37) there are eighteen to twenty. In both genera, as in *Irregulareaspis* (Kiaer 1932), the dorso-lateral and ventro-lateral scales are of similar size. Such an arrangement would have produced a more flexible trunk than that of *Anglaspis*. *Irregulareaspis*, *Dinaspidella*, and *Nahanniaspis* are closely related, and squamation of this type was

possibly restricted to the Irregulareaspidinae. A poorly preserved specimen of *Homalaspidella* cf. *H. borealis* has, however, dorso-lateral and ventro-lateral scales of similar size. The squamation of the Cyathaspidinae remains unknown.

The caudal fin of the Cyathaspididae has been described only in *Anglaspis* and *Torpedaspis*. In *Anglaspis* it has been shown as a reversed heterocercal caudal fin (Kiaer 1932); in *Torpedaspis*, it is diphyrcercal, with a median lobe. Denison (1971), in the light of the work of Grove and Newell (1936) and Affleck (1950), could not deduce how the fin functioned without information about the stiffness and position of the notochordal axis. The caudal fin of *Nahanniaspis* has a degree of asymmetry similar to that of *Anglaspis*, but the larger lobe is dorsally situated in a normal heterocercal arrangement. This difference between *Anglaspis* and *Nahanniaspis* may result from Kiaer's (1932) reconstruction; if the caudal fins are different, this might be associated with the relative flexibility of the trunk. *Nahanniaspis* may have been able to alter the relative position of the caudal fin and body in the vertical plane, depending on its hydrodynamic requirements (see Denison 1971, p. 90).

The irregularity of the squamation is an unexpected feature in the numerous articulated specimens. The 'additional' scales of *Dinaspidella* and *Nahanniaspis* vary in number and position in different individuals; the number of dorsal ridge scales does not correspond with the number of scale-rings, and the overlap relationship of scales of a particular type varies throughout the length of the body of a particular individual. The suggestion that each scale-ring corresponded to one metamere of the body (Kiaer and Heintz 1935) is not disproved, but the irregularity of the scales weakens the case.

#### *Growth in the Cyathaspididae*

Denison (1964) discussed previous interpretations of growth in the Cyathaspididae, and concluded that growth of the scale-units of *Tolypelepis* had not been demonstrated. He thought that there were four possible interpretations of growth of the shield: 1. The apparent tesserae, scale, and plate units of the dorsal shield all formed early in life and grew, fusing at maturity. 2. Subdivision of the dorsal shield was restricted to the superficial layer, and these superficial units may have grown, but the deeper layers did not form until maturity. 3. There was no growth of the dorsal shield, all of which formed at maturity; in this case the scale-like units would be merely relics of an earlier evolutionary stage. 4. The genus had 'cyclomorior' scales that grew and 'synchronomorior' plates that formed at once, after the animal had attained full size.

From thin sections of the shield of *Allocryptaspis* and *Cyathaspis* in which the shield was in an early stage of formation and comprised thin dentine on the ridges and thin aspidin in the grooves, Denison (1964) concluded that the superficial layer of the cyathaspidinids and poraspidinids formed prior to the deeper layers. He also suggested that the superficial layer formed over much or all of the shield at the same time. Specimens from the Delorme Formation show that the superficial layer only formed after the individual had achieved full size, but that it was a gradual rather than an instantaneous process: they also demonstrate that the epitega functioned as separate units in the growth of the superficial layer.

In *Pionaspis amplissima*, *Dinaspidella* sp. indet., *Poraspis* cf. *P. polaris*, and

*N. mackenziei*, from GSC localities 69014, 69017, and 81052, many dorsal and ventral shields have concentric markings. On a ventral shield of *Pionaspis amplissima* (NMC 19682) the bands are amplified by slight colour differences, but in all other specimens differences are marked by the reflective property of the superficial layer; alternate bands have matt or shiny surfaces.

The pattern of these bands, which are interpreted as growth features, differs with species. In *P. amplissima* the growth rings of the dorsal shield are arranged as shown in text-fig. 37A. Thus from their pattern it seems that the superficial layer grew independently within the rostral, lateral, and central epitega, and that the latter

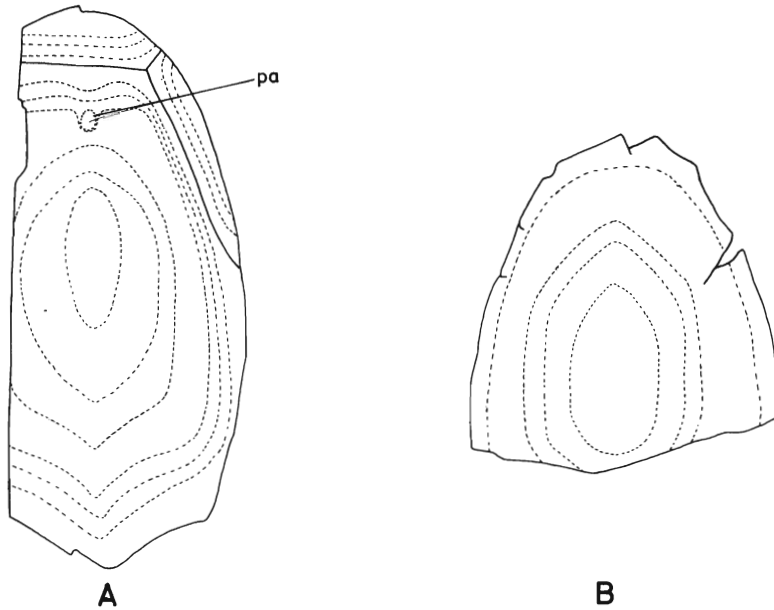

TEXT-FIG. 37. *Pionaspis amplissima* sp. nov., growth lines;  $\times 0.75$ . A, dorsal shield (NMC 19640, holotype); B, ventral shield (NMC 19682). *pa*, pineal macula.

were not in contact until they reached their final size. The initial growth stages of the central epitegum are oval and not indented anteriorly (text-fig. 37A). Later stages have a deep indentation around the pineal macula, but the final stage has a straight anterior margin. Thus the superficial layer formed independently within each epitegum; the formation of this layer did not begin until the individual had achieved full size, as indicated by the fact that the early growth stages do not have an anterior indentation for the pineal body. Indentation of the anterior margin of some of the later growth stages of the central epitegum suggests that the pineal area remained naked longer than the surrounding surface.

In *Nahanniaspis* (text-fig. 38A) and *Dinaspidella* (text-fig. 39A), there appear to have been two centres of growth on the dorsal disc: one on the rostrum and one toward the posterior end of the shield. Again, only the later stages are indented around the macula, suggesting that formation of the superficial layer began only after maximum

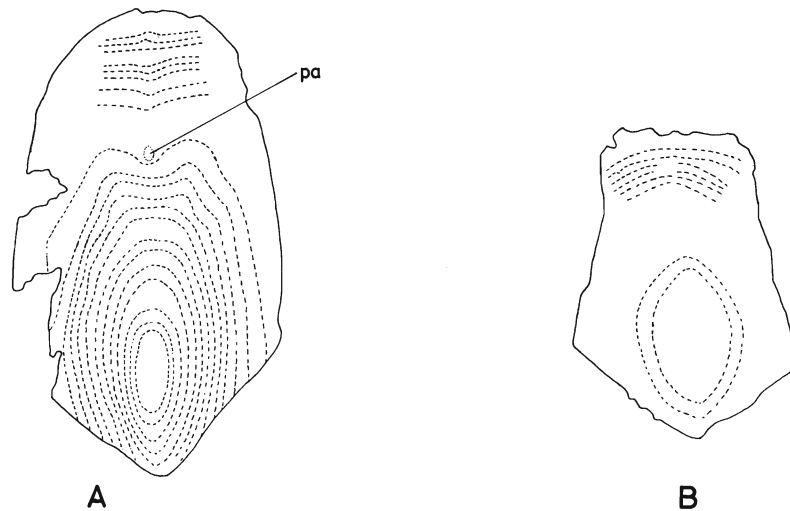

TEXT-FIG. 38. *Nahanniaspis mackenziei* gen. et sp. nov., growth lines;  $\times 3$ . A, dorsal shield (NMC 19535); B, ventral shield (NMC 19763). *pa*, pineal macula.

size had been achieved, and that the pineal region remained naked longer than adjacent areas. The ventral shields of each of these genera have a simple pattern of growth centred on a single point. In *Nahanniaspis* (text-fig. 38B) and *Dinaspidella* (text-fig. 39C) this centre is rather more posteriorly placed than in *Pionaspis* (text-fig. 37B) and the anterior growth bands are almost transverse. The growth rings of *Poraspis* cf. *P. polaris* are known from a single poorly preserved specimen. There appear to be two centres of growth, the rostral centre being as in *Dinaspidella* and *Nahanniaspis*, but the posterior centre being further forward than in the other two genera.

Although such growth bands have not previously been reported in the Cyathaspididae, more distinct superficial discordances are well known. Denison (1964, p. 462) described a ventral shield of *Americaspis americana* with an asymmetrical oval area demarcated by a groove and a discontinuity of ridges. Similar 'anomalous areas' have since been described in *Vernonaspis epitegosa* (Broad and Lenz 1972) and *Archegonaspis bimarioris* (Novitskaya 1970). Believing that the cyathaspidid shield did not grow, Denison (1964) regarded such areas as the result of an anomaly in the development of the soft tissues prior to calcification. Since it can now be demonstrated that the superficial layer of the shield underwent incremental growth, these areas can be interpreted as growth stages. Thus growth rings of the type described in the material from the District of Mackenzie are the products of normal ontogeny, the banding probably being caused by changes in metabolism; anomalous areas, such as those described in *Americaspis*, *Vernonaspis*, and *Archegonaspis* were produced by interruption of normal growth. The cause may have been disease, drastic temperature changes, or reduction or change of food supply, etc.

Although the superficial layer of the dermal skeleton of a number of heterostracans is known to have been capable of a limited amount of healing (see Denison 1973 and

references therein), products of this process had not previously been reported in the Cyathaspididae.

On the anterior margin of the holotype dorsal shield of *Pionaspis amplissima* (Pl. 9, fig. 1), secondary dentine ridges overgrow the abraded surface of the primary ridges on the rostrum and around the orbital notches. They are discordant with, and slightly broader than, adjacent ridges and appear simply to be plastered on to them. The marginal site of the overgrown area, as well as the state of the underlying ridges, suggest that abrasion led to their formation.

#### *Phylogeny of the Cyathaspididae*

It is suggested above (p. 51) that the Corvaspididae were derived from the primitive Cyathaspididae, which in turn are closely related to the early Traquairaspididae. These three groups have several features in common; the microstructure of the shield is very similar and, although apparently continuous in the deeper layers, the superficial layer is subdivided into small units. In the Tolypelepinae and primitive Cyathaspidinae, the units are scale-like; in the Corvaspididae they show a complete gradation from scale-like to cyclomoriform, and in the Traquairaspididae they are cyclomoriform. Although the function of these units is unknown, they may be relics of an early evolutionary stage; the ancestor of all these forms may have had a continuous cover of small scales, which became fused anteriorly. Since few heterostracans are known prior to the Late Silurian, it is difficult to determine such relationships.

The earliest known Heterostraci, the Ordovician *Astraspis* and *Eriptychius*, apparently had carapaces formed of polygonal plates (Denison 1967). Heterostraci are otherwise unknown until the late Early or early Middle Silurian; Thorsteinsson (1967) has reported a *Tolypelepis*-like cyathaspidid from the Late Llandoveryan or Early Wenlockian and diverse cyathaspidids from the Late Wenlockian of Cornwallis Island. Broad (1971) and Turner and Dixon (1971; see also Dixon *et al.* 1972) indicate that the Traquairaspididae and Corvaspididae were established by the Late

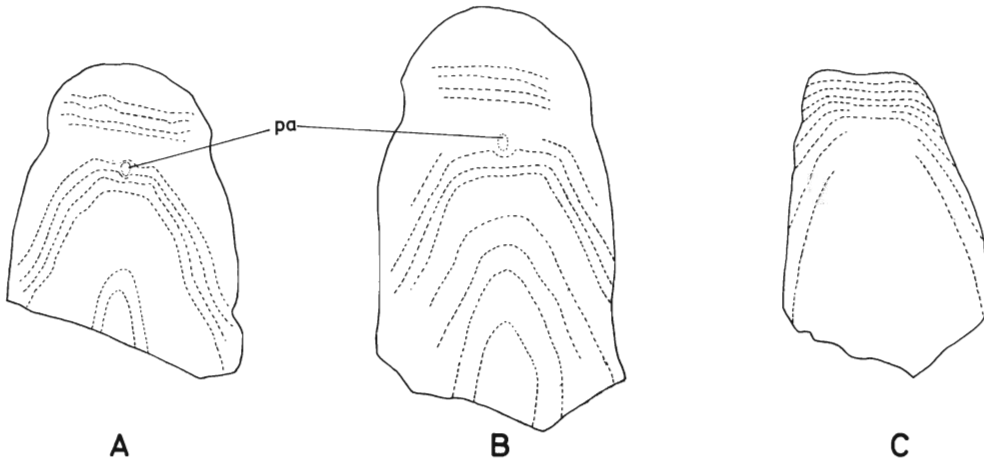

TEXT-FIG. 39. *Dinaspidella indet.*, growth lines;  $\times 1.5$ . A, dorsal shield (NMC 19500); B, dorsal shield (NMC 19541); C, ventral shield (NMC 19557). *pa*, pineal macula.



Wenlockian or Early Ludlovian. These Silurian fossils, which are obviously of great phylogenetic significance, have been neither figured nor described.

Denison (1964) regarded the five subfamilies of his Cyathaspididae as major phyletic divisions. The Tolypelepidinae were considered to include the ancestral stock, from which the Cyathaspidinae were derived by loss of scale components. Of the Cyathaspidinae, Denison saw *Ptomaspis* as the most primitive, *Archegonaspis*, *Vernonaspis*, and *Seretaspis* as unspecialized, *Cyathaspis* as occupying an isolated position, and *Listraspis* and *Pionaspis* as advanced. The Irregulareaspidinae were supposed to have been derived from the early Cyathaspidinae, *Dikenaspis* being the most primitive genus. The Poraspidinae were thought perhaps to represent an artificial assemblage of genera, which had independently lost epitega. Although *Americaspis*, *Poraspis*, *Allocryptaspis*, and European species of *Homalaspidella* were probably derived from the same stock, Denison thought that Canadian species of *Homalaspidella* might be a separate but parallel lineage. He regarded *Ariaspis* and *Anglaspis* as isolated within the subfamily. Concluding that the ancestry of the Ctenaspidinae remained obscure, Denison (1964) suggested that they may have been derived from the Poraspidinae or Cyathaspidinae by loss of the superficial layer.

Novitskaya (1973) regarded the Poraspidinae as a natural group, descended from the Cyathaspidinae. She saw *Ariaspis* and *Americaspis* as primitive poraspidinids, the latter having given rise to *Poraspis*; the *Liliaspis*-*Anglaspis*-*Allocryptaspis* and the *Homalaspidella* lineages were considered to have evolved independently from *Poraspis*.

Except in the case of the Irregulareaspidinae (see below), material from the District of Mackenzie provides no new information either to support or refute Denison's hypothesis. His subfamily Irregulareaspidinae (1964) includes *Irregulareaspis*, *Dinaspidella*, and *Dikenaspis*. *Nahanniaspis*, which has a number of features in common with *Dinaspidella* and *Irregulareaspis*, indicates that *Dikenaspis* was wrongly grouped in that subfamily. *Dinaspidella*, *Irregulareaspis*, and *Nahanniaspis* have uniformly broad dorsal shields with broadly rounded rostral margins, posteriorly placed orbits and pineal organ, and ornamentation of very fine, whorled dentine ridges. The ventral shields of these three genera are also very similar, having deeply indented lateral margins. Similarity also extends to the squamation; all three genera have dorso-lateral and ventro-lateral scales of similar size and at least two (*Dinaspidella* and *Nahanniaspis*) possess a series of sub-branchial scales. Although *Dikenaspis* has an anastomosing lateral line system superficially resembling that of *Irregulareaspis*, the only features common to the four genera are the fine ornamentation and the posteriorly situated orbits. *Dikenaspis* has a dorsal shield which is narrow anteriorly and has a distinct rostral process; the epitega reveal its cyathaspidinid affinities.

Denison's (1964) main reason for including *Dikenaspis* with the Irregulareaspidinae was obviously its anastomosing lateral line system. Comparison of the lateral line systems of *Dikenaspis*, *Nahanniaspis*, *Dinaspidella*, and *Irregulareaspis* (text-figs. 32, 40) suggests that the anastomosing pattern of *Irregulareaspis* is merely an elaboration of the simple pattern of *Dinaspidella* and *Nahanniaspis*; the main elements of the simple pattern are distinguishable in spite of excessive branching. The anastomosing pattern of *Dikenaspis* bears little or no resemblance to that of *Nahanniaspis* and *Dinaspidella*. The main features of the basic pattern are two pairs of supra-orbital

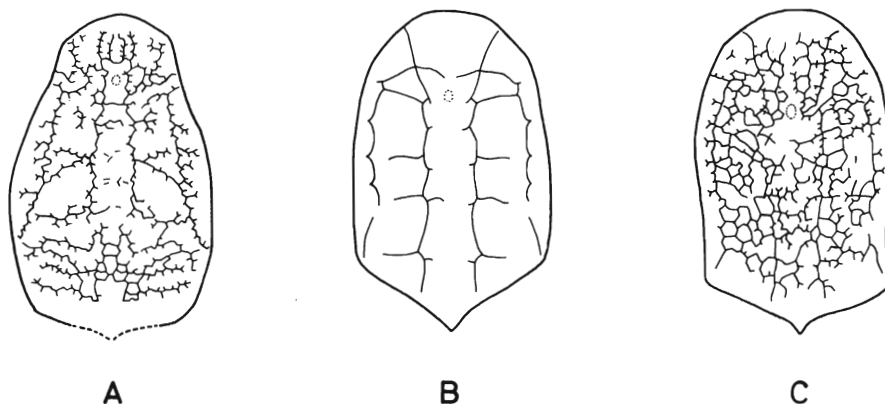

TEXT-FIG. 40. Lateral line canal systems in the Cyathaspididae (after Denison 1964).  
A, *Dikenaspis*; B, *Dinaspidella*; C, *Irregulareaspis*.

canals, a pair of curved posterior transverse commissures, and median dorsal canals which are discontinuous posteriorly (text-fig. 40A). It seems, therefore, that *Dikenaspis* is not an irregulareaspidinid, but is a cyathaspidinid in which an anastomosing lateral line system has been independently evolved. Of the features which *Dikenaspis* shares with the Irregulareaspidinae, fine dentine ridges (thirteen to fourteen per mm) are also developed in the cyathaspidinid *Listraspis* (Denison 1964). The large value for the orbital ratio in *Dikenaspis* appears to be a result of the forward protrusion of the median rostral process of the only specimen. Although the advantages of an anastomosing lateral line system are unknown, the character appears to have been independently acquired in the Cyathaspidinae, the Irregulareaspidinae, and the Traquairaspidinae.

If *Dikenaspis* is a cyathaspidinid, there is no evidence for the derivation of the Irregulareaspidinae from the Cyathaspidinae. Indeed, the lack of epitega and the pattern of the lateral line system in the primitive members of the subfamily suggest derivation from Poraspidinae close to *Poraspis*.

#### *Distribution of the Cyathaspididae*

Denison's (1964) account of the geological range of the Cyathaspididae was written when the Ludlovian was regarded as the top Stage of the Silurian System and when *Traquairaspis* was thought to be a reliable indicator of the Downtonian. The recognition of a Pridolian Stage, and the discovery that the Traquairaspididae extend at least as far back as the Ludlovian, necessitate revised correlations which give a new picture of the temporal distribution of the Cyathaspididae. Only those cyathaspidid occurrences which can be adequately dated have been included in the correlation table (Table 1). Canadian cyathaspidids which cannot be so precisely dated are shown in an accompanying chart (text-fig. 41), indicating the possible range in age of each fauna. An account of dating of each of the latter faunas is provided (p. 195).

In spite of past misidentifications, a profusion of unsubstantiated reports, and imprecise age determinations, a pattern of distribution and migrations begins to

emerge. Cyathaspidids were present in Canada in the Middle Silurian, but did not become abundant until the Late Silurian. By that time a great variety of cyathaspidids, including representatives of the subfamilies Tolypelepidinae, Cyathaspidinae, and Poraspidinae were present. European strata of the same age are poor in cyathaspidids. *Archegonaspis* is present in the Early and Middle Ludlovian, *Cyathaspis* in the Late Ludlovian and Early Downtonian and *Tolypelepis* in the ?Early Downtonian. Only within and above the *Traquairaspis* zones of the Downtonian (*sensu* White 1950a) are cyathaspidids common in Europe. Material from GSC locality 69014 (p. 6) seems to show that by the Dittonian there was little difference between the European

TABLE 1. Ages of Canadian cyathaspidid faunas. (Details of the ages of faunas described in this work are given on pp. 195–198.)

CANADIAN ARCTIC ISLANDS				
Area	Formation	Cyathaspididae	Possible age range of fauna	Source
Cornwallis Island	Cape Phillips Fm.	? <i>Tolypelepis</i> ? <i>Ptomaspis</i> ? <i>Vernonaspis</i> ? <i>Archegonaspis</i> ? <i>Homalaspidella</i>	Late Llandoveryan or Early Wenlockian to Early Ludlovian	Thorsteinsson (1967)
„ „	Snowblind Bay Fm.	<i>Anglaspis</i> Ctenaspidinae indet.	?Early Devonian	Thorsteinsson (1967)
Somerset Island and Prince of Wales Island	Transitional beds between Allen Bay and Read Bay Fms.	<i>Anglaspis</i> <i>Vernonaspis</i> <i>Pionaspis</i> <i>Ariaspis</i> <i>Homalaspidella</i>	Wenlockian or Ludlovian	Turner and Dixon (1971); Dixon <i>et al.</i> (1972)
„ „	Peel Sound Fm. (Lower member)	<i>Anglaspis</i> <i>Pionaspis</i> <i>Torpedaspis</i> <i>Listraspis</i> <i>Poraspis</i> ? <i>Ariaspis</i>	Pridolian and ?Gedinnian	Broad (1971); Broad and Dineley (1973)
„ „	Peel Sound Fm. (Upper member)	<i>Poraspis</i> <i>Ctenaspis</i>	Siegenian to Emsian	Broad, Dineley and Miall (1968); Broad (1971)
Ellesmere Island	Devon Island Fm.	<i>Boothiaspis</i>	Pridolian	Broad (1973)
WESTERN CANADA				
Beaver River (SE. Yukon)	Unnamed	<i>Vernonaspis</i> <i>Ptomaspis</i> <i>Dikenaspis</i> <i>Ariaspis</i> <i>Homalaspidella</i>	Late Silurian	Denison (1963); see also p. 196
Snake River (W. Yukon)	Gossage Fm.	<i>a. Vernonaspis</i> <i>b. ?Dinaspidella</i>	<i>a.</i> Late Silurian <i>b.</i> Early Devonian	<i>a.</i> Broad and Lenz (1972) <i>b.</i> Denison (1964); see also p. 197
Muncho Lake	Muncho-McConnell Fm.	<i>Listraspis</i> <i>Pionaspis</i>	?Early Devonian	Denison (1964); see also p. 197
Mount Sekwi	?Delorme Fm.	<i>a. Vernonaspis</i> <i>b. Anglaspis</i>	<i>a.</i> Late Silurian <i>b.</i> Early Devonian	Denison (1964); see also p. 197

	ANGLO WELSH CUVETTE	VEST- SPITSBERGEN	PODOLIA	SAAREMAA	N. GERMANY (erratics)	URALS	LITHUANIA & LATVIA
EMSIAN	U						
	M						
SIEGENIAN	L						
	M						
GEDINNIAN	U						
	L						
	U						
	L						
PRIDOLIAN	U						
	L						
LUDLOVIAN	U						
	L						

Region	Subregion	Faunal Assemblage
ANGLO WELSH CUVETTE	BRECONIAN	WOOD BAY FORMATION
	DITTONIAN	FRANCE Anglaspis Poraspis
	DITTONIAN	OSAMMITES DE LIEVIN Anglaspis Poraspis
	DOWNTONIAN	FRAENKELRYGGEN Poraspis Anglaspis cf. Clenaspis
VEST-SPITSBERGEN	BEN NEVIS FM.	Homolaspidella Poraspis Anglaspis Irregularaspis Clenaspis
	GERMANY & POLAND (erratics)	Anglaspis Clenaspis Dinaspidella Poraspis cf. Clenaspis
	GESTEIN	
	GRAPTOLITHEN	Archegonaspis
PODOLIA	OLD RED GR.	Poraspis
	BORSHCHOVICHKOV H.	Irregularaspis Poraspis Clenaspis Seretaspis
SAAREMAA	SKALA	Irregularaspis
	K1, K2, K3a, K3b, K4	Tolypelepis
N. GERMANY (erratics)	BEYRICHENKALK ERRATICS	Anglaspis Tolypelepis
URALS		Lilaspis
	GOTLAND	
LITHUANIA & LATVIA	SESUVI FM.	
	PAGEGAI, MINIJA, JURA, TIL'ZE, STONISKYAI SUITE	Tolypelepis

	TIMAN	SIBERIA	WYOMING	UTAH	OHIO	NEW BRUNSWICK
EMSIAN	U					
	M					
SIEGENIAN	L					
	M					
GEDINNIAN	U					
	L					
	U					
	L					
PRIDOLIAN	U					
	L					
LUDLOVIAN	U					
	L					

Region	Subregion	Faunal Assemblage
TIMAN	BRECONIAN	
	DITTONIAN	
SIBERIA	ZUBOVA	Steinaspis
	EPTARMA	VAYGACH IS. (USSR)
WYOMING	BEAR TOOTH BUTTE FM.	Alloocyrtaspis
	NEW YORK NEW JERSEY PENNSYLVANIA	
UTAH	WATER CANYON FORMATION	Alloocyrtaspis
	NEW YORK NEW JERSEY PENNSYLVANIA MARYLAND	
OHIO	HOLLAND QUARRY SHALE	Alloocyrtaspis
	PENNSYLVANIA MARYLAND	
NEW BRUNSWICK	JONES CREEK FM.	Cyathaspis

TEXT-FIG. 41. Distribution of Late Silurian and Early Devonian Cyathaspididae (see Table 1 for details of western Canadian faunas).

and Canadian ostracoderm faunas. Cyathaspidids are unknown after the Late Downtonian, the last occurring in the western U.S.A. Although some Late Silurian cyathaspidids are unquestionably marine, Late Downtonian and Dittonian forms occur almost exclusively in brackish and fluvial sediments.

The Cyathaspididae may first have appeared within the tropical shelf seas of the North American continent prior to the Late Silurian. Throughout the Late Silurian they diversified in the shallow, marginal, and open marine environments there. The ocean strait ('Iapetus' of Harland and Gayer 1972), which separated the European and North American continents, hindered migration during the Late Silurian. *Archegonaspis*, *Cyathaspis*, and *Tolypelepis* were amongst the few heterostracans which succeeded in crossing it to reach Europe. The major influx of heterostracans to Europe, toward the end of the Downtonian, marks the disappearance of the ocean barrier. At this time, coincident with the first appearance of Traquairaspididae and Corvaspididae in Europe, the cyathaspidids arrived in strength. By then, the Cyathaspidinae and Tolypelepidinae had virtually disappeared, the Cyathaspididae being represented by the Poraspidinae, Ctenaspidinae, and Irregulareaspidinae. During the Late Downtonian and Dittonian (*sensu* White 1950a), the cyathaspidids continued to diversify; it is probable that the Ctenaspidinae and Irregulareaspidinae arose during this time. These Late Downtonian and Dittonian cyathaspidids occupied the new environments which became available with the growth of a continental area resulting from the Caledonian orogeny.

The success of the cyathaspidids was relatively short-lived; although they survived locally (Vestspitsbergen and western U.S.A.) until the Late Dittonian, cyathaspidids have not been reported from post-Dittonian strata.

#### FAMILY PTERASPIDIDAE WHITE, 1935

*Diagnosis* (after White 1935). Heterostraci with dorsal shield superficially divided into nine plates: unpaired rostral, pineal, and dorsal plates, paired orbital, branchial, and cornual plates. Median dorsal spine inserted into posterior margin of dorsal disc; oral plates small and numerous. Ornamentation fine and commonly serrated. Body scales small, numerous, and rhomboidal.

*Remarks*. Denison (1970) divided the family Pteraspididae into two subfamilies, the Doryaspidinae, containing *Doryaspis*, and the Pteraspidinae, containing all other pteraspids. Pteraspidid classification is discussed in detail elsewhere (p. 127).

#### Subfamily PTERASPIDINAE Denison, 1970

*Diagnosis* (after Denison 1970). Pteraspidids with rostral plate extending anteriorly over mouth; no pseudo-rostrum on ventral shield.

*Genera*. *Protopteraspis* Leriche, *Zascinaspis* Stensiö, *Pteraspis* Kner, *Althaspis* Zych, *Rhinopteraspis* Jaekel, *Belgicaspis* Zych, *Protaspis* Bryant, *Oreaspis* Denison, *Lampraspis* Denison, *Psephaspis* Ørvig, *Canadapteraspis* gen. nov., *Loricopteraspis* Tarlo, *Brotzenaspis* Stensiö.

#### Genus CANADAPTERASPIS gen. nov.

*Diagnosis*. Moderate-sized pteraspidids with slightly elongate rostra; ventral surface of rostrum with pre-oral field bearing ornament of irregularly arranged ridges.

Branchial openings placed well in advance of postero-lateral corners of shield, bounded anteriorly by branchial plates and posteriorly by well-developed cornual plates. Posterior extension of orbital plates moderately to extremely long. Where preserved, lateral line system with supra-orbital canals extending on to dorsal disc.

*Remarks.* The affinities of *Canadapterspis* are discussed elsewhere (see p. 129).

*Type species.* *C. alocostomata*.

*Other species.* *C. thymostomata* sp. nov., *C. helostomata* sp. nov., *C. whitei* (Denison).

### *Canadapterspis alocostomata*

Plate 15, figs. 1–3; Plate 17, figs. 2, 3; text-figs. 44–47

*Diagnosis.* Dorsal shield (excluding spine but including rostrum) estimated to be approximately 70 mm long; pineal plate small and circular, in contact with medial extensions of orbital plate; posterior extensions of orbital plates moderately long.

*Holotype.* NMC 19993, incomplete dorsal shield (Pl. 17, fig. 3).

*Paratypes.* NMC 19992, incomplete dorsal shield (Pl. 15, fig. 3); NMC 21457, sub-rostral surface (Pl. 17, fig. 2; text-fig. 44); NMC 21458, ventral disc (Pl. 15, fig. 2).

*Other material.* NMC 19959–19974, 19991, 19994–19999, 21340–21348.

*Locality.* GSC 69014.

*Description.* In the holotype (NMC 19993) the dorsal disc is 51 mm long and 34 mm wide, but in the only other essentially complete specimen (NMC 19992) it is 42 mm long and 36 mm wide; variation in proportions may be a result of crushing. Total length of the dorsal shield, including the rostral plate but excluding the dorsal spine, is estimated to have been about 70 mm in the holotype.

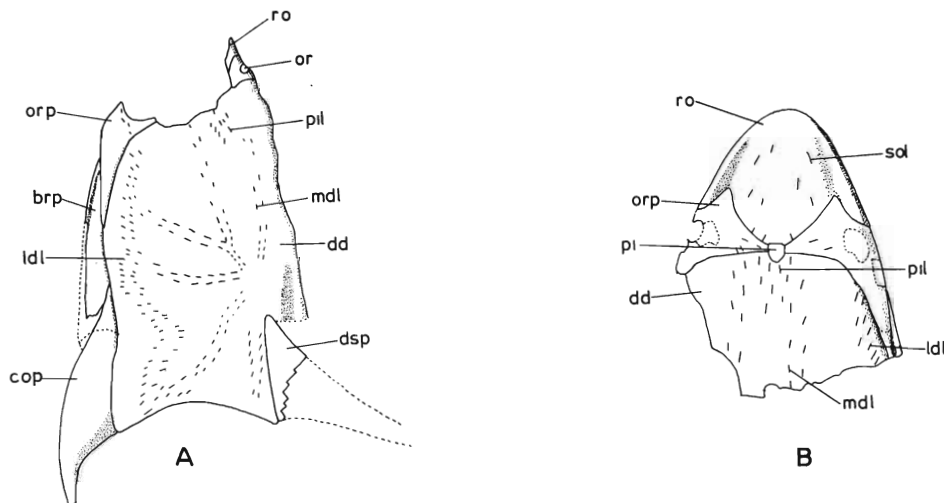

TEXT-FIG. 42. *Canadapterspis alocostomata* gen. et sp. nov., morphology of dorsal shield;  $\times 1$ . A, incomplete dorsal shield (NMC 19992, paratype); B, incomplete dorsal shield (NMC 21340). *cop*, cornual plate; *brp*, branchial plate; *dd*, dorsal disc; *dsp*, dorsal spine; *ldl*, pores of latero-dorsal canal; *mdl*, pores of medial dorsal canal; *or*, orbit; *orp*, orbital plate; *pi*, pineal plate; *pil*, pores of inter-orbital canal; *ro*, rostrum; *sol*, pores of supra-orbital canal.

The dorsal disc, which is rather flat, has a small anterior notch for the reception of the pineal plate and a deep, narrow, posterior notch for the dorsal spine (Pl. 15, fig. 3). The antero-lateral corners of the dorsal disc are gently rounded (text-fig. 43A); the postero-lateral margins, which meet at the posterior median angle, are slightly concave (text-fig. 42A).

The branchial openings, which are situated approximately 20 mm in advance of the postero-lateral corners of the dorsal shield, are bounded anteriorly by branchial plates and posteriorly by falciform cornual plates (Pl. 15, fig. 3). The cornual plates have a base of attachment which is approximately 20 mm long; their width is about

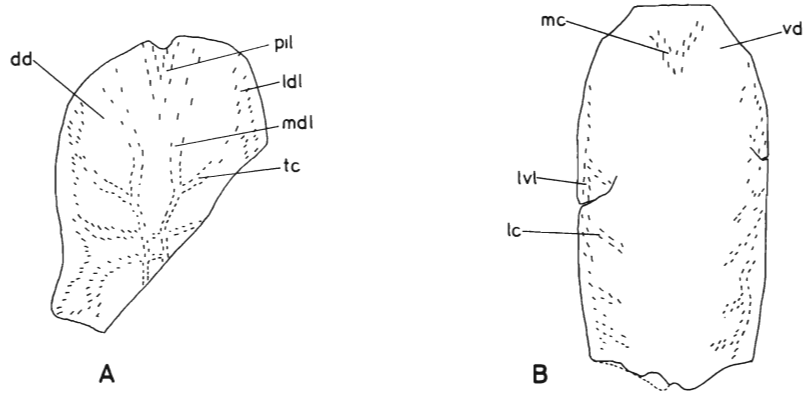

TEXT-FIG. 43. *Canadapterspis alocostomata* gen. et sp. nov., distribution of lateral line pores;  $\times 1$ . A, incomplete dorsal disc (NMC 19997); B, ventral disc (NMC 21458, paratype). *dd*, dorsal disc; *lc*, pores of lateral canal; *ldl*, pores of lateral dorsal canal; *lvl*, lateral ventral line; *mdl*, pores of medial dorsal canal; *pil*, pores of pineal canal; *mc*, pores of post-oral canal; *tc*, pores of transverse commissure; *vd*, ventral disc.

8 mm. The tip of the cornual plate extends a further 10 mm beyond the postero-lateral corner of the shield (text-fig. 42A).

The moderately elongated rostral plate is gently rounded anteriorly (text-fig. 44). The median extensions of the orbital plates are in contact with the small pineal plate, but their posterior extensions are not exceptionally long. A well-developed branchial plate forms the lateral margin of the dorsal shield for much of its length, extending ventrally as a wide ventro-lateral brim. The dorsal spine is erect and prominent (Pl. 15, fig. 3). In NMC 19992 (Pl. 15, fig. 3) the vertical height of the dorsal spine is 19 mm and the length of the inserted portion is 12 mm; the anterior margin is slightly concave and the posterior margin straight. The dorsal shield has an ornament of laterally serrated dentine ridges with a density of nine per mm.

#### EXPLANATION OF PLATE 15

Figs. 1-3. *Canadapterspis alocostomata* gen. et sp. nov. 1, incomplete dorsal shield (NMC 21340),  $\times 2$  (see text-fig. 42B). 2, ventral disc (NMC 21458, paratype),  $\times 2$  (see text-fig. 43B). 3, incomplete dorsal shield (NMC 19992, paratype),  $\times 2$  (see text-fig. 42A).

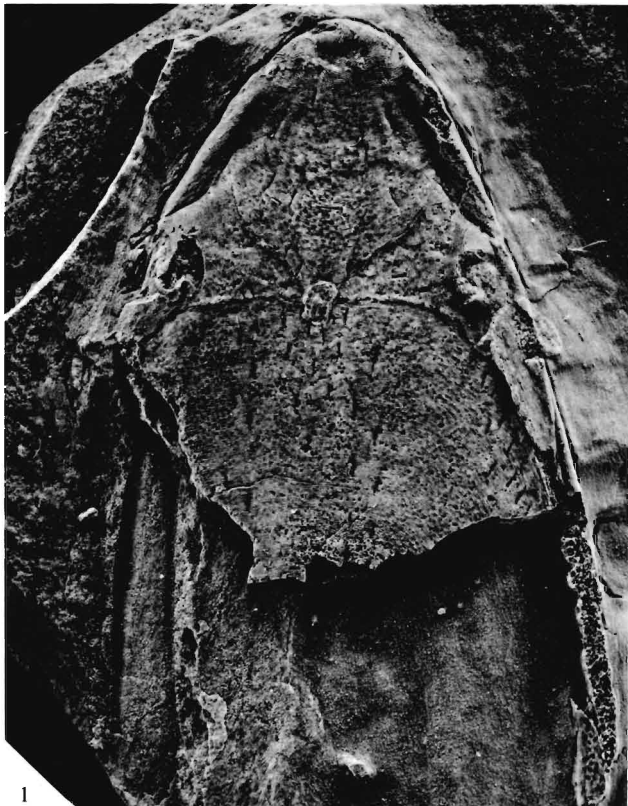

DINELEY and LOEFFLER, *Canadapteraspis*



On the underside of the rostrum, a distinct pre-oral field is elevated above the sub-rostral surface and ornamented with dentine ridges (Pl. 17, fig. 2; text-fig. 44). The ridges are not as well defined or as regular as those of the rest of the dorsal shield; they fan forward from an elevated area which marks the posterior margin of the pre-oral field. An ascending lamella slopes up and back from the posterior margin of the pre-oral field (text-fig. 44).

Among the four ventral discs measured (NMC 19959, 19964, 19967, 21458), the length varies from 46 to 61 mm and the width from 24 to 30 mm. The anterior margin is transverse, the antero-lateral margins obliquely truncated, and the lateral margins

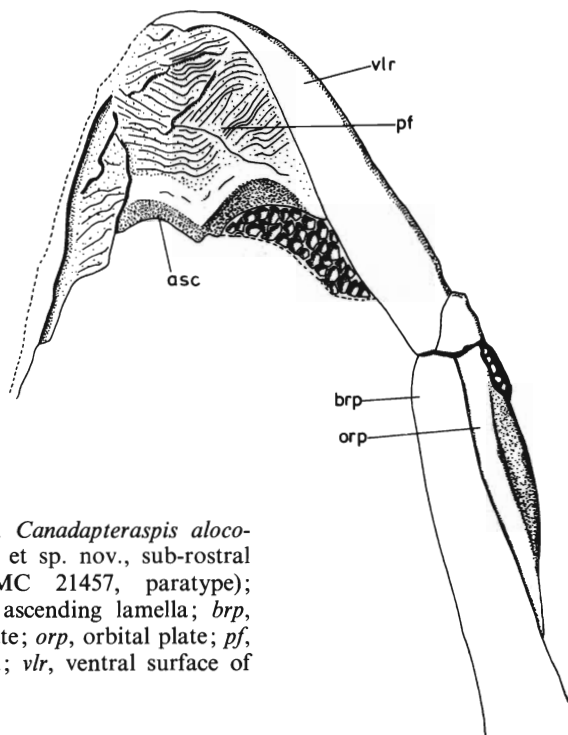

TEXT-FIG. 44. *Canadapterspis aloco-stomata* gen. et sp. nov., sub-rostral surface (NMC 21457, paratype);  $\times 3.75$ . *asc*, ascending lamella; *brp*, branchial plate; *orp*, orbital plate; *pf*, pre-oral field; *vlr*, ventral surface of rostrum.

slightly convex (Pl. 15, fig. 2); the posterior margin, although generally convex, has a shallow median notch. Dentine ridges are slightly coarser than on the dorsal shield, having an average density of eight per mm.

Lateral line pores are distinct on both dorsal and ventral discs (Pl. 17, fig. 3; Pl. 15, fig. 2). On the dorsal disc, the system forms a closed network, almost equal in extent to the area of disc (text-fig. 43A); the full complement of canals is present on the dorsal shield, but on the ventral shield only five pairs of postero-medially directed branches arise from the lateral ventral canals (text-fig. 43B). The inter-orbital canal forms a deep V on the anterior end of the dorsal disc; the medial dorsal canals extend to the anterior end of the dorsal disc and appear to join the transverse portions of the inter-orbital canals within the medial extensions of the orbital plates.

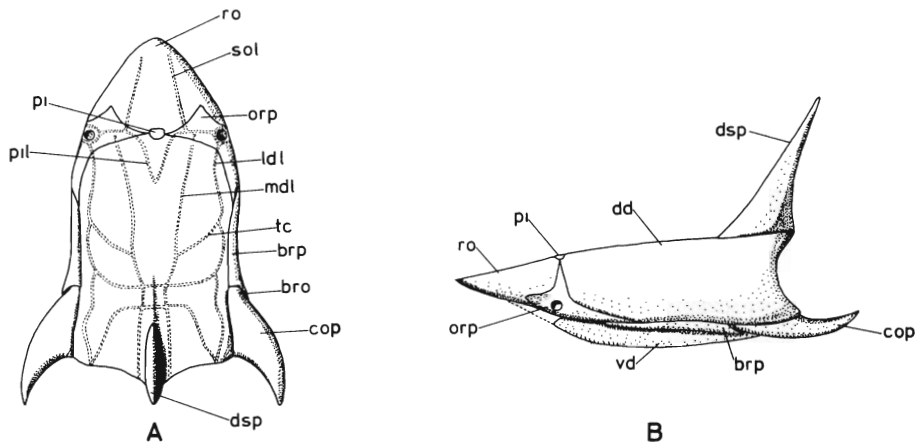

TEXT-FIG. 45. *Canadapteraspis alocostomata* gen. et sp. nov., reconstruction of headshield;  $\times 0.75$ . A, dorsal view, with lateral line canals shown; B, lateral view. *bro*, branchial opening; *brp*, branchial plate; *cop*, cornual plate; *dd*, dorsal disc; *dsp*, dorsal spine; *ldl*, lateral dorsal canal; *mdl*, medial dorsal canal; *orp*, orbital plate; *pi*, pineal plate; *pil*, pineal canal; *ro*, rostrum; *sol*, supra-orbital canal; *tc*, transverse commissure; *vd*, ventral disc.

*Remarks.* The presence of a distinct pre-oral field ornamented with dentine ridges excludes this species from established genera and characterizes the new genus *Canadapteraspis*. The relatively large areal extent of the lateral line network indicates that this is a primitive species. White (1958) demonstrated that growth of the shield in early pteraspids ceased soon after the incorporation of the lateral line network into the dorsal disc, but that in later pteraspids there was an increasing amount of growth afterwards.

Extension of the inter-orbital canal on to the dorsal shield is also regarded as primitive (Denison 1970); in addition to being present in *Canadapteraspis*, it is a feature known in *Protopteraspis* (including *Simopteraspis*) and in ?*Pteraspis lyktensis* and ?*P. minor* Heintz. In the latter species, which were regarded by Denison (1970) as persistently primitive, the medial longitudinal canals meet the pineal loop of the inter-orbital canal on the dorsal disc. *C. alocostomata* resembles *C. whitei* (see text-fig. 54) in the shape of the sub-rostral surface, the size of the pineal plate, and the presence of the pineal loop. It is distinguished from that species by its larger size, the longer medial extensions of its orbital plates, and by its larger cornual plates and dorsal spine.

*Canadapteraspis thymostomata* gen. et sp. nov.

Plate 16, figs. 1-3; text-figs. 46-48

*Diagnosis.* Dorsal shield approximately 110 mm long and half as wide. Ornament of laterally serrated dentine ridges with density of 7.5-10.0 per mm. Rostrum blunt, pre-oral field long with irregular excrescences on posterior margin. Posterior extensions of orbital plates extremely long.

*Holotype.* NMC 21362, incomplete dorsal shield prepared to show sub-rostral surface (Pl. 16, figs. 2, 3; text-figs. 46A, 48).

*Paratype.* NMC 21361, incomplete dorsal shield prepared to show ventral surface of lateral margin (Pl. 16, fig. 1; text-figs. 46B, 47, 49).

*Other material.* NMC 21363, incomplete orbital plate.

*Locality.* GSC 81053.

*Description.* The median length of the dorsal shield of the most complete specimen (NMC 21361) exceeds 110 mm; its maximum width is about half of that length. The inter-orbital distance is 40 mm, but the shield widens close behind the orbits (Pl. 16, fig. 1). The branchial opening, situated approximately 32 mm in advance of the postero-lateral corner of the shield, is bordered anteriorly by a cowl-like branchial plate and behind by a large cornual plate (text-fig. 46A). The cornual plates, which

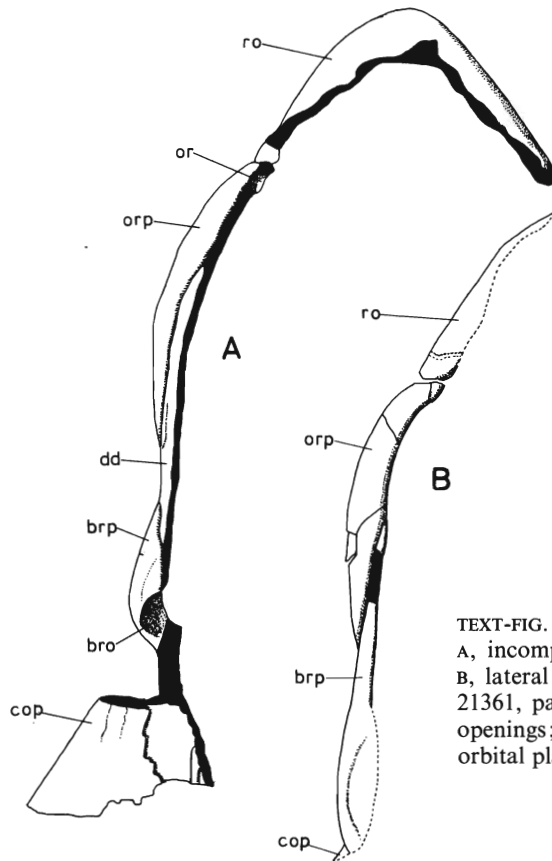

TEXT-FIG. 46. *Canadapteraspis thymostomata* gen. et sp. nov. A, incomplete dorsal shield (NMC 21362, holotype);  $\times 1$ . B, lateral margin of dorsal shield in ventral aspect (NMC 21361, paratype);  $\times 1$ . *brp*, branchial plate; *bro*, branchial openings; *cop*, cornual plate; *dd*, dorsal disc; *or*, orbit; *orp*, orbital plate; *ro*, rostrum.

#### EXPLANATION OF PLATE 16

Figs. 1-3. *Canadapteraspis thymostomata* gen. et sp. nov. 1, incomplete dorsal shield (NMC 21361, paratype),  $\times 1$  (see text-fig. 46B). 2, incomplete dorsal shield (NMC 21362),  $\times 1$  (see text-fig. 46A). 3, sub-rostral surface (NMC 21362, holotype),  $\times 2$  (see text-fig. 48).

Figs. 4, 5. *Canadapteraspis helostomata* gen. et sp. nov. 4, incomplete dorsal shield (NMC 21364, holotype),  $\times 1$ . 5, sub-rostral surface (NMC 21365, paratype),  $\times 4$  (see text-fig. 50).

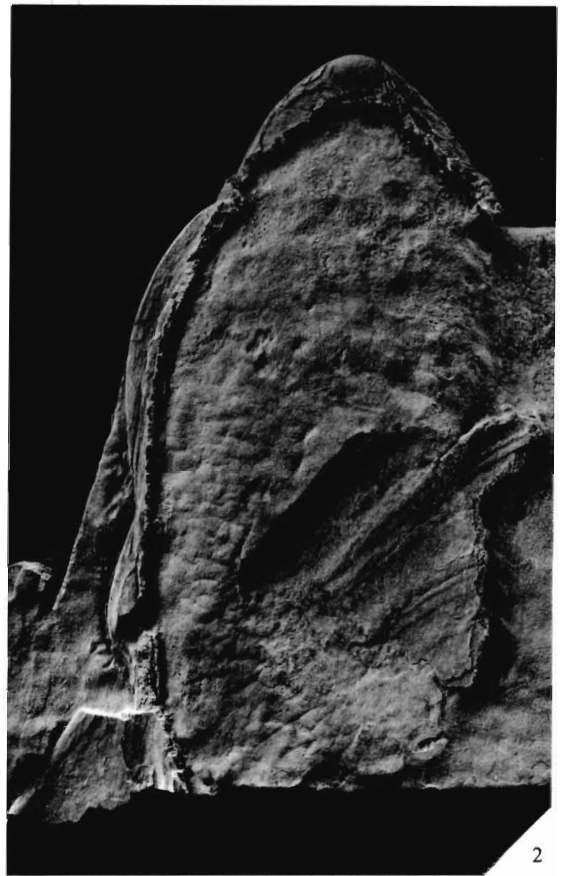

DINELEY and LOEFFLER, *Canadapteraspis*

are not preserved posteriorly, are broad and triangular (Pl. 16, figs. 1, 2); the base of attachment to the shield is approximately 35 mm long, the width of the plate being 20 mm. The posterior extensions of the orbital plates are extremely long, reaching into the posterior half of the shield and forming much of its lateral margin (text-fig. 46A, 47). The orbital plates are keeled, so that part of their posterior extension occupies a ventral position (text-fig. 46B). The branchial plate is reduced anteriorly to form a narrow, ventral wedge which expands posteriorly to form a cowl in front of the branchial opening.

The sub-rostral surface includes an elevated pre-oral field with irregularly orientated ridges (Pl. 16, fig. 3; text-fig. 48) which are, in part, continuous with those of the ventro-lateral face of the rostral plate; the dentine ridges of the ventro-lateral face are worn, but those of the pre-oral field retain distinct lateral serrations. On the posterior margin of the pre-oral field is a large, irregular, median excrescence, upon which dentine ridges are concentric about several points (Pl. 16, fig. 3; text-fig. 48). A separate ascending lamella is not distinguishable. Posterior to the pre-oral field, the ventro-lateral faces of the rostral plate are up to 8 mm wide; the broad indentations of their margins (Pl. 16, fig. 3) may be for the reception of oral plates.

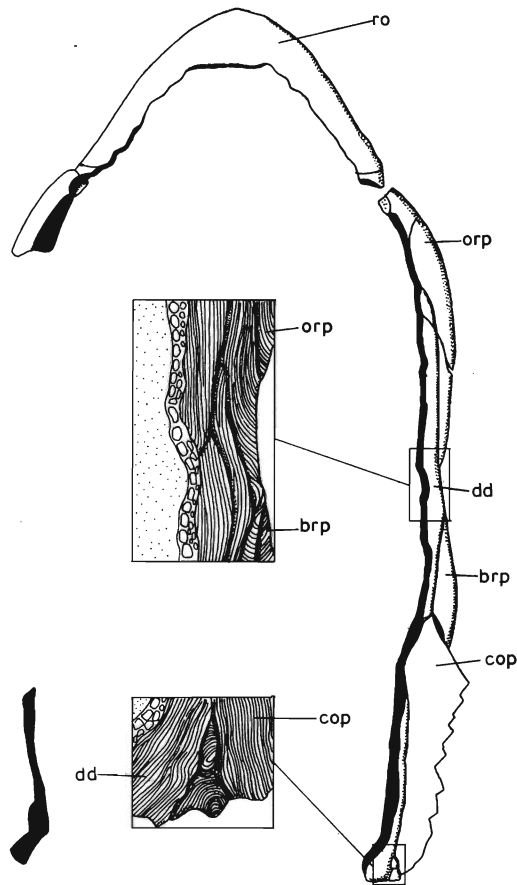

TEXT-FIG. 47. *Canadapterspis thymostomata* gen. et sp. nov., incomplete dorsal shield with inset detail of lateral margin (NMC 21361, paratype); plan view  $\times 1$ ; detail  $\times 3.75$ . *brp*, branchial plate; *cop*, cornual plate; *dd*, dorsal disc; *orp*, orbital plate; *ro*, rostral plate.

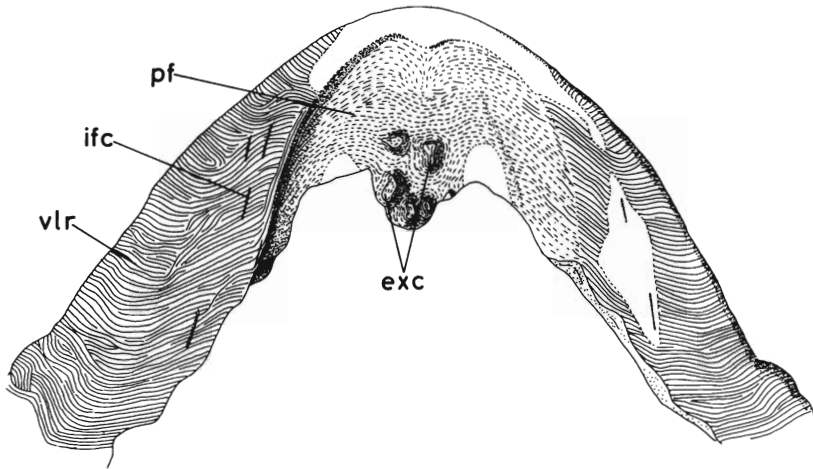

TEXT-FIG. 48. *Canadapterspis thymostomata* gen. et sp. nov., detail of sub-rostral surface (NMC 21362, holotype);  $\times 3.75$ . *exc*, excrescences on pre-oral field; *ifc*, pores of infraorbital canal; *pf*, pre-oral field; *vlr*, ventro-lateral face of rostrum.

As the two most complete specimens are preserved only peripherally, the pattern of the lateral line system is unknown.

Finely serrated dentine ridges with rather variable density ornament the rostrum 7.5 per mm, the cornual plates and the branchial plates 9 per mm. The pattern of ridges is extremely irregular near the margins of the plate (text-fig. 47), particularly at the posterior tip of the orbital plate. Two small plates (diameter 1.5 mm) are present between the cornual plate and the posterior margin of the dorsal disc of NMC 21361 (text-fig. 47).

*Remarks.* The presence of a pre-oral field with an ornament of dentine ridges confines this species to *Canadapterspis*. *C. thymostomata* is distinguished from other species within the genus by its large size and by the form of the pre-oral field; it is closest in appearance to *C. helostomata* from the same locality.

The irregularities of ridge pattern adjacent to the margins of the fused plates of this species may represent periodic additions to the growing plates. The two posterior plates, situated between the cornual plate and the posterior margin of the dorsal disc (text-fig. 47) may also be a feature of irregular growth; alternatively, they may represent separate centres of ossification. Small plates are developed in a similar position in some species of *Protaspis* but may correspond to cornual plates, which are otherwise absent (Denison 1970, p. 18).

The excrescences on the posterior margin of the pre-oral field of this species are so irregular that they must result from disease or damage. They may in some way be connected with the occluding of the oral plates; similar, but more regularly arranged, outgrowths are present on the posterior border of the pre-oral field of *C. helostomata*.

Large cornual plates are developed in many pteraspidids, probably to minimize rolling during swimming. Such extreme elongation of the orbital plates is not known in other genera; it is a feature shared with *C. helostomata*.

*Canadapterspis helostomata*

Plate 16, figs. 4, 5; text-figs. 49, 50

**Diagnosis.** Dorsal shield approximately 55 mm long and two-thirds as wide. Ornamentation of laterally serrated dentine ridges with a density of 14 per mm. Rostrum rounded, cornual plates large, posterior extensions of orbital plates extremely long. Sub-rostral surface with pre-oral field bearing irregular ridges and having a row of excrescences along its posterior border.

**Holotype.** NMC 21364, incomplete dorsal shield (Pl. 16, fig. 4; text-fig. 49).

**Paratype.** NMC 21365, rostral fragment prepared to show sub-rostral surface (Pl. 16, fig. 5; text-fig. 50).

**Locality.** GSC 81053.

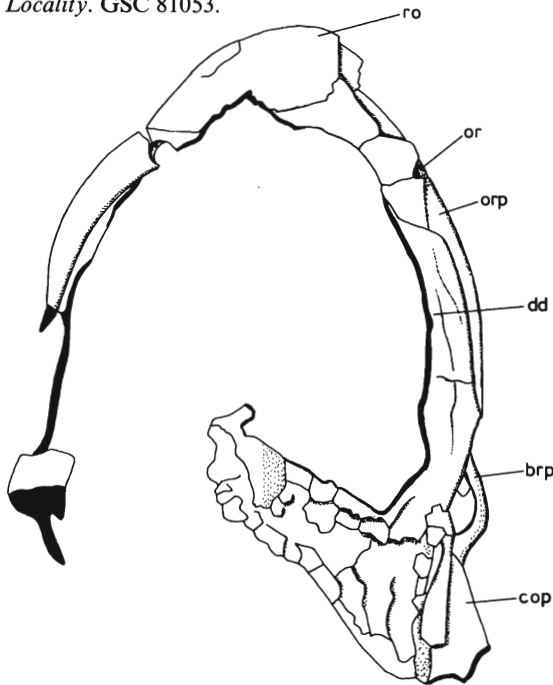

TEXT-FIG. 49. *Canadapterspis helostomata* gen. et sp. nov., incomplete dorsal shield (NMC 21364, holotype);  $\times 1$ . *brp*, branchial plate; *cop*, cornual plate; *dd*, dorsal disc; *or*, orbit; *orp*, orbital plate; *ro*, rostrum.

**Description.** The median length of the dorsal shield is at least 55 mm, its maximum width being 38 mm. The long posterior extensions of the orbital plates are longitudinally keeled, so that part of each has a ventral surface. As the orbital plates form much of the lateral margins of the shield, the branchial plates are reduced anteriorly and expanded behind to form cowls in front of the branchial openings (text-fig. 49). The latter lie approximately 13 mm in advance of the postero-lateral corners of the dorsal shield, being bounded posteriorly by large cornual plates. The base of attachment of the cornual plate to the dorsal shield is 13 mm long; although incomplete posteriorly, the plates are at least 6 mm wide.

The sub-rostral surface has a short pre-oral field, which is ornamented with fine, laterally serrated dentine ridges and bears a row of five excrescences on its posterior border (Pl. 16, fig. 5; text-fig. 50).

The holotype is too poorly preserved to show the path of the lateral line canals.

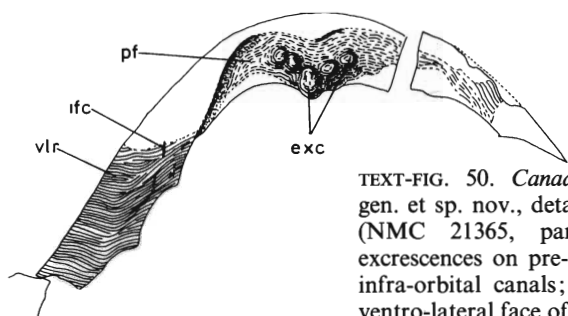

TEXT-FIG. 50. *Canadapterspis helostomata* gen. et sp. nov., detail of subrostral surface (NMC 21365, paratype);  $\times 3.75$ . *exc*, excrescences on pre-oral field; *ifc*, pores of infra-orbital canals; *pf*, pre-oral field; *vlr*, ventro-lateral face of rostrum.

*Remarks.* This species is referred to *Canadapterspis* because it has a pre-oral field with an ornament of dentine ridges. It is distinguished from other species by its small size, the extreme length of its orbital plates, the narrowness of its dentine ridges, and the shortness of its pre-oral field.

Although *C. helostomata* is smaller and relatively wider than *C. thymostomata*, the two species are similar. Both have elongated orbital plates, broad cornua, and excrescences on the pre-oral field. The possibility that these are growth stages of the same species is rejected, largely because of the differences in width of the dentine ridges.

The basic symmetry of the row of excrescences on the pre-oral field suggests that they are not a result of disease or damage. The median outgrowth is larger and more posteriorly placed than the two lateral pairs. They may have had some association with the oral plates. Tarlo (1961) believed similar structures on the posterior margin of the pre-oral field of *Rhinopteraspis cornubica* to be oral plates which had somehow adhered to the ascending lamella. This interpretation is far from convincing, especially since Tarlo's specimen is an internal mould, showing only a row of impressions (*ibid.*, pl. 2). It is probable that these elements are not separate plates but are excrescences like those developed in *C. helostomata*. This comparison is supported by the concentric arrangement of the ridges on these elements in both taxa. In *Rhinopteraspis* three pairs of lateral excrescences contrast to the two pairs of *C. helostomata*. The different pre-oral fields of these two species suggest that there is no close relationship between them. Possibly the small 'plates' at the posterior margin of the rostrum of *Althaspis* (*Cymripteraspis*) *leachi* (White 1960; Allen, Halstead and Turner 1968) also may be homologous with those of *Canadapterspis helostomata*.

?*Canadapterspis* sp. indet.

Plate 17, fig. 4; text-fig. 51B

*Material.* NMC 21372, incomplete dorsal shield.

*Locality.* GSC 81053.

*Description.* The dorsal shield is estimated to have been approximately 60 mm long and over 40 mm wide. The posterior extension of the orbital plate is long and keeled, forming much of the lateral margin of the dorsal shield and terminating close to the branchial opening (Pl. 17, fig. 4). The branchial opening, which is approximately



15 mm in advance of the postero-lateral margin of the dorsal disc, is bounded posteriorly by a falciform cornual plate and anteriorly by the cowl-like extension of the branchial plate (Pl. 18, fig. 4; text-fig. 51B). The base of attachment of the cornual plate is approximately 15 mm long, but the posterior tip of the cornual plate extends a further 11 mm beyond the postero-lateral corner of the shield; the maximum width of the cornual plate is 10 mm. Ornamentation is of serrated dentine ridges with an average density of eleven per mm. The lateral line canals of the dorsal shield form a closed network which is slightly smaller in extent than the area of the dorsal disc (text-fig. 51B).

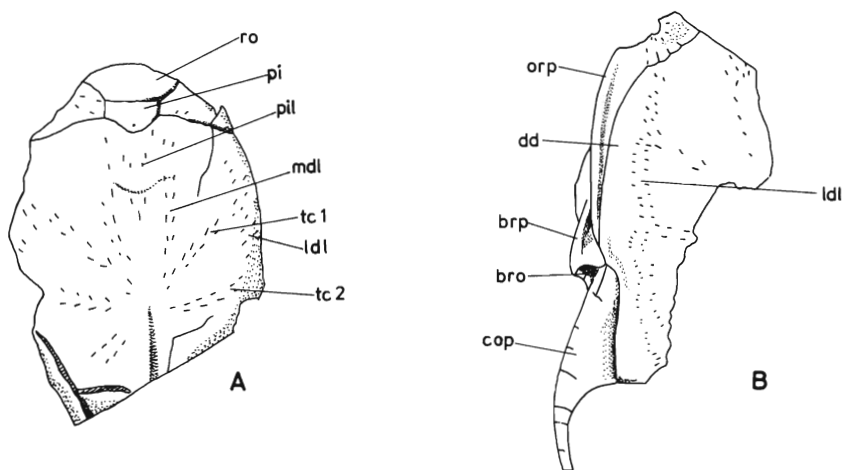

TEXT-FIG. 51. A, Pteraspidae indet., incomplete dorsal shield, showing lateral line pores (NMC 21455);  $\times 1$ . B, ?*Canadapterspis* sp. indet., incomplete dorsal shield, showing detail of branchial and cornual region (NMC 21372);  $\times 1$ . *bro*, branchial opening; *brp*, branchial plate; *cop*, cornual plate; *dd*, dorsal disc; *ldl*, lateral dorsal canal; *mdl*, medial dorsal canal; *orp*, orbital plate; *pi*, pineal plate; *pil*, pineal canal; *ro*, rostrum; *tc1*, *tc2*, transverse commissures.

*Remarks.* This form resembles *C. alocostomata* in size and in the shape of the cornual plates. The posterior extensions of the orbital plates are, however, longer than those of that species, more closely resembling the orbital plates of *C. thymostomata* and *C. helostomata*. Since the only specimen is incomplete, it is tentatively referred to *Canadapterspis*.

#### EXPLANATION OF PLATE 17

- Fig. 1. Pteraspidae indet. Incomplete dorsal shield (NMC 21455),  $\times 1.75$ .  
 Figs. 2, 3. *Canadapterspis alocostomata* gen. et sp. nov. 2, sub-rostral surface (NMC 21457, paratype),  $\times 1.75$  (see text-fig. 44). 3, incomplete dorsal shield (NMC 19993, holotype),  $\times 2$ .  
 Fig. 4. *Canadapterspis* sp. indet. Incomplete dorsal shield (NMC 21372),  $\times 2$  (see text-fig. 51B).

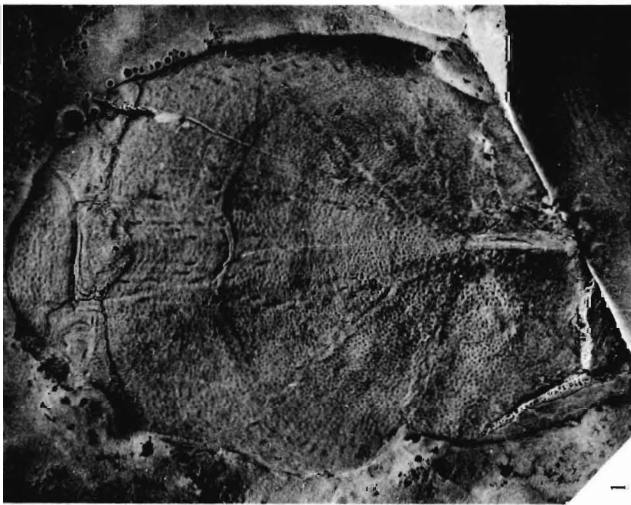
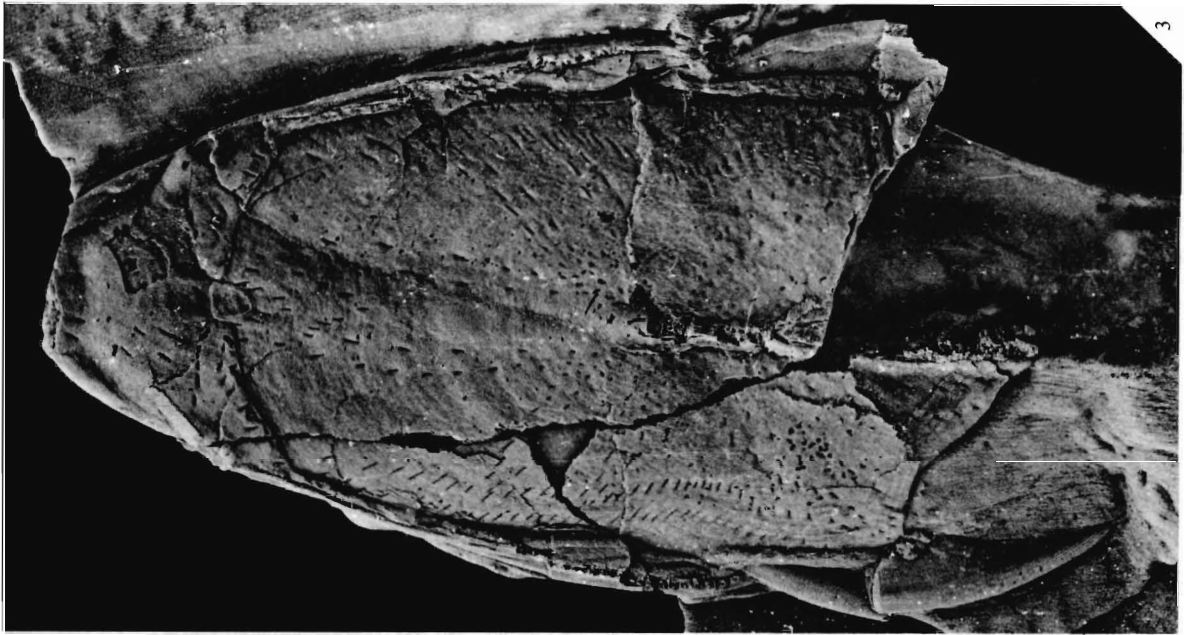

DINELEY and LOEFFLER, *Canadapteraspis*

## Pteraspidinae indet.

Material too fragmentary, or too poorly preserved, to warrant full description is listed by locality:

*GSC locality 69014*

NMC 21349. A large, incomplete dorsal disc, over 55 mm long and with fourteen ridges per mm.

NMC 21350. A small, incomplete dorsal shield estimated to have been approximately 25 mm long and 14 mm wide. Pineal plate oval and not in contact with orbital plates; sub-rostral surface incomplete but apparently lacking a pre-oral field and covered with longitudinal dentine ridges (text-fig. 52).

NMC 21351. An orbital plate, with an extremely long, keeled, posterior extension (text-fig. 53B).

NMC 21352. A poorly preserved dorsal shield; pineal plate small, median extensions of orbital plates not in contact with pineal plate. The inter-orbital lateral line canal forms a pineal loop on the anterior part of the dorsal disc. The rostrum is moderately elongated and the dorsal spine well developed (text-fig. 53A).

NMC 21353–21360. Eight indeterminate fragments.

NMC 21378, 21379, 21456. Isolated scales.

NMC 21431. A ventral shield and squamation, very poorly preserved.

NMC 21497. Indeterminate fragments associated with scales.

NMC 19958, 19975–19990. Seventeen ventral shield fragments of various sizes.

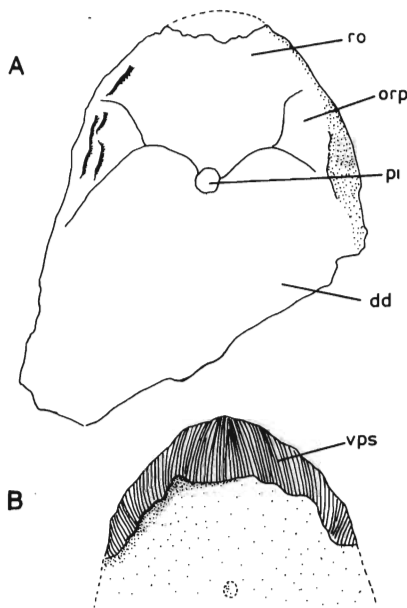

TEXT-FIG. 52. Pteraspidinae indet., incomplete dorsal shield (NMC 21350);  $\times 3.75$ . A, dorsal view. B, ventral view of sub-rostral surface, showing pattern of dentine ridges. *dd*, dorsal disc; *orp*, orbital plate; *pi*, pineal plate; *ro*, rostral plate; *vps*, ventral pre-oral surface.

*GSC locality 69017*

NMC 21369. An indeterminate fragment, eight dentine ridges per mm.

NMC 21370. An indeterminate plate fragment, in which dentine ridges have become detached from deeper layers.

NMC 21371. A large dorsal spine, 57 mm long.

NMC 21454. A poorly preserved shield fragment with short orbital and long branchial plates; dentine ridges twelve to fourteen per mm.

*GSC locality 81057*

Numerous small fragments present in residues after solution in 15% acetic acid.

*GSC locality 81052*

NMC 21366. An incomplete dorsal shield.

NMC 21368. An incomplete ventral shield.

*GSC locality 81053*

NMC 21373. A ventral shield (58  $\times$  28 mm) with eight ridges per mm.

NMC 21374. A ventral shield fragment.

NMC 21375–21376. Indeterminate shield fragments with four to five ridges per mm.

NMC 21377. An indeterminate rostral fragment.

NMC 21455. An incomplete, large dorsal shield; median extensions of orbital plates are in contact with a wide pineal plate; the inter-orbital canal extends on to the anterior part of the dorsal disc as a pineal loop (Pl. 18, fig. 1; text-fig. 51A).

## GENERAL COMMENTS ON THE PTERASPIDIDAE

*Classification within the Pteraspidae*

In an attempt to rationalize pteraspidid classification, White (1956) used the features of the rostral region as criteria distinguishing four subgenera of *Pteraspis*. Later (1960, 1961), he restored one subgenus and added two more to a classification based on European material. Following a study of the sub-rostral surfaces of Podolian pteraspidids, Stensiö (1958) named seven new genera (equivalent to White's subgenera). He subsequently (Stensiö 1964) listed a total of nineteen genera but, by omitting to define them adequately, made comparison with other material difficult. To overcome this problem, Tarlo (1961) combined features of White's and Stensiö's schemes in an outline classification wherein the number of genera was reduced to ten.

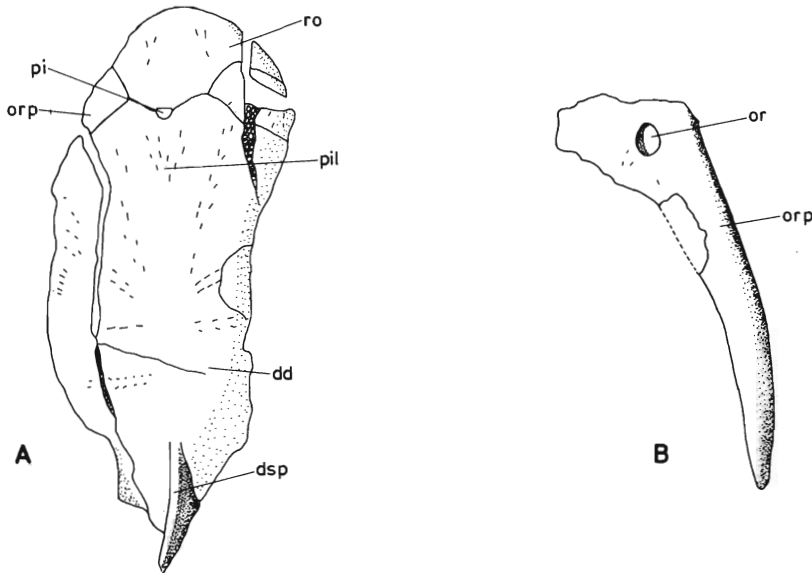

TEXT-FIG. 53. Pteraspidae indet. A, incomplete dorsal shield (NMC 21352);  $\times 1.25$ . B, orbital plate (NMC 21351);  $\times 1.875$ . *dd*, dorsal disc; *dsp*, dorsal spine; *or*, orbit; *orp*, orbital plate; *pi*, pineal plate; *pil*, pineal canal; *ro*, rostral plate.

Tarlo (1961) regarded the structure of the underside of the rostrum as of great taxonomic importance, using it to distinguish three separate evolutionary lineages; he considered that there had been parallel evolution within the family, both broad-carapaced and long-snouted forms having been achieved independently in separate lineages.

Denison (1967a) criticized this reliance on the rostral structure; he considered that the elongate rostrum was a rapidly evolving, highly adaptive character and, like Tarlo (1961), concluded that it may have developed more than once as a result of parallel evolution. He cited undescribed material from Wyoming as evidence for the parallel evolution of sub-rostral structures such as the ventral lamina and the pre-oral field. On the basis of an evaluation of numerous characters, Denison divided

the family into four genera (*Pteraspis*, *Rhinopteraspis*, *Protaspis*, and *Doryaspis*) and five subgenera (three of *Pteraspis* and two of *Protaspis*). After more detailed study of the pteraspidids from Wyoming and Utah, Denison (1970) produced a scheme whereby the family Pteraspidae was divided into two subfamilies, the Pteraspidae (containing *Protopteraspis*, *Pteraspis*, *Althaspis*, *Rhinopteraspis*, *Protaspis*, *Oreaspis*, *Lampraspis*, and *Psephaspis*) and the *Doryaspidae* (containing only *Doryaspis*); the genus *Protaspis* was further subdivided into six subgenera. This classification attached less significance to rostral structure in distinguishing genera than did that of Stensiö (1958, 1964) and Tarlo (1961), and more significance to the form and position of the branchial openings. Although Denison's (1970) scheme is accepted as providing the basis for a reasonably concise framework for pteraspidid classification, the following modifications are proposed.

Denison described the pre-oral field as 'a clearly defined area elevated above the rest of the rostral surface and lacking ornamentation of dentine ridges' (1970, p. 3). He did not differentiate between those pteraspidids in which the elevated area was lacking and those in which it was present but ornamented with dentine ridges. Within his (1970) genus *Althaspis* were included *Podolaspis* (*Althaspis*) Zych. Also included in *Althaspis* was a species from Nova Scotia which, until preparation of its sub-rostral surface showed it to be covered in irregular dentine ridges, had been included in the primitive genus (or subgenus) *Simopteraspis* (equivalent to *Protopteraspis* of Denison 1970). A diagram of the sub-rostral surface of the species (Denison 1970, fig. 3; reproduced as text-fig. 54A in this work) shows part of the sub-rostral surface to be elevated as a distinct pre-oral field. Similar elevated pre-oral fields, with an ornament of dentine ridges, are also present in *Loricopteraspis althi* (Stensiö) and in *Brotzenaspis pteraspidoides* (Stensiö), as well as in *Pteraspis* sp. (Stensiö 1958, figs. 152a and b, 149a and b), and in the three new species from the District of Mackenzie.

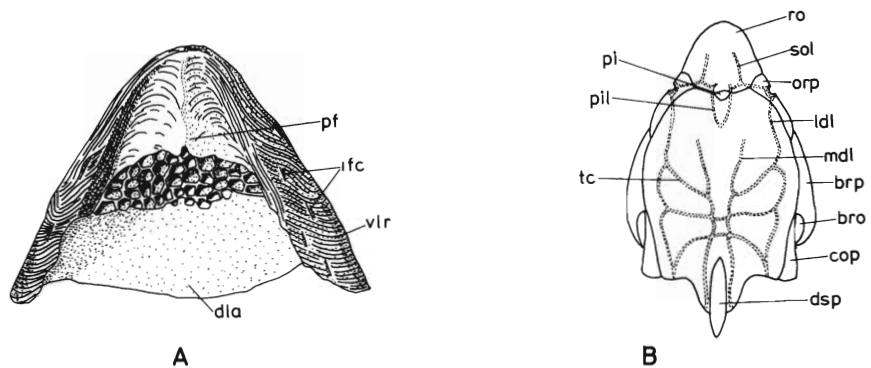

TEXT-FIG. 54. *Canadapteraspis whitei* (Denison). A, sub-rostral surface;  $\times 3$  (from Denison 1970, fig. 3); B, reconstruction of dorsal shield;  $\times 0.75$  (from Denison 1955, fig. 10). *bro*, branchial opening; *brp*, branchial plate; *cop*, cornual plate; *dla*, ventral surface of dorsal lamina; *dsp*, dorsal spine; *ifc*, pores of infra-orbital canal; *ldl*, lateral dorsal canal; *mdl*, medial dorsal canal; *orp*, orbital plate; *pf*, pre-oral field; *pi*, pineal plate; *pil*, pineal canal; *ro*, rostrum; *sol*, supra-orbital canal; *tc*, transverse commissure; *vlr*, ventro-lateral face of rostrum.

In view of these differences in rostral structure, it is proposed that *Podolaspis* (*Althaspis*) *Zych* and *Pteraspis* (*Cymripteraspis*) *White* (including *Pseudopteraspis* *Stensiö*) should be retained within the genus *Althaspis*, but that *Brotzenaspis pteraspidooides*, *Loricopteraspis althi*, and *Pteraspis (Simopteraspis) whitei* should be removed. The revised genus *Althaspis*, the type species of which is *A. samsonowiczii* Tarlo (text-fig. 55A), would be defined as follows:

Moderate to large pteraspidinids with elongate rostrum, the ventral surface of which lacks a pre-oral field and is ornamented with transverse dentine ridges. Branchial openings placed well in advance of the postero-lateral corners of the dorsal shield and bounded by branchial and cornual plates. Pineal plate wide, adjoining narrow, median projections of orbital plates.

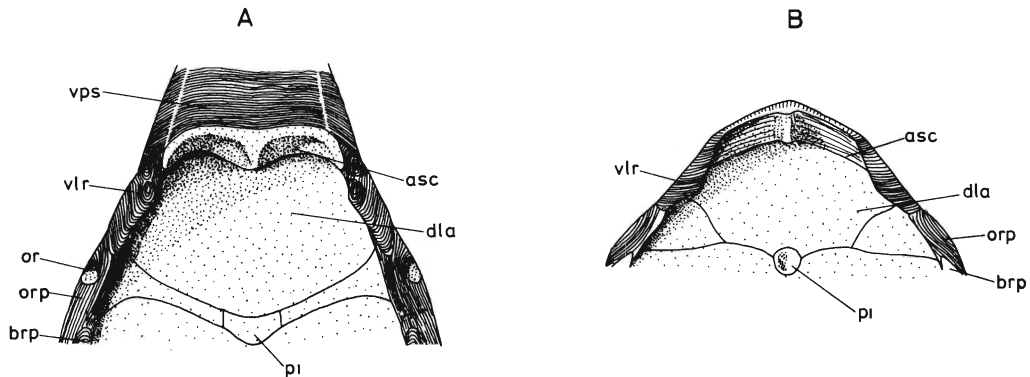

TEXT-FIG. 55. Sub-rostral surfaces. A, *Althaspis samsonowiczii*;  $\times 1.15$  (from Stensiö 1964, fig. 59); B, *Protopteraspis primaeva*;  $\times 1.35$  (from Stensiö 1964, fig. 43). *asc*, ascending lamella; *brp*, branchial plate; *dla*, ventral surface of dorsal lamina; *or*, orbit; *orp*, orbital plate; *pi*, pineal plate; *vlr*, ventro-lateral face of rostrum; *vps*, ventral pre-oral surface.

A new genus, *Canadapteraspis*, is proposed for the reception of the three new species from the District of Mackenzie, and to include *P. (Simopteraspis) whitei* Denison. Features common to the four species are considered adequate to define this genus (see p. 112). *L. althi* (Stensiö), *B. pteraspidooides* (Stensiö), and *Pteraspis* sp. (Stensiö 1958, figs. 152a and b, 149a and b), although resembling *Canadapteraspis* in sub-rostral structure, are otherwise too inadequately known to be included in that genus. Acknowledging possible parallel evolution of rostral structures, it is considered inadvisable to attempt to classify specimens without adequate parts or fragments of the rostra.

The two best-known species of *Canadapteraspis*, *C. whitei* (Denison) and *C. alocostomata*, show greatest similarity to *Protopteraspis* (*sensu* Denison 1970) and particularly to those species which were referred to *Pteraspis (Simopteraspis)* by White (1950b). As in these species, which are the earliest known representatives of the family, the branchial openings of *Canadapteraspis* are placed well in advance of the postero-lateral corner of the shield and bounded by well-developed branchial and cornual plates; the pineal plate is small and the inter-orbital lateral line canal forms a pineal loop on the anterior part of the dorsal disc. Thus, in spite of the difference in

rostral structure, there appear to be more similarities between *Canadapteraspis* and *Pteraspis* (*Simopteraspis*) White than between the latter and *Zascinaspis* Stensiö, both of which were regarded by Denison (1970) as synonyms of *Protopteraspis* Leriche. *Zascinaspis* Stensiö is characterized by a broad pineal plate, deep ascending lamella, and an inter-orbital lateral line canal which does not form a pineal loop on the anterior part of the dorsal disc (Tarlo 1961; Denison 1970). Since the branchial region of *Zascinaspis* is poorly known, and there is a possibility that parallelism is involved in the similarity of the rostral region, the inclusion of *Zascinaspis* Stensiö within *Protopteraspis* is questioned. Although Denison (1970) considered that the differences could be correlated with size, *Zascinaspis* and *Protopteraspis* are not considered synonymous here. The revised genus *Protopteraspis*, the type species of which is *P. gosseleti* Leriche, is defined as follows:

Small pteraspidinids with short, bluntly rounded rostrum, small, triangular pineal plate widely separated from the orbital plates. Sub-rostral surface short, lacking a pre-oral field and having a narrow ascending lamella. Branchial openings placed in advance of the postero-lateral corners of the dorsal shield and bounded by branchial and cornual plates. Inter-orbital lateral line canal forming pineal loop on dorsal disc.

#### *Growth in the Pteraspidae*

Denison (1973) recently provided a review of past studies on growth in the Pteraspidae. Previous work showed that, during the early stages of development of the shield, the lateral dorsal sensory canals lay in the soft tissue between the plates (Zych 1931) and that the shield grew by stages even after these canals had been incorporated into the dorsal disc (White 1958). White (1958) also demonstrated that there was less growth after incorporation of the lateral dorsal sensory canals in early pteraspids than in later members of the family.

Stensiö's (1958, 1964) interpretations of pteraspid growth are rejected because they are based entirely on ridge pattern and take no account of juvenile stages.

Denison's (1973) studies of juvenile and adult *Protaspis* show that there was an early unarmoured larval stage. When the shield and scales were first formed, they consisted only of thin dentine and aspidin, but with growth they increased in area by marginal addition and in thickness by addition to the superficial layer and formation of the reticular, cancellous, and basal layers. Only at maturity did growth cease and the plates become fused. Repair to damage or disease of the shield was achieved in *Protaspis* by the production of blisters of secondary dentine and by the infilling of the cancellous and reticular layers with dentine.

Denison (1973) pictured the concentric ridge pattern of the Pteraspidae (and also the pattern of the Cyathaspidae) as an indication of soft structures which existed in the skin prior to mineralization. He visualized the intercostal grooves as concentric invaginations around centres of growth, and suggested that they may have housed sensory organs; the ridges he interpreted as rows of papillae, on whose crests dentine was subsequently formed.

White (1973) has demonstrated that the ridges which mark growth stages in *Belgicaspis crouchi* are due to brief periods of excessive growth rather than to periods of rest.

The pteraspids from the Mackenzie Mountains do not reveal any features significant to growth studies. One dorsal and one ventral disc (NMC 21455, 19985) have distinct growth lines, but neither are complete nor identifiable. No indication of secondary dentine formation is apparent. The irregular excrescences on the margins of the pre-oral fields of *Canadapteraspis thymostomata* and *C. helostomata* must have been present in the soft tissue prior to calcification.

#### *Phylogeny and evolutionary relationships of the Pteraspidae*

Although Denison's (1964) reasons for supposing that the Pteraspidae were derived from the Cyathaspidae are fairly convincing, additional knowledge shows that the same arguments can be used to greater effect in demonstrating a close relationship between the Traquairaspidae and the Pteraspidae.

1. The known stratigraphic ranges of the two groups favour their derivation from one another. The Traquairaspidae range from the Wenlockian to the Early Dittonian, by which time the Pteraspidae were present in the Anglo-Welsh borders (Ball and Dineley 1961).

2. The plates of the pteraspid headshield are more closely comparable to the dorsal disc, orbital and branchio-cornual plates of some traquairaspids than to the epitega of the cyathaspids.

3. According to White (1946, p. 228), the microstructure of the shield of *Traquairaspis* is 'in agreement with that in cyathaspids and certain pteraspids in which the reticular layer is poorly developed'.

4. Although certain cyathaspids approach pteraspids in one character or another (Denison 1964, p. 465), this is equally true of some traquairaspids; cornual plates and an erect dorsal spine are present in two species described by Broad (1971).

5. The pteraspid lateral line system is easily derived by minor modifications of the simple pattern of cyathaspids (Denison 1964, p. 465), but it can more easily be derived from that of various traquairaspids.

Although certain traquairaspids described by Broad (1971) approach the pteraspid condition in having cornua and a dorsal spine, the facts that the spine is not a separate element and that the lateral line system is an anastomosing network suggest that, rather than being ancestral pteraspids, they offer an example of parallelism.

*Torpedaspis*, a large poraspidinid with a 'pteraspid-like' rostral region, was regarded by Broad and Dineley (1973) as an advanced cyathaspid and cited as further evidence for the close relationship of the Pteraspidae and the Cyathaspidae, as proposed by Denison (1964). *Torpedaspis* is, however, a member of the Poraspidae and, as such, lacks the epitegal divisions which Denison (1964) compared with the pteraspid plates. This, together with the fact that the sub-rostral surface of the earliest pteraspids was unlike that of *Torpedaspis*, suggests that this cyathaspid exhibits parallelism rather than a close relationship with the Pteraspidae.

Obruchev (1967) also noted the similarities between the Pteraspidae and the Traquairaspidae, but considered *Traquairaspis* to be 'an early offshoot of the pteraspid stock', a view which lacks stratigraphic support. Halstead (1973) has proposed an evolutionary scheme in which the cyathaspids and the pteraspids are independently derived from 'tesselated ancestors', *Traquairaspis* being considered as



intermediate between the psammosteids and the pteraspids. The similarities in morphology and microstructure between the Pteraspidae, Cyathaspidae, and Traquairaspidae are difficult to explain in these terms, and the evolutionary scheme proposed by Halstead (1973, fig. 12) is not supported by stratigraphic evidence.

It is suggested here that the Pteraspidae may have been derived from the Traquairaspidae prior to the Late Downtonian, and that the relationships of the families Traquairaspidae, Pteraspidae, Cyathaspidae, and Corvaspididae are close.

Tarlo (1961) used the structure of the underside of the pteraspid rostrum to distinguish three evolutionary lineages, all derived from a common primitive ancestor such as *Protopteraspis*, and within which, he considered, parallel evolution took place, both long-snouted and the broad-carapaced conditions having been independently achieved in different lines. In the *Zascinaspis*-*Protaspis* lineage, which led to one of the broad-carapaced forms, there had been little change in the rostrum; in the *Althaspis* lineage, elongation of the snout had been achieved by addition to the posterior margin of the rostral plate. The third lineage, in which both long-snouted and broad-carapaced forms were supposed to have developed, was characterized by the presence of a pre-oral field.

Describing pteraspids from western U.S.A., Denison (1967a, 1970) claimed that many rostral structures (including the pre-oral field) had been independently achieved in the European and American pteraspids. He also considered that there had been parallel evolution of branchial structures within the two groups. Features in the ontogenetic development of *Lampraspis* suggested to him (1970) that that genus was derived from a *Protaspis*-like pteraspid, and that the *Pteraspis*-like arrangement of its branchial openings was secondary both phylogenetically and ontogenetically. This left Denison in some doubt as to whether the European subgenera of *Protaspis* (*Europrotaspis* and *Gigantaspis*) were closely related to the American subgenera (*Protaspis*, *Cosmaspis*, *Eucyclaspis*, and *Cyrtaaspidichthys*) or whether the similarity in their branchial openings was a result of parallel evolution. He did, however, consider the American protaspids to be closely related both to one another and to the other American genera (*Psephaspis*, *Lampraspis*, and *Oreaspis*). Denison (1960) thought of *Pteraspis carmani* as ancestral to the American protaspids, comparing it with the subgenera *Brachipteraspis* Brotzen and *Protopteraspis* Leriche. It was subsequently included with *Brachipteraspis* in *Zascinaspis* (Stensiö 1958; Tarlo 1961), the latter genus being regarded by Denison (1970) as synonymous with *Protopteraspis*. In view of the possibility of parallel evolution of the rostral region, differences in morphology of the shield and the sensory canal system have been used above (p. 132) to distinguish *Protopteraspis* and *Zascinaspis*; the relationship between the two genera is uncertain, as are the affinities of the protaspids.

Here it is suggested that *Canadapteraspis* is closely related to *Protopteraspis*, having been derived from it by the development of a pre-oral field. Further attempts to elucidate evolutionary relationships within the family should include a study of the largely undescribed pteraspid collections from Vestspitsbergen, Podolia, and Arctic Canada.

*Distribution of the Pteraspidae*

The Pteraspidae make their first undisputed appearance at the base of the Dittonian of the Anglo-Welsh borders (Ball and Dineley 1961), the latest member of the family surviving into the Middle Devonian in western U.S.A. (Denison 1968, 1970). At various times in their history, members of the Pteraspidae existed in eastern and western Europe, Vestspitsbergen, and North America. Although large collections of pteraspids have been made from these areas, much of the material still awaits description.

The distribution of the Pteraspidae is summarized in text-fig. 56. The lowest Dittonian of the Anglo-Welsh borders is characterized by the primitive pteraspid, *Protopteraspis* (White 1950a). The latter genus appears at approximately the same time in Vestspitsbergen (White 1961) and in France (White 1956); the closely related genus, *Canadapteraspis*, apparently occurs simultaneously in eastern Canada (Denison 1952; Dineley 1967) and is also found in western Canada (this work).

Later in the Dittonian, pteraspids dominate the vertebrate faunas, yet remain a conservative group. Typical of this period are *Pteraspis* and *Belgicaspis*, occurring in Britain (White 1950; Ball and Dineley 1961), western Europe (White 1956), and Podolia (Obruchev and Karatajute-Talimaa 1967). *Belgicaspis*, alone, has been reported from Lithuania (Obruchev and Karatajute-Talimaa 1967) and eastern Canada (Dineley 1967). In Podolia, *Belgicaspis* and *Pteraspis* occur together with *Zascinaspis* and *Loricopteraspis*; pteraspids of similar age undoubtedly occur in the Ben Nevis Formation of Vestspitsbergen (Foyne and Heintz 1963).

The uppermost Dittonian of the Anglo-Welsh borders is characterized by the presence of *Althaspis* and *Protaspis* (White 1950a, 1961), both of which are also known from Podolia and western Europe (Halstead and Turner 1973). Probably of similar age (Early Siegenian) are strata in Wyoming, Utah, and Idaho (western U.S.A.), which have yielded a number of species of *Protaspis* (referred to the subgenera *Cosmaspis*, *Eucyclaspis*, *Cyrtaspidichthys*, and *Protaspis*) together with the related *Lampraspis* and *Oreaspis* (Denison 1970); *Psephaspis*, originally thought to be a drepanaspid (Ørvig 1961), first appears in the Siegenian of this area and continues up into the Middle Devonian (Denison 1968). Denison (1960) regarded *Pteraspis carmani* from the Holland Quarry Shale of Ohio as being closely related and probably ancestral to *Protaspis*, admitting that its generic reference was arbitrary; on the basis of rostral structure, the species was subsequently referred by Tarlo (1961) to *Zascinaspis* and by Denison (1970) to *Protopteraspis*, but this is questioned (p. 132).

*Rhinopteraspis* marks the beginning of the Breconian of the Anglo-Welsh borders and is found in strata of similar age in France, Belgium, Germany (White 1956), and Lithuania (Obruchev and Karatajute-Talimaa 1967); it survived into the Middle Emsian in Poland (Tarlo 1958) and SW. Germany (White 1956). *Rhinopteraspis* has not been recorded from Vestspitsbergen, where the Kapp Kjeldsen Division belongs to the later part of the Downtonian and possibly also to the earliest part of the Dittonian; the pteraspids of the Chortkov Horizon are not the small primitive types, which are characteristic of the earliest Dittonian. Turner (1973) follows Obruchev and Karatajute-Talimaa (1967) in correlating the Borshchov Horizon with the upper part of the Downtonian (*sensu* Allen and Tarlo 1963), i.e. with the Late

Silurian. If the Borshchov Horizon is Devonian, as its invertebrate fauna suggests, the incoming of the *Turinia pagei* assemblage, which is regarded by Turner (1973) as being equivalent to the base of the zone of *Monograptus uniformis*, should occur at the base of the Borshchov Horizon and not the base of the Chortkov Horizon as shown by Turner (1973, fig. 11).

The ostracoderm fauna of the Old Red Group of Podolia is in need of revision. Obruchev and Karatajute-Talimaa (1967) noted that the ostracoderm assemblages of the divisions proposed by Balabay (1959, 1960) were almost identical and that many of the species were also common to the Chortkov Horizon. They suggested correlation of the Old Red Group with the upper part of the *couchi-rostrata* and the *leachi* zones of the Dittonian. If this is accepted, the Chortkov Horizon must be equivalent to the lower part of the *couchi-rostrata* Zone and perhaps also to part of the *leathensis* Zone of the Anglo-Welsh succession (see text-figs. 56, 78).

	ANGLO WELSH CUVETTE	RHINELAND	POLAND	LITHUANIA & LATVIA	VEST- SPITSBERGEN	WYOMING	UTAH	OHIO	PRINCE OF WALES IS.
EMSIAN	BRECONIAN	SEE WHITE (1956) FOR STRATIGRAPHY	PLACODERM SST. <i>Rhinopteraspis</i>	<i>Rhinopteraspis</i>	WOOD BAY FORMATION <i>?Pteraspis</i> <i>Doryaspis</i>	BEAR TOOTH BUTTE FM. <i>Lampraspis</i> <i>Oreaspis</i> <i>Protaspis</i>	WATER CANYON FORMATION <i>Psephospis</i>	HOLLAND QUARRY SH. <i>Zacinaspis</i>	PEEL SOUND FORMATION Undescribed <i>Pteraspis</i> idae
SIEGIENIAN	<i>Rhinopteraspis</i> <i>Allhaspis</i> <i>Protaspis</i>		PODOLIA <i>Allhaspis</i> <i>Belgicaspis</i> <i>Pteraspis</i> <i>Zacinaspis</i>	SESUVI FM.	<i>Protaspis</i>		NOVA SCOTIA		
GEDINNIAN	DITTONIAN	<i>Pteraspis</i> <i>Belgicaspis</i>	OLD RED <i>Belgicaspis</i> <i>Zacinaspis</i> <i>Protaspis</i> <i>Loricopteraspis</i> <i>Pteraspis</i>	<i>Belgicospis</i>	BEN NEVIS FM. <i>Protaspis</i>	KNYODART FORMATION <i>Belgicospis</i>	DISTRICT OF MACKENZIE	DISTRICT OF MACKENZIE	
	DOWNTONIAN	<i>Protopteraspis</i>	CHORTKOV <i>Protopteraspis</i>	STONISKYAI SUITE	FRAENKELRYGGEN <i>Protopteraspis</i>				<i>Protopteraspis</i>
PRIDOLIAN			SKALA (part) BORSHCHOV	MINIJA   JURA   TILZE					

TEXT-FIG. 56. Distribution of the Pteraspidae.

### *Vestspitsbergen*

On the chart (text-fig. 56) correlation of the Vestspitsbergen sequence with the Anglo-Welsh Lower Old Red Sandstone broadly follows the scheme of Friend (1961), with the unit terms modified after Friend *et al.* (1966). Following Ørvig (1969a), the Fraenkelryggen Formation is regarded as equivalent to the *Traquairaspis* and *Protopteraspis leathensis* zones only, the boundary between the Downtonian and Dittonian equivalents falling within or just above the *primaeva* Beds. The Wood Bay Formation contains *Protaspis* (*Gigantaspis*) and two small, enigmatic pteraspids. The latter, originally questionably referred to *Pteraspis* (Heintz 1960), were subsequently used to establish *Grumantaspis* (Obruchev 1964) and *Ennosveaspis*

(Stensiö 1964), genera which Denison (1970) considered to be inadequately characterized. The overlying Lyktan faunal division of the Wood Bay Formation contains the aberrant *Doryaspis*.

Pending the description of pteraspids from Vestspitsbergen and Canada, and the revision of the Podolian pteraspids, speculation about the evolution and migration of the family can only be tentative. The diversity of the Podolian pteraspids may be more apparent than real, and the study of species from Vestspitsbergen and Canada may clarify relationships between the faunas of Europe and North America.

It is already apparent that the pteraspids underwent a period of evolutionary radiation in the early and middle Dittonian; the pteraspid faunas of eastern Canada, Britain, France, Germany, Podolia, Vestspitsbergen, and the Baltic have much in common, and it is probable that there were few barriers to migration. Although pteraspids occur in the Early Dittonian (and possibly also the Late Silurian) of northern Canada, the family apparently did not reach western U.S.A. until the Late Dittonian; there they underwent a second period of evolutionary radiation. Somewhat aberrant pteraspids occur in strata of similar age in Vestspitsbergen and, if the similarity of the Vestspitsbergen *Protaspis* (*Gigantaspis*) to the American protaspids is the result of a close relationship (see p. 132), then an early connection between the two areas is suggested. The difference between the later faunas implies that development may then have continued in isolation. If the species from Ohio is considered ancestral to the American protaspids (Denison 1960) then its origins become crucial in any discussion of evolutionary relationships and migratory routes.

#### *Biostratigraphic significance of the Pteraspidae*

In a scheme for the zonation of the Lower Old Red Sandstone of the Anglo-Welsh borders (White and Toombs 1948; White 1950a), three of the zones are based on members of the Pteraspidae, their replacement of the Traquairaspidae being used to mark the boundary between the Downtonian and Dittonian Stages. The base of the Dittonian is characterized by the primitive *Protopteraspis leathensis*, the greater part of the rest of the Dittonian by *Belgicaspis crouchi* and *Pteraspis rostrata*; the Senni Beds of the succeeding Breconian Stage contain *Rhinopteraspis dunensis* (White 1950b). The gap between the *crouchi-rostrata* Zone and the *dunensis* beds is locally filled by a fauna with *Althaspis leachi* (Ball and Dineley 1952).

A similar succession of pteraspids has been recognized in France, Belgium, and Germany (White 1956, 1960; Schmidt 1959) and in Lithuania and Latvia (Obruchev and Karatajute-Talimaa 1967). The pteraspid fauna of Vestspitsbergen remains to be studied in detail, but it appears that the earliest forms, from the upper half of the Fraenkelryggen Formation and the base of the Ben Nevis Formation, belong to the primitive genus *Protopteraspis* (White 1950b); larger undescribed pteraspids, including *Protaspis*, occur throughout the Ben Nevis Formation (Foyn and Heintz 1943). The overlying Wood Bay Formation contains the aberrant *Doryaspis* together with *Protaspis* (*Gigantaspis*) and two enigmatic pteraspids described by Heintz (1960); the two lower divisions of the formation proposed by Foyn and Heintz (1943) are characterized by the guide fossils *Protaspis* (*Gigantaspis*) and *Doryaspis*.

Balabay (1960) discerned three zones in the Old Red Group of Podolia, based almost entirely on species of pteraspid (see Zych 1931; Stensiö 1958, 1964), but

Obruchev and Karatajute-Talimaa (1967) found that the fauna of these three zones was almost identical and differed little from that of the underlying Chortkov Horizon.

Dineley (1967) has reported a succession of pteraspids closely resembling that of the Anglo-Welsh borders in the Knoydart Formation of Nova Scotia; a rather small, primitive species, *Canadapteraspis whitei*, occurs closely above the highest known occurrence of *Traquairaspis* and is succeeded higher in the formation by *B. crouchi*.

In the lower member of the Peel Sound Formation of Prince of Wales Island, a small heterostracan identified as *Pteraspis (Simopteraspis)* sp. occurs in association with traquairaspids, in strata dated as Late Silurian from associated invertebrates (Broad and Dineley 1973). Undescribed pteraspids, abundant in the upper member of the Peel Sound Formation, which is regarded as being of Gedinnian to Emsian age (Broad 1971, p. 99), are under study at the Geological Survey of Canada, Calgary, and at the University of Bristol.

Although pteraspids occur at several localities in the Mackenzie Mountains, their biostratigraphic use is limited because the relative stratigraphic positions of the ostracoderm horizons are uncertain. In the Delorme Formation, at GSC locality 69017, pteraspids occur stratigraphically above traquairaspids (Dineley 1968a); the enormous size of a pteraspid dorsal spine (NMC 21371) from this locality indicates that the pteraspids, which are represented by indeterminate fragments, were not of the small primitive type.

At GSC locality 69014, the small *C. alocostomata* with primitive features occurs with indeterminate fragments of larger and smaller pteraspids. In the primitive pattern of the lateral line system and in the form of the pre-oral field, *C. alocostomata* resembles *C. whitei*, the earliest known pteraspid from eastern Canada; the presence of the cyathaspids *Poraspis* cf. *P. polaris* and *Dinaspidella* sp. indet. supports correlation of the ostracoderm bed with the upper part of the Fraenkelryggen Formation (Red Bay Group) of Vestspitsbergen, which is believed to be equivalent in age to the lower part of the Dittonian of Britain (Ørvig 1969a).

*C. thymostomata* and *C. helostomata* occur only at GSC locality 81053. The similarity of the pre-oral area of these two species with that of *C. alocostomata* suggests a relationship, but the extreme length of the orbital plates indicates that they are more advanced than the latter species. Fragmentary, indeterminate pteraspid remains occur at GSC localities 81052 and 81057; associated ostracoderms at the latter locality suggest correlation with GSC locality 69014, but the comminuted and abraded state of the material suggests that it may have been reworked.

#### INCERTAE FAMILIAE

##### Genus ASEROTASPIS gen. nov.

*Diagnosis.* Armour largely of discrete, interlocking tesserae with superficial ornamentation of short (up to 5 mm), narrow (0.2 mm) flat-topped dentine ridges with a density of 2.5 per mm. Cephalothorax large, with broadly rounded anterior margin, and orbits placed antero-laterally; tesserae thick (0.6 mm) and spongy, with average length 6 mm and width 3 mm.

*Type species.* *A. canadensis*.

*Aserotaspis canadensis* sp. nov.

Plate 18; text-fig. 57

*Diagnosis.* As for genus, this being the only species.

*Holotype.* NMC 21460, fragment of anterior part of dorsal armour (Pl. 18; text-fig. 57).

*Other material.* NMC 21459, 21461–21462, 21493, isolated, associated, and poorly preserved tesserae.

*Locality.* GSC 69014.

*Description.* The dorsal armour consists of tesserae, which are separate in their deep and superficial layers; although varying in size and shape, they interlock to form a continuous cover (Pl. 18). Tesserae are commonly rectangular or lozenge-shaped, varying from 2 to 10 mm long and 2 to 4 mm wide (text-fig. 57). The external surface

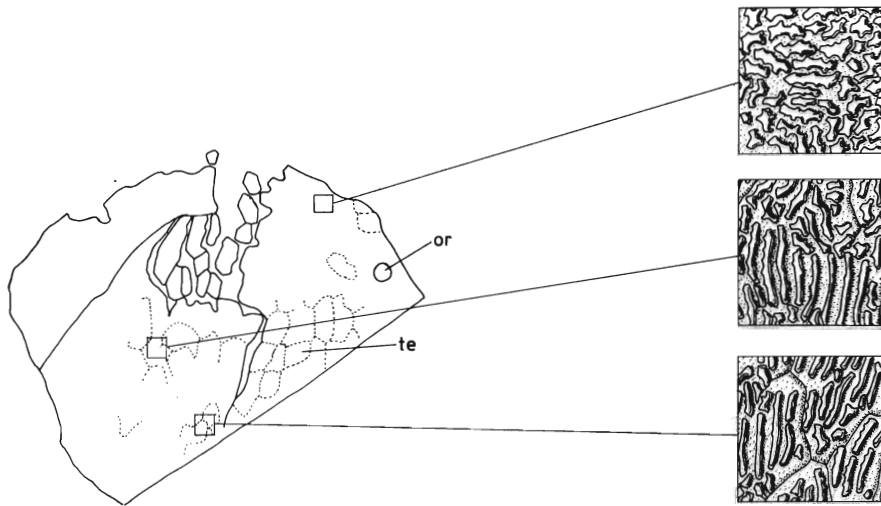

TEXT-FIG. 57. *Aserotaspis canadensis* gen. et sp. nov., variation in ornamentation of dorsal surface of cephalothorax (NMC 21460, holotype); plan view  $\times 0.75$ , detail  $\times 6$ . *or*, orbit; *te*, tesserae.

of each tessera bears an ornament of flat-topped dentine ridges with a width of approximately 0.2 mm; ridge density is in the order of 2.5 per mm, ridges being separated by grooves of equal width. In the central part of each tessera, ridges up to 5 mm long are arranged parallel to one another and to the long axis of the body; peripherally, ridges are divided into short length and arranged parallel to the margins of the tessera. Broken tesserae show the deeper layers to be of relatively thick (0.6 mm), spongy bone.

The holotype (NMC 21460; Pl. 18) reveals something of the shape of the animal; the dimensions of the cephalothorax are not determinable as it is incomplete. A continuous area of tesserae suggests a width of at least 75 mm and a length of over 60 mm. One orbit is preserved as an antero-lateral circular opening, 2.8 mm in diameter, close to the margin of the cephalothorax. Although the orbit is bordered

by a single row of short ridges, there does not appear to have been a separate orbital plate or tessera.

The postulated site of the orbit and shape of the shield are based on the assumption that the more posterior dentine ridges were largely longitudinal. If this was so, the anterior margin of the rostral area was broadly rounded. Toward the anterior end of the cephalothorax, dentine ridges are shorter (1–2 mm), broader (0.3–0.4 mm), and more closely spaced, and subdivision into tesserae is indistinct. The anterior margin is extremely fragmented and the left side of the cephalothorax is obscured because it is overlapped by a coarsely ornamented fragment of indeterminate origin (Pl. 18).

*Remarks.* Isolated tesserae of *A. canadensis* resemble tesserae which have been referred to *Tesseraspis* Wills, *Kallostrakon* Lankester, *Oniscolepis* Pander, and *Strosispherus* Pander. The last four genera are so poorly understood that they present problems in classification. *Tesseraspis* is known from associated tesserae, but *Kallostrakon*, *Strosispherus*, and *Oniscolepis* are known only from fragments and isolated tesserae. Berg (1940) established the family Tesseraspidae for *Tesseraspis*; Obruchev (1964) used a similar scheme, including *Strosispherus* (= *Oniscolepis*) in the Eriptychiidae and *Kallostrakon* in the Cardipeltidae. Stensiö (1964) included *Tesseraspis* and *Kallostrakon* as Heterostraci *incertae sedis*, but made no mention of *Oniscolepis* and *Strosispherus*.

Tarlo's (1964, 1965) revision of the Psammosteiformes included *Tesseraspis*, *Kallostrakon*, and *Oniscolepis* (= *Strosispherus*) in the family Tesseraspidae, which was defined as 'Carapace composed of tesserae differentiated into separate areas foreshadowing dorsal and ventral median and branchial plates of later forms. Tesserae of certain areas may be fused into separate plates' (Tarlo 1964, p. 2). Adhering to the view that heterostracan evolution proceeded only by the fusion of tesserae into plates, Tarlo (1964, 1965; Halstead 1973) has argued that the Tesseraspidae are close to the stock from which all other heterostracan lineages sprang.

Miles (1971) observed that such application of the 'lepidomorial theory' to the Heterostraci has led to incorrect interpretations of growth and to doubtful phylogenetic conclusions. There is no reason to suppose that evolution did not involve both fusion and subdivision of plates. Westoll (1967, p. 94) argued that, although the Tesseraspidae may be 'conservative "primitively" tesserate forms', they may equally well represent 'a rather advanced stage of reduction from better ossified ancestors'.

There are also doubts about Tarlo's (1964, 1965) species of *Tesseraspis*. Ørvig (1969a) recognized that, of Tarlo's six species, *T. talimaa* Tarlo was indistinguishable from *T. tessellata* Wills, *T. oervigi* was a psammosteid (*sensu stricto*), and *T. mutabilis* a traquairaspideid. There also appears to be little or no difference between *T. toombsi* Tarlo and *T. tessellata* Wills, and *T. denisoni* is probably a traquairaspideid.

---

EXPLANATION OF PLATE 18

*Aserotasps canadensis* gen. et sp. nov. Dorsal surface of cephalothorax (NMC 21460, holotype),  $\times 3.5$  (see text-fig. 57).



DINELEY and LOEFFLER, *Aserotaspis canadensis*



Of *Kallostrakon*, Tarlo (1965) recognized four species, *K. macanuffi*, *K. podura*, *K. alleni*, and *K. grindrodi*. Excepting only *K. podura* Lankester, the variation within each of the others appears to be at least as great as the interspecific variation. It is also difficult to ascertain to what extent *Kallostrakon* is tessellate; Tarlo's (1965) material included large plate fragments superficially subdivided into tesserae, and a number of 'tesserae' which may be fragments of the larger plates (Tarlo 1964, pl. 5; 1965, pl. 2).

Tarlo (1965) regarded *Strosispherus* as a synonym of *Oniscolepis* and referred to *O. dentata* all the six species recognized by Pander (1856). Karatajute-Talimaa (1970) has, however, referred the same species to *Strosispherus indentatus* Pander.

Thus it is preferable to refer *A. canadensis* to *Heterostraci incertae familiae* until the Tesserapididae are better known.

#### Genus NATLASPIS gen. nov.

*Derivation of name.* From Natla River, District of Mackenzie, and Greek *aspis* meaning shield.

*Diagnosis.* Heterostracan with dorsal shield formed of a single plate, which encloses orbital, branchial, and pineal apertures and extends anteriorly to cover rostrum. Dorsal ornamentation of broad, flat-topped ridges, arranged concentrically about orbits and pineal opening but longitudinally elsewhere. Ventral shield with concave anterior margin and ornamentation of broad, flat-topped ridges and tubercles, which are wider and more closely spaced near the longitudinal mid-line of shield than at lateral margins.

*Type species.* *Natlaspis planicosta*.

#### *Natlaspis planicosta* sp. nov.

Plate 19; text-figs. 58-60

*Diagnosis.* As for genus, this being the only species.

*Holotype.* NMC 19819, incomplete dorsal shield (Pl. 19, fig. 1; text-fig. 58).

*Paratypes.* NMC 19818, 19820 (Pl. 19, fig. 2), incomplete dorsal shields; NMC 19829 (Pl. 19, fig. 3), dorsal shield fragment, with branchial opening; NMC 19850, incomplete ventral shield (Pl. 19, fig. 5).

*Other material.* Twenty-four dorsal shield fragments: NMC 19821-19828, 19830-19843, 19848.

Sixteen ventral shield fragments: NMC 19843, 19847, 19851-19859, 21380-21384.

*Locality.* GSC 69017.

*Description.* The dorsal shield is a single plate which encloses the orbital, pineal, and branchial openings and extends forward to cover the rostrum. Although none of the dorsal shields is complete, the material indicates a range of sizes; the dorsal shield of NMC 19821 is estimated to have been 27 mm wide and at least 60 mm long; that of NMC 19822 is 60 mm long and 40 mm wide, and that of NMC 19818 is over 70 mm long and 30 mm wide.

The dorsal shield is widest immediately behind the branchial openings, which are elongated, laterally placed apertures lying in the anterior half of the shield. The rostrum is broadly rounded and its anterior margin can be seen to curve ventrally, forming a maxillary brim in NMC 19822. The dorso-lateral orbits have a diameter

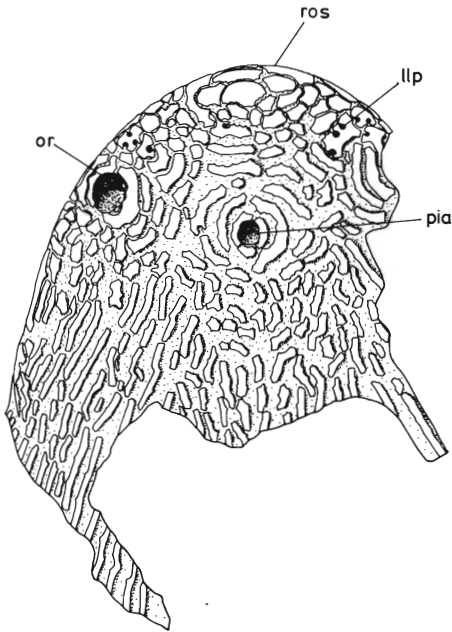

TEXT-FIG. 58. *Natlaspis planicosta* gen. et sp. nov., incomplete dorsal shield showing details of ornamentation and position of lateral line pores (NMC 19819, holotype);  $\times 1.875$ . *llp*, lateral line pores; *or*, orbit; *pia*, pineal opening; *ros*, rostrum.

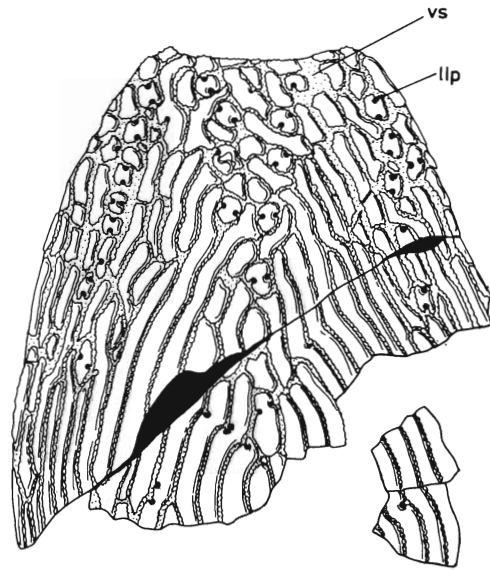

TEXT-FIG. 59. *Natlaspis planicosta* gen. et sp. nov., incomplete ventral shield (*vs*) showing details of ornamentation and position of lateral line pore (*llp*) (NMC 19850, paratype);  $\times 1.875$ .

of 2.5–3.0 mm. The pineal aperture opens on to the surface of the shield close behind the inter-orbital line (text-fig. 58). An underturned ventro-lateral lamina, several millimetres wide, extends along the lateral margins of the shield from a point anterior to the orbits. The dorsal shield is only slightly convex.

Dorsal ornamentation is of flat-topped ridges with finely serrated margins, separated by grooves with pitted surfaces. On the posterior half of the dorsal shield, ridges are relatively narrow (0.4 mm) and grooves wide (0.8 mm). The ridges are commonly subdivided into short lengths (1.5–3.0 mm), but may be up to 20 mm long (Pl. 19, fig. 2). On the anterior half of the shield, in front of the branchial openings, narrow (0.4 mm) ridges and wide (0.8 mm) grooves are arranged concentrically about the pineal foramen. Ridges are also concentrically arranged about the orbits (text-fig. 60), but the grooves are narrow (0.1–0.3 mm) and the ridges wide (0.8–1.5 mm). Broad ridges and narrow grooves, similar to those of the orbital region, continue on the lateral margins of the shield, between the orbits and the branchial openings (Pl. 19, fig. 3; text-fig. 60).

Rostral ornamentation is of several large tubercles anteriorly, grading posteriorly into finer ridges and tubercles (Pl. 19, fig. 1). Although rostral, pineal, and orbital ornamentation is distinctive, there is a complete gradation between them, with no indication of separate plates or epitega.

In only one specimen, NMC 19849 (Pl. 19, fig. 4), are dorsal and ventral shields associated, but the dorsal shield is represented only by small fragments. The anterior margin of the ventral shield is concave, the antero-lateral corners rounded; the shield is widest midway along its length and tapers only slightly to the posterior end (Pl. 19, fig. 4). As with the dorsal shields, there appears to be a range of sizes. NMC 19849 is at least 55 mm long and 47 mm wide; NMC 19852 is 35 mm long and 25 mm wide. Although most of the ventral shields have been flattened, NMC 19850 suggests that the ventral shield was vaulted, at least posteriorly.

Ornamentation of the ventral shield, like that of the dorsal, comprises flat-topped ridges separated by pitted grooves. Over most of the ventral shield, ridges are longitudinal with slight anterior convergence (Pl. 19, fig. 4); anteriorly they are subdivided

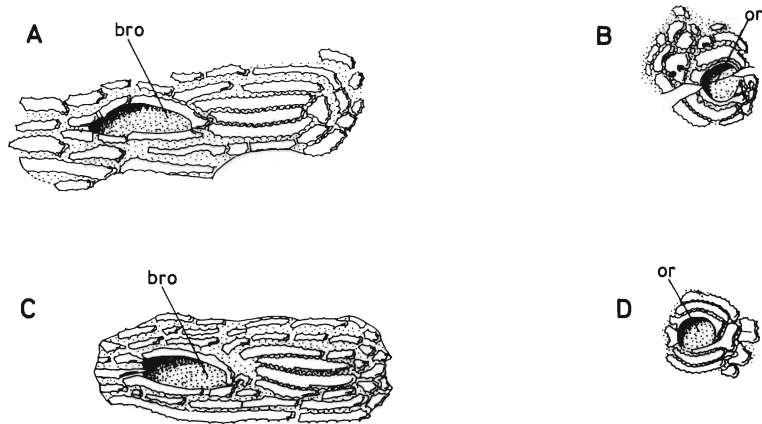

TEXT-FIG. 60. *Natlaspis planicosta* gen. et sp. nov., plate fragments with orbital (*or*) or branchial (*bro*) openings;  $\times 1.875$ . A, branchial opening (NMC 19827); B, orbit (NMC 19831); C, branchial opening (NMC 19829, paratype); D, orbit (NMC 19832).

into short lengths and have a fan-like or irregular arrangement. Near the longitudinal mid-line of the ventral shield, ridges are broad (1.0–1.5 mm) and grooves narrow (0.2–0.4 mm); toward the lateral margins, grooves become wider (up to 0.6 mm) and ridges narrower (0.3–0.4 mm) (Pl. 19, figs. 4, 5). An unornamented brim, approximately 1 mm wide, extends along the lateral margin of the ventral shield; it can only be seen in specimens where the matrix has been removed (NMC 21384, 19857).

*Remarks.* This species resembles *?Traquairaspis adunata* and *?T. mackenziensis* in having a single dorsal plate, which encloses the orbital, branchial, and pineal openings.

#### EXPLANATION OF PLATE 19

Figs. 1–5. *Natlaspis planicosta* gen. et sp. nov. 1, incomplete dorsal shield (NMC 19819, holotype),  $\times 2$  (see text-fig. 58). 2, incomplete dorsal shield (NMC 19820, paratype),  $\times 2$ . 3, shield fragment with branchial opening (NMC 19829, paratype),  $\times 2$  (see text-fig. 60c). 4, incomplete ventral shield, with fragments of dorsal shield at left postero-lateral margin (NMC 19849),  $\times 2$ . 5, incomplete ventral shield (NMC 19850, paratype),  $\times 2$  (see text-fig. 59).

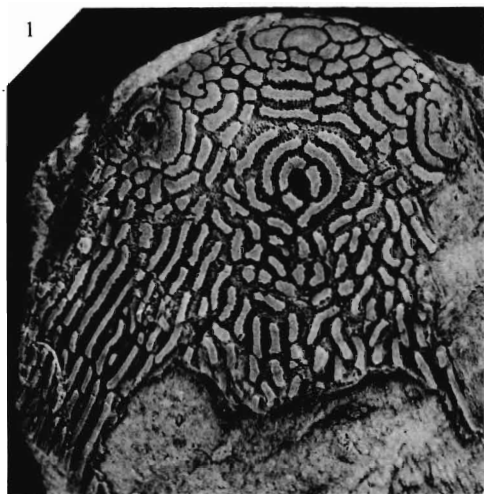

DINELEY and LOEFFLER, *Nataspis planicosta*

The three species all have a distinct pineal opening rather than a macula, another feature which is otherwise unknown in the Heterostraci.

*N. planicosta* does not have an ornamentation of cyclomoriform units, but there are striking similarities with the Traquairaspididae in the distribution of dentine ridges. As in the two traquairaspidids mentioned above, the dorsal ornamentation of *N. planicosta* is coarsest on the rostrum, around the orbits, and in front of the branchial openings. The ventral ornamentation of *N. planicosta*, ?*T. mackenziensis*, and ?*T. lemniscata* is of laterally serrated ridges which broaden and flatten toward the longitudinal mid-line of the ventral shield. Although isolated orbital fragments of *N. planicosta* closely resemble orbital plates of *Corvaspis*, this is also true of isolated orbital pieces of ?*T. mackenziensis*. Material from the Gossage Formation of northern Yukon was ascribed to *Corvaspis* (Dineley 1965), but the ornamentation is more like that of *N. planicosta*.

*N. planicosta* is similar to some members of the Traquairaspididae and might best be accommodated in a new subfamily. For the moment, however, it is referred to Heterostraci *incertae familiae*.

#### HETEROSTRACI indet., Type 1

Plate 20, figs. 1, 2, 4; text-figs. 61, 62

*Material.* NMC 21385-21386, 21388-21394, nine ?dorsal plate fragments; NMC 21387, 21438-21446, ten ?ventral plate fragments.

*Locality.* GSC 69017.

*Description.* Plate fragments are of two distinct types. Those which have been ascribed to the dorsal surface of the headshield have an ornamentation of relatively narrow (0.5-1.0 mm), flat-topped, laterally serrated ridges (text-fig. 61). These vary in length from 1.5 to 25.0 mm and have a largely longitudinal arrangement with

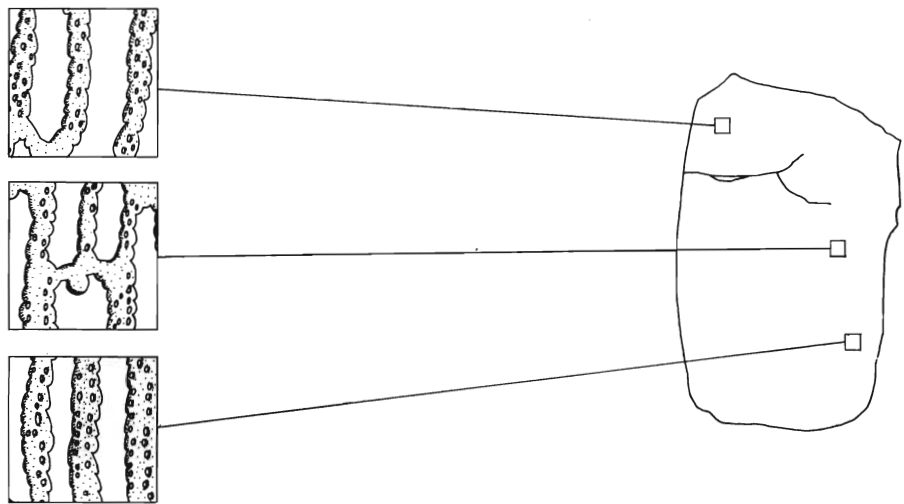

TEXT-FIG. 61. Heterostraci indet., Type 1, variation in ornamentation across ?dorsal shield (NMC 21386); plan view  $\times 0.75$ , detail  $\times 6$ .

a tendency to converge anteriorly and posteriorly. The flat-topped ridges are separated from one another by broad grooves (0.5–1.0 mm wide), on the floors of which are small, boss-shaped tubercles approximately 0.1 mm in diameter (text-fig. 61).

Natural margins are preserved in a few specimens. The dorsal plate is estimated to have been some 60 mm long and 40 mm wide; it appears, from NMC 21392, to have been moderately vaulted and to have had a lateral lamina directed ventrolaterally.

On both the postero-lateral part of the ventral plate and on the dorsal plate, flat-topped, laterally serrated ridges are separated from one another by grooves containing low, boss-shaped tubercles (text-fig. 62). This type of ornamentation grades

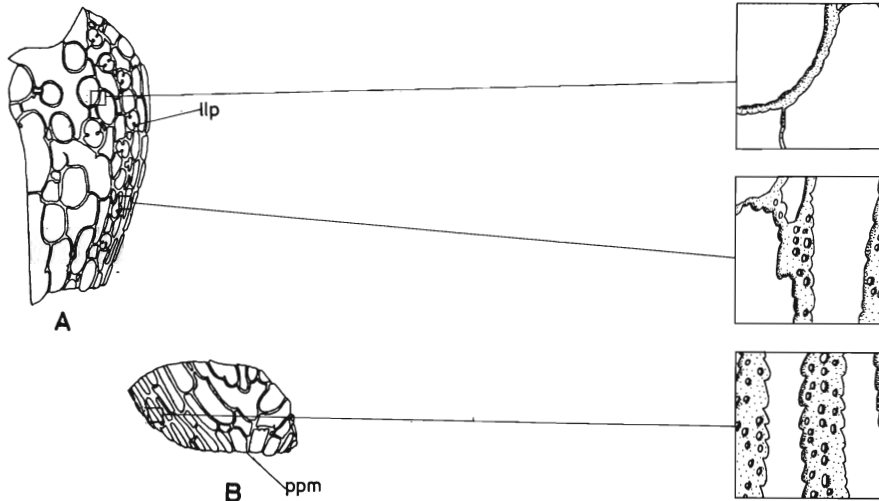

TEXT-FIG. 62. Heterostraci indet., Type 1, variation in ornamentation on ventral plates; plan view  $\times 0.75$ , detail  $\times 6$ . A, NMC 21442; B, NMC 21444. llp, lateral line pore; ppm, posterior margin.

medially into one of large (up to 5 mm in diameter), oval, circular, and irregularly shaped tubercles, which are separated from one another by narrow (0.2 mm) grooves. NMC 21444 (Pl. 20, fig. 4; text-fig. 62B) appears to be part of the posterior part of a ventral plate; the hind margin is transverse and the postero-lateral corners are rounded. NMC 21442 (Pl. 20, fig. 2; text-fig. 62A) is one of the more complete specimens; its lateral margin is convex, with a narrow (2 mm wide) brim ornamented by tiny (0.2 mm diameter) pustules.

Lateral line pores are conspicuous on the dorsal and ventral plates. On dorsal plates, they are commonly associated with broad ridges, the margins of which they notch. On ventral plates, the lateral line pores notch diametrically opposite sides of large circular tubercles (text-fig. 62A); the alignment of pores in NMC 21442 indicates the presence of a lateral ventral sensory canal.

*Remarks.* The ornamentation of this form resembles that of *N. planicosta* which, however, lacks the interstitial boss-like tubercles, and also that of some traquiraspidids (p. 43). Medial ventral ornamentation of large, oval, circular, and

concave-sided tubercles occurs in ?*T. pustulata* and ?*T. lemniscata*, but in these two species lateral ornamentation is typically traquairaspigid.

### HETEROSTRACI indet., Type 2

Text-fig. 63

*Material.* NMC 19946, incomplete ?dorsal shield; NMC 19947, incomplete ?ventral shield; NMC 19948-19950, shield fragments.

*Locality.* GSC 69017.

*Description.* The broken and incomplete ?dorsal shield is estimated to have been at least 57 mm long and 40 mm wide; the lateral margins are convex and the anterior margin appears to have been broadly rounded. The anterior end of the shield is slightly underturned and is presumed to have covered the rostrum; orbital or branchial openings or notches are not distinguishable.

Dorsal ornamentation is of short (up to 0.6 mm long), closely spaced (eight

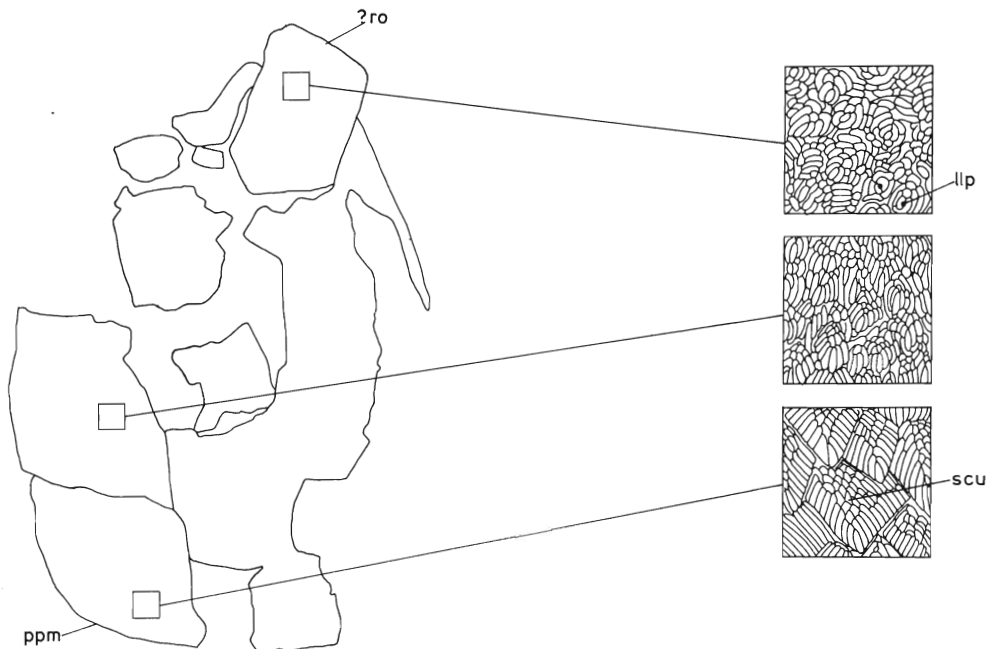

TEXT-FIG. 63. Heterostraci indet., Type 2, variation in ornamentation of ?dorsal shield (NMC 19946); plan view  $\times 1.25$ , detail  $\times 6$ . *llp*, lateral line pore; *ppm*, posterior margin; *ro*, ?rostrum; *scu*, scale unit.

#### EXPLANATION OF PLATE 20

Figs. 1-4. Heterostraci indet. 1, Type 1, ?dorsal shield fragment (NMC 21386),  $\times 2$  (see text-fig. 61). 2, Type 1, ?ventral shield fragment (NMC 21442),  $\times 2$  (see text-fig. 62A). 3, Type 3, shield fragment (NMC 21489a),  $\times 2$  (see text-fig. 64). 4, Type 1, ?ventral shield fragment (NMC 21444),  $\times 2$  (see text-fig. 62B).

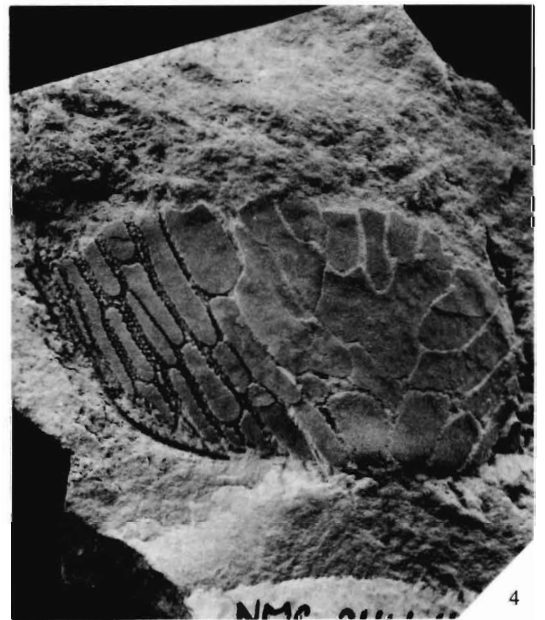
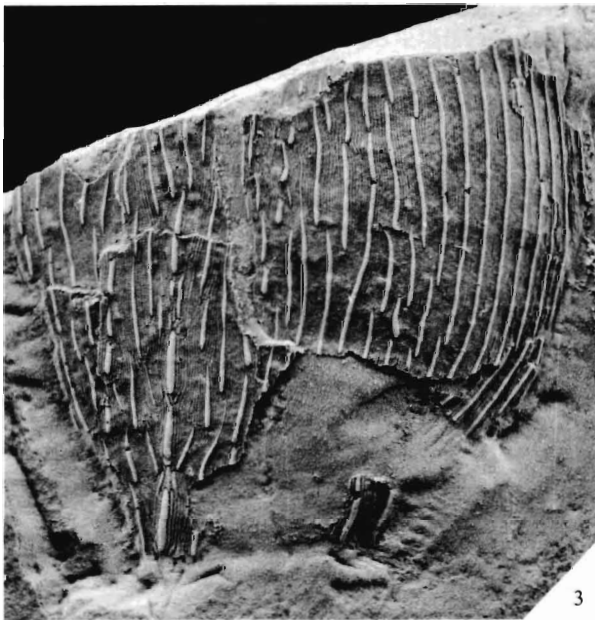

DINELEY and LOEFFLER, Heterostraci indet.



per mm) dentine ridges of low relief grouped into small units, 1 to 2 mm in diameter (text-fig. 63). On the anterior part of the ?dorsal shield, units are irregularly cyclomoriform and commonly interrupted by lateral line pores. Approximately midway along the length of the shield, ridges are still irregularly cyclomoriform, but tend to a markedly longitudinal arrangement. Toward the posterior end of the shield, the cyclomoriform character of the ridges is gradually lost and they are arranged in rhomboidal, scale-like units approximately 2 mm in diameter and of imbricated appearance (text-fig. 63). These subdivisions are entirely superficial; they do not extend to the cancellous or basal layers of the shield.

The ?ventral shield is approximately 50 mm long and 48 mm wide; its lateral margins are convex and its antero-lateral corners deeply notched. Superficial subdivision of the dentine ridges into rhomboidal, scale-like areas is present on all parts of the ventral shield which are preserved. Along the anterior and antero-lateral margins of the ventral shield, a narrow (0.8 mm) band of eight to ten ridges is arranged parallel to the edge of the shield.

*Remarks.* Superficial subdivision of the shield into scale-like areas is known in *Corvaspis*, *Tolypelepis*, and *Ptomaspis*, but in none of these genera is ornamentation so intricate or ridges so narrow as in this material. In *Tolypelepis* and *Ptomaspis* there are distinct epitegal subdivisions and in *Corvaspis* the shield completely encloses the orbits; although poorly preserved, this material exhibits none of these features.

#### HETEROSTRACI indet., Type 3

Plate 20, fig. 3; text-fig. 64

*Material.* NMC 21489a and b, large shield fragment and counterpart; NMC 21490-21492, three small shield fragments.

*Locality.* GSC 58497.

*Description.* The larger fragment (NMC 21489; Pl. 20, fig. 3), which is 30 mm long and 42 mm wide, appears to be the posterior part of either a dorsal or a ventral shield. The ornamentation is of laterally serrated dentine ridges of two sizes: high, relatively wide (0.4 mm) ridges with gently rounded crests are separated by low, narrow (0.1-0.2 mm) flat-topped ridges with a density of five to six per mm (text-fig. 64). Medially, up to twelve narrow ridges separate adjacent wide ridges, but laterally the close spacing of wide ridges permits intercalation of only five or six narrow ridges.

Toward the side of the shield, ridges of both types are long and parallel, rarely being interrupted by lateral line pores (Pl. 20, fig. 3). Near the longitudinal mid-line of the shield, the wider ridges are subdivided into short (1.5-8.0 mm) lengths, which are narrower towards the anterior end; around these, interstitial ridges have a cyclomoriform arrangement.

Lateral line pores are associated with many of the elevated ridges; they commonly notch the anterior and posterior margin of each lachrymiform ridge. The alignment of the lateral line pores suggests the presence of a median pair of longitudinal sensory canals. Ornamentation has a generally longitudinal arrangement, with a tendency to posterior convergence (Pl. 20, fig. 3). Toward the posterior end of the shield, the alignment of several large, cyclomoriform units forms a slightly elevated median crest (Pl. 20, fig. 3).

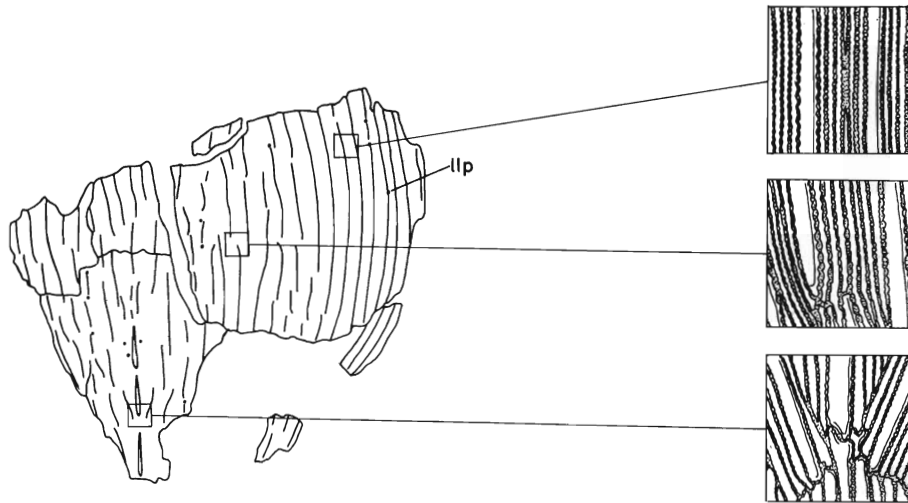

TEXT-FIG. 64. Heterostraci indet., Type 3, variation in ornamentation on indeterminate shield fragment (NMC 21489); plan view  $\times 1.25$ , detail  $\times 6$ . *llp*, lateral line pore.

*Remarks.* An ornament of long, coarse ridges separated by finer ridges is a feature held to be characteristic of *Cyathaspis*, but is also known in *Archegonaspis integra* (Kunth), certain traquairaspidids (this work), and in indeterminate Heterostraci from south-eastern Yukon (Denison 1963). In *Cyathaspis*, *Archegonaspis*, and Heterostraci indet., Type C (Denison 1963), the lateral margins of the dentine ridges are smooth but, in the Traquairaspididae, they have variously developed lateral serrations. Ornamentation of these specimens most closely resembles that on the lateral margins of the dorsal shield of ?*Traquairaspis mackenziensis*. Although cyclomoriform ornamentation is present on the posterior of the shield, the present material cannot be referred to the Traquairaspididae.

#### HETEROSTRACI indet., Type 4

Plate 21, figs. 1, 2

*Material.* NMC 21450, incomplete ?dorsal plate; NMC 21449, incomplete ?ventral plate.

*Locality.* GSC 69017.

*Description.* Both fragments are similarly ornamented, but differ in shape. NMC 21450 (Pl. 21, fig. 1) is part of what appears to be a symmetrical median plate at least 60 mm long and 35 mm wide. It has a longitudinal, median crest, which is highest (7 mm) at the centre of the plate; it slopes steeply toward the ?posterior end of the plate and gently toward the other. In the former direction, the crest is not continuous, being represented by a series of elevated groups of ridges.

Ornamentation in NMC 21450 is variable but typically consists of short (up to 3 mm), narrow (0.1–0.4 mm), round-crested ridges of non-uniform height, with more or less prominent lateral branches (Pl. 21, fig. 1). The median crest, which is ornamented with gnarled and overgrown (?secondary) ridges forms the central element

of a large cyclomoriform unit 20 mm wide and over 30 mm long. Within this unit, ornament typically consists of broad, elevated ridges, with rare lateral processes, and low interstitial ridges; ridges of both types converge around the median crest. Outside the cyclomoriform unit, ridges are more uniform in height; locally they have lateral branches and may be lachrymiform in shape. These ridges have a generally longitudinal arrangement.

A smaller (11 × 9 mm), symmetrical, rhomboidal plate associated with NMC 21450 (Pl. 21, fig. 1) has ornamentation of short ridges with long lateral projections, which resemble those locally developed on the larger plate. It is assumed to be a minor plate or scale of the same individual.

NMC 21449 (Pl. 21, fig. 2) is less than half of a large median plate, which was at least 80 mm long. The lateral margin is convex and the posterior margin irregularly indented. The ornamentation resembles that of NMC 21450, in comprising short (1–8 mm), narrow (0.1–0.4 mm), round-crested ridges with variously developed lateral processes. On some parts of the plate, broader, higher ridges are separated by narrow ridges; in others, all ridges are of similar size. As in NMC 21450, tubercles with long, lateral processes are locally developed. Although ornamentation is generally longitudinal, there are irregular areas of oblique and transverse ridges (Pl. 21, fig. 2).

*Remarks.* In shape, NMC 21450 resembles the dorsal median plate of *Weigeltaspis*, which is long and narrow with a prominent median crest. The ornamentation of *Weigeltaspis*, however, differs from that of these specimens; the superficial tubercles of *Weigeltaspis* are shaped like oak leaves (Tarlo 1965), have a complex system of crests (Ørvig 1961), and lack cyclomoriform arrangement.

#### HETEROSTRACI indet., Type 5

Plate 21, fig. 4

*Material.* NMC 21533, orbital plate or shield fragment (Pl. 23, fig. 5).

*Locality.* GSC 58497.

*Description.* NMC 21533 (Pl. 21, fig. 4) is a fragment approximately 10 mm in diameter, with a central circular orbit 3 mm across. Ridges adjacent to the orbit are similar on both halves of the plate; ornamentation on either side of the orbit itself differs. On one half of the plate, curved and semicircular ridges up to 0.4 mm wide are arranged parallel to the margin of the orbit. Each ridge is flat-topped and has short lateral projections; narrow (less than 0.3 mm wide) spaces between ridges are commonly occupied by minute, stellate tubercles. On the other half of the plate, the ornament is of flat-topped polygonal tubercles up to 2 mm in diameter; interstitial

---

#### EXPLANATION OF PLATE 21

Figs. 1–4. Heterostraci indet. 1, Type 4, incomplete ?dorsal shield (NMC 21450), × 2. 2, Type 4, incomplete ?ventral shield (NMC 21449), × 2. 3, Type 6, indeterminate plate fragment (NMC 21513), × 2. 4, Type 5, orbital fragment (NMC 21533), × 3.

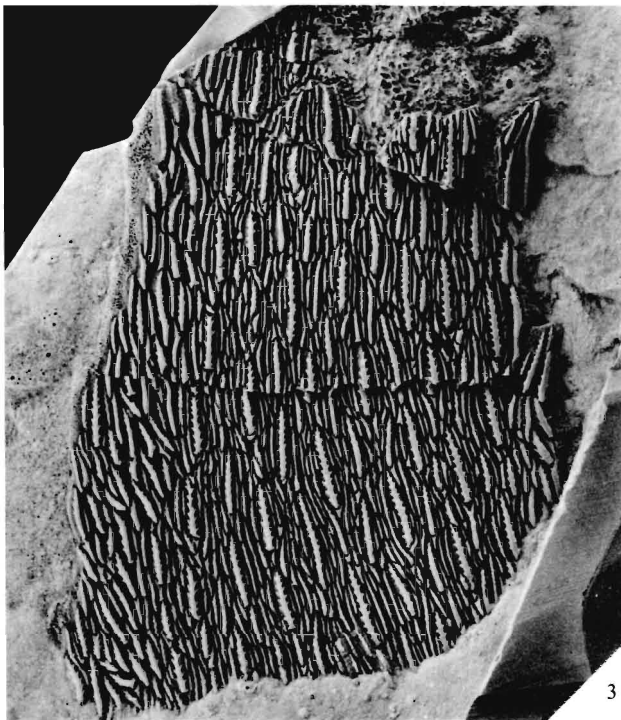
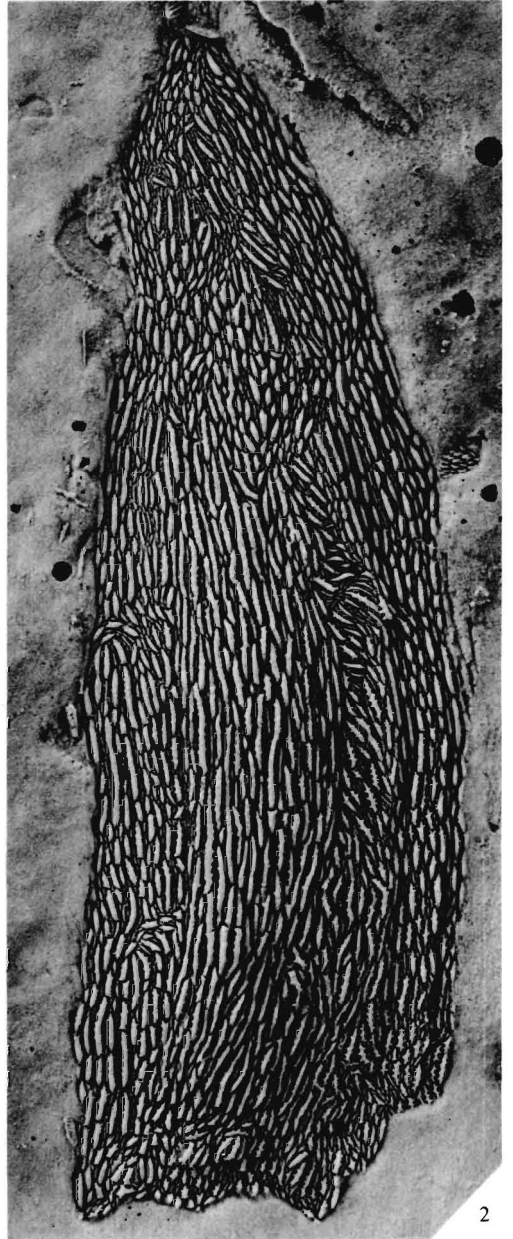
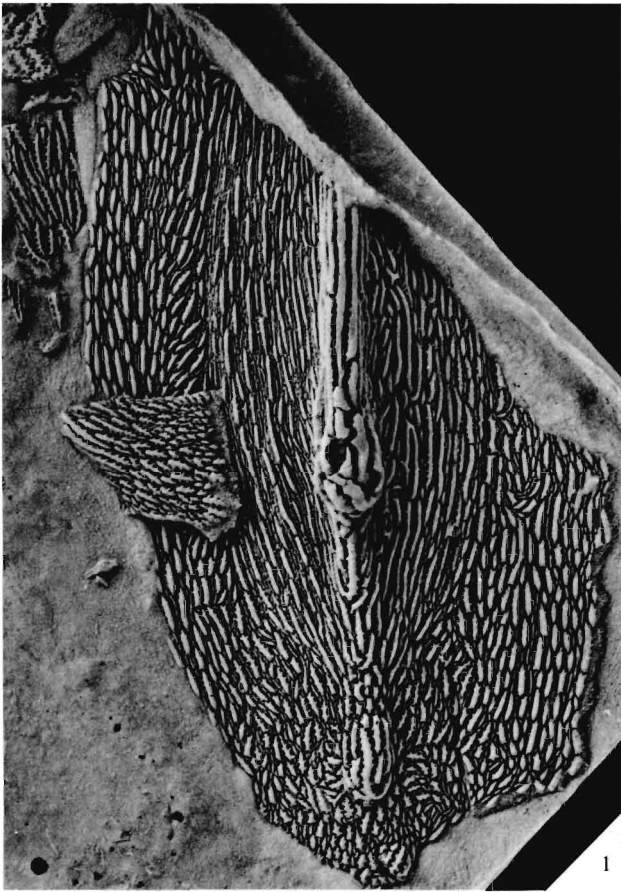

DINELEY and LOEFFLER, *Heterostraci* indet.

grooves, which are approximately 0.2 mm wide, contain tiny polygonal and stellate tubercles.

The margins of the plate or plate fragment are irregular and the plate arched to a depth of approximately 2 mm.

*Remarks.* This specimen closely resembles a plate attributed to *Corvaspis* aff. *C. kingi* from the Gossage Formation of the Snake River area (Dineley 1965, pp. 94–95, fig. 4). Similarly ornamented, completely enclosed, orbits are also known in the Traquairaspididae (p. 22 above).

#### HETEROSTRACI indet., Type 6

Plate 21, fig. 3

*Material.* NMC 21513–21518, six fragments.

*Localities.* GSC 69014, 81053.

*Description.* None of these incomplete plate fragments has any indication of scale-like units; the deep layers of the exoskeleton are continuous and up to 2 mm thick. Of the three plate fragments which have a marked convexity (NMC 21414, 21516, and 21517), two have well-developed median, longitudinal crests.

Slender, barbed ridges up to 6 mm long, with lateral barbs extending from the central axis at a low angle and constant direction (Pl. 21, fig. 3) ornament each of these fragments. On all but the margins of plates, ridges are of two types: 1. Elevated, barbed ridges, arranged parallel to the long axis of the plate, with a distance of approximately 2.0–2.5 mm between adjacent ridges. These ridges are commonly abraded, and are approximately 0.5 mm wide. 2. Lower, narrower (0.2 mm wide) barbed ridges with a cyclomoriform arrangement about the elevated tubercles and an interval of 0.4–0.5 mm between adjacent ridges.

At the lateral margins of the plates, wide (0.5 mm), barbed ridges are arranged, with varying orientations, adjacent to an unornamented border up to 3 mm wide. On the raised, median crest, wide ridges predominate; in one specimen (NMC 21516) they are locally broad (1.0 mm), irregular, and bulbous.

*Remarks.* The barbed dentine ridges are similar to those of *Lepidaspis serrata* (see p. 175), but their differentiation into coarse and fine types, and their arrangement in cyclomoriform units, is typical of the Traquairaspididae.

#### ORDER THELODONTIDA KIAER, 1932

##### Genus SIGURDIA Heintz, 1970

*Synonymy.* 1970 *Sigurdia* gen. nov.; Heintz.

*Diagnosis* (modified after Heintz 1970). Broad, dorso-ventrally compressed thelodont with trapeze-shaped cephalothorax and small pectoral flaps. Post-pectoral body broad, with enlarged denticles or spines on lateral margins.

*Type species.* *Sigurdia lata* Heintz.

*Sigurdia heintzae* sp. nov.

Plate 22

*Derivation of name.* *heintzae* after Natascha Heintz, who established the genus *Sigurdia*.

*Diagnosis.* Cephalothoracic region long and narrow, with posteriorly directed pectoral flaps. Post-pectoral body relatively narrow, with enlarged lateral denticles but lacking spines. Denticles lanceolate, with slightly concave dorsal surface.

*Holotype.* NMC 13751, incomplete, articulated specimen (Pl. 22).

*Paratypes.* NMC 13752–13755, incomplete, articulated specimens.

*Other material.* NMC 13756–13760, incomplete, articulated specimens.

*Locality.* GSC 69014.

*Description.* Of the ten (incomplete) specimens, five (NMC 13751–13755) give an indication of the over-all body shape. Some of the less complete specimens, however, are considerably larger than those upon which the description is based. Only the holotype (NMC 13751) is sufficiently well preserved to permit measurement of the parameters used by Heintz (1970):

(A) Anterior breadth, 12 mm; (B) Length from antero-external angle to lateral corner of pectoral flap, 30 mm; (C) Width of body with pectoral flaps, 30 mm; (D) Width of post-pectoral body immediately behind pectoral flaps, 25 mm; (E) Length of cephalothorax, 25 mm.

The specimens are all dorso-ventrally compressed, but details of internal structures, mouth and orbits are not visible. The cephalothoracic region is broad posteriorly, narrowing gradually to the anterior end, where the margin is missing. The pectoral flaps are small, with rounded tips, which appear to have been directed posteriorly. The body narrows immediately behind the pectoral flaps, its lateral margins commonly having larger denticles than the rest of the body. In NMC 13752 the post-pectoral body widens approximately 15 mm behind the pectoral flaps; preservation is too poor to reveal whether this is a caudal fin. The lateral margins of the post-pectoral region are commonly plicated, but there are no lateral spines.

Little of the shape of the body can be deduced from the larger, less complete specimens (NMC 13757–13760). NMC 13757 consists of a narrow band of articulated denticles (55 mm long  $\times$  5 mm wide); the natural margin is almost straight, but has minor plications. In NMC 13758, an area (100  $\times$  50 mm) of articulated denticles, one of the natural margins is linear, the other is convex with minor plications. NMC 13759 has a gently convex natural margin and is about 66 mm long; this specimen reveals traces of canals, which may be part of a lateral line sensory system. NMC 13760, having no natural margins, gives no indication of body shape.

Despite great variation in the size of articulated specimens, the denticles all appear to be of similar type; those near the lateral margins of the post-pectoral body are commonly largest and best preserved. Individual denticles are typically lanceolate, with slightly concave dorsal surfaces; *in situ* they have an imbricated arrangement. On the internal surface of the squamation, articulated denticles resemble close-packed rings, the base of each denticle being perforated by a broad, circular opening to the pulp cavity.

*Remarks.* The dermal armour indicates the thelodont affinities of these fossils. Overall body shape of the smaller, more complete specimens (NMC 13751–13755) is like that of *Sigurdia lata* Heintz, which differs markedly from other articulated thelodonts. The following differences suggest that these specimens, although probably co-generic with *S. lata*, are not co-specific. The cephalothoracic region of *S. heintzae* sp. nov. is longer and narrower than that of *S. lata*, the pectoral flaps are narrower and more posteriorly directed, and lateral spines are absent. *S. lata* is based on a unique, incomplete specimen with poorly preserved scales. The material from the District of Mackenzie indicates that Heintz was correct in including *Sigurdia* with the Thelodonti. Although the denticles are too poorly preserved to be sectioned, the wide openings to the pulp cavity suggest that they are of the 'Thelodus-type' (Gross 1967).

#### THELODONTIDA indet.

Text-figs. 65, 66

*Material.* Twenty-one isolated denticles, obtained from residues produced by solution of a small sample of limestone in 15% acetic acid.

*Locality.* GSC 81057.

*Description.* The denticles can be divided into five different types, of which Type 1 is the most common.

*Type 1.* Oval denticles in which the base and crown are of similar size. The upper surface has a median longitudinal depression; the lower surface has a broad, oval opening to the pulp cavity (text-fig. 65C, E).

*Type 2.* Denticles with a single broad median concavity (as in Type 1) or several narrow, longitudinal grooves. The basal part of the scale is relatively small, the crown being prolonged posteriorly (text-figs. 65A, B, 66D, E).

*Type 3.* Stud-like denticles with broadly indented margins and neck. The base of the denticle is more or less thickened; the circular opening to the pulp cavity is smaller in denticles with thicker bases (text-fig. 66A–C).

*Type 4.* Small denticles with base and crown of similar size. The external surface has a median, triangular portion and narrow lateral flanges; the opening to the pulp cavity is large and oval (text-fig. 65D).

*Type 5.* Elongated denticles with broad pulp cavity and well-developed lateral alae.

Too few good specimens were available to place these denticles within Gross's (1967) system of classification. They are therefore referred to Thelodontida indet. Denticles of Type 1 resemble those of articulated specimens of *S. heintzae* sp. nov. Skeletal elements of ostracoderms which occur in association with *S. heintzae* at GSC locality 69014 are also found in the residues from GSC 81057.

---

#### EXPLANATION OF PLATE 22

*Sigurdia heintzae* sp. nov. Articulated specimen (NMC 13751, holotype), ×4 (approx.).



DINELEY and LOEFFLER, *Sigurdia heintzae*



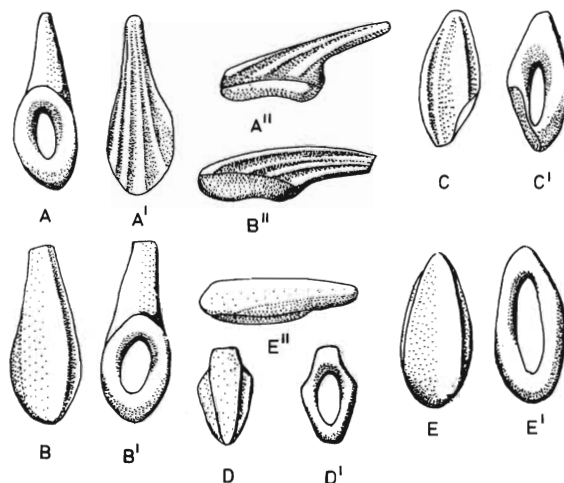

TEXT-FIG. 65. *Thelodontida* indet., isolated denticles;  $\times 25$ . A, Type 2; B, Type 2; C, Type 1; D, Type 4; E, Type 1.

#### GENERAL COMMENTS ON THE THELODONTIDA

##### *Classification and interrelationships of the Thelodontida*

Westoll (1945) held that the Coelolepida (= Thelodontida) included fishes of at least two different groups. He regarded *Turinia pagei* as related to the Cephalaspido-morpha, and *Thelodus planus*, *T. scotticus*, *T. taiti* (= *Logania* Gross), and *Lanarkia* as related to the Pteraspido-morpha; a third group, containing *Phlebolepis*, he regarded as resembling the Anaspida.

Stensiö (1964) subdivided the class Thelodonti into two superorders, the Thelodontida and the Phlebolepida, on the basis of gross morphology and denticle micro-structure. He considered that the Phlebolepida, containing only *Phlebolepis*, more closely resemble the Osteostraci. The Thelodontida, containing *Thelodus* and *Lanarkia*, were thought to resemble more closely the Heterostraci. *Turinia* was removed from the rest of the thelodonts and placed in the Pteraspido-morpha because of supposed similarities in branchial structure.

Detailed morphological and histological studies of individual denticles led Gross (1967) to a much-needed revision of thelodont classification; this established the genera *Logania*, *Gonioporus*, and *Kataporus*, and reinstated *Turinia*. Gross recognized two histologically different types of denticle. The *Thelodus*-type, which is present in *Thelodus*, *Turinia*, and *Lanarkia*, is characterized by dentine tubules which arise from one to three large pulp cavities and are seldom branched. The 'Kataporus-type', which is present in *Kataporus*, *Gonioporus*, *Logania*, and *Phlebolepis*, has numerous, posteriorly situated pulp cavities, which give rise to branching bundles of tubules in the mesodentine crown.

From his work on articulated specimens of *P. elegans*, Ritchie (1967) concluded

that the thelodonts were remarkably uniform in gross morphology, but that their relationship with other agnathans remained uncertain. He felt that his discovery of a condensed row of branchial apertures in *Logania* and *Lanarkia* did not necessarily substantiate Westoll's (1945) hypothesis that thelodonts might be akin to the anaspids, but that it did bring into doubt any suggestion of a relationship between the Thelodontida and the Heterostraci. These doubts were echoed by Heintz (1970).

The gross morphology of *Sigurdia* is rather different from that of the other articulated thelodonts; the post-pectoral body is long and broad and may have spines, distinct pectoral flaps being present anteriorly. Unfortunately, the scales of *Sigurdia* are too poorly preserved for sectioning, and it is not possible to place the genus within Gross's (1967) classification.

In the classification used here, the Heterostraci and Thelodontida are separated at ordinal level, but are questionably united in the subclass Diplorhina (see p. 15). From the morphology of the genus *Sigurdia*, it appears that the Thelodontida may be further subdivided once histological studies have been carried out on *Sigurdia*.

#### *Biostratigraphic significance of the Thelodontida*

The Thelodontida make their first undisputed appearance in the Late Llandoveryan, and their last in the Emsian. Articulated specimens are known for only nine species, the majority of 'species' being based on isolated denticles. Their particular value lies

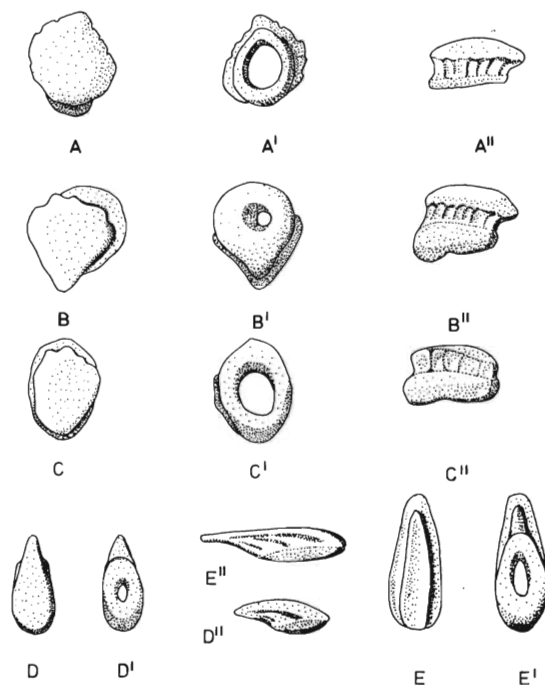

TEXT-FIG. 66. Thelodontida indet., isolated denticles;  
 ×25. A, Type 3; B, Type 3; C, Type 3; D, Type 2;  
 E, Type 2.

in the small size of the denticles, which can be retrieved from core or other small samples and from a variety of lithologies. The major disadvantage is that histological study is necessary to identify the denticles because, although crown ornament is the primary basis for identification, confusing similarity exists between denticles from the same region of the body of different forms.

Gross's (1967) zonation of the Silurian and Devonian by means of thelodonts has been elaborated by Turner (1973). She recognized four scale-assemblages in the Downtonian and Dittonian of the Anglo-Welsh borders and regarded the incoming of *Turinia pagei* at the beginning of the Dittonian (*sensu* Allen and Tarlo 1963) as marking a principal faunal change, which can be correlated with the Beyrichienkalk erratics and the Polish, Lithuanian, and Vestspitsbergen sequences. Thelodonts have been used in the Baltic region (Karatajute-Talimaa 1962, 1964, 1968a, 1970; Mark-Kurik 1969; Mark-Kurik and Noppel 1970) for sub-surface stratigraphic and regional correlation.

During the present study, isolated thelodont denticles were found only at GSC locality 81057, the whereabouts of which is uncertain (p. 11).

#### ORDER OSTEOSTRACI LANKESTER, 1886

##### Family CEPHALASPIDIDAE Huxley, 1861

*Diagnosis* (after Denison 1951). Cornua and pectoral sinuses distinct; pectoral fins developed but lack thickened lateral rim. Shield broad, commonly with a postero-medial spine.

##### Subfamily CEPHALASPIDINAE Stensiö, 1932

*Diagnosis* (after Denison 1951; letters refer to the parameters used by Denison (1951, p. 161, fig. 20), which are the same as those used in these descriptions). Cephalaspidids in which the thoracic shield is long ( $C/A = 2.4-3.4$ ; cf. 1.9 in *Procephalaspis*) and narrow. The pectoral sinuses are shallow ( $E/A = 1.2-3.4$ ) and the lateral fields have a simple posterior termination.

##### Genus CEPHALASPIS Agassiz, 1835

*Diagnosis*. Cephalaspidids with greatly elongated lateral fields ( $G/A = 3.8-5.3$ ).

##### *Cephalaspis* sp. indet.

Plate 23; text-fig. 67A, B

*Material*. NMC 21551, incomplete cephalic shield associated with trunk and pectoral fin scales (Pl. 23, fig. 1; text-fig. 67A); NMC 21552, incomplete cephalic shield (Pl. 23, fig. 2; text-fig. 67B).

*Locality*. GSC 69014.

---

#### EXPLANATION OF PLATE 23

Figs. 1, 2. *Cephalaspis* sp. indet. 1, incomplete cephalic shield and trunk squamation (NMC 21551),  $\times 2$ .  
2, dorsal surface of incomplete cephalic shield (NMC 21552),  $\times 3$ .  
Fig. 3. Cephalaspididae indet., Type I. Incomplete cephalic shield and trunk squamation (NMC 21553),  $\times 2$ .

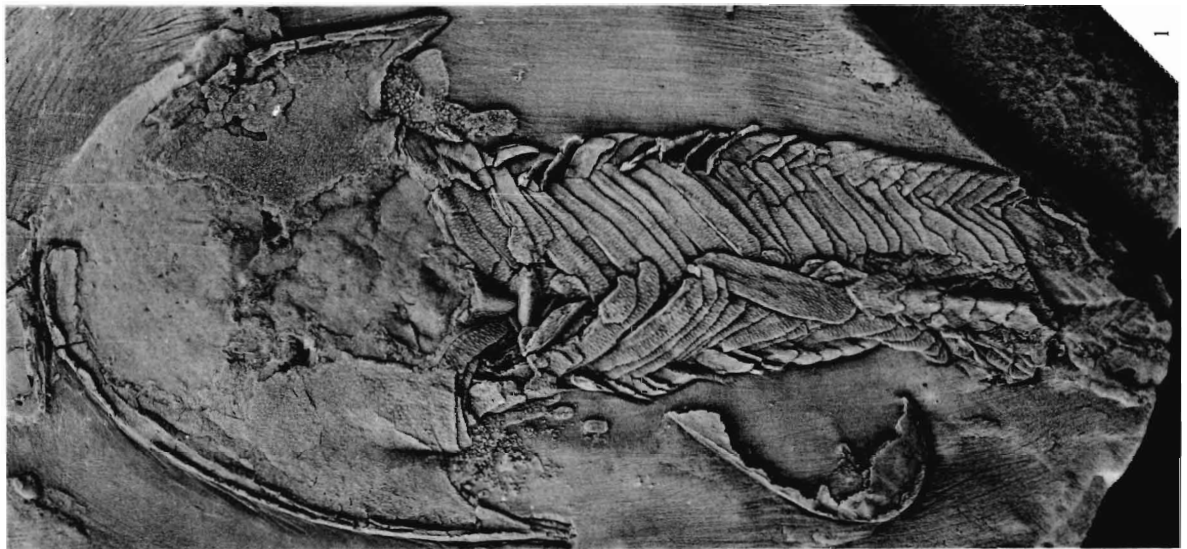
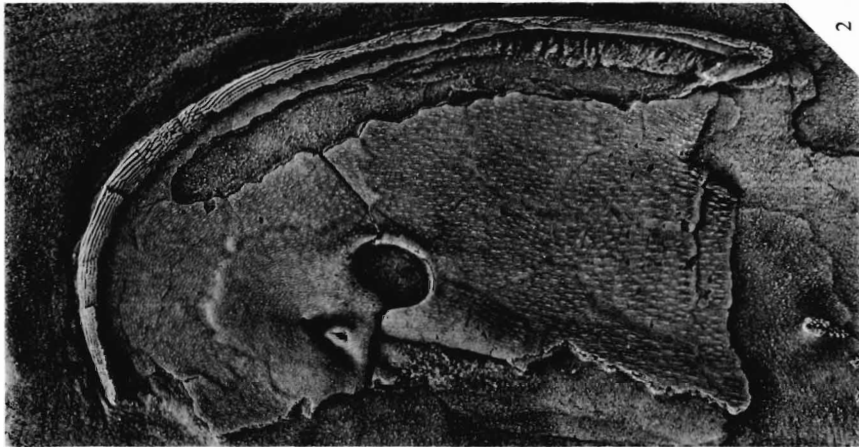
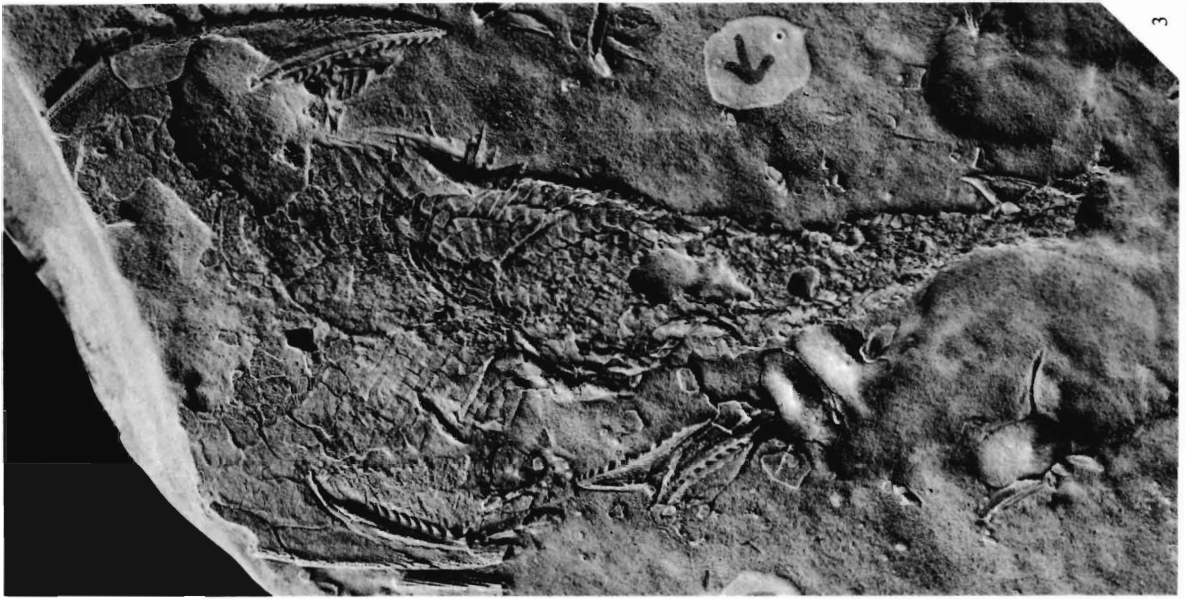

DINELEY and LOEFFLER, Cephalaspids

*Description. Dimensions:*

	NMC 21551 (mm)	NMC 21552 (mm)	Ratios (calculated from averages, where possible):	
A	—	7.0	B/A	2.4
B	14.0	14.0	C/A	2.9
C	20.0	17.0	E/A	1.9
D	15.0	15.5	G/A	3.9
E	13.0	13.5	H/A	5.0
F	1.5	1.5		
G	—	27.0		
H	36.0	34.0		

(i) *Cephalic shield.* Close similarity in shape, size, and ornamentation, indicate that NMC 21551 and 21552 are co-specific; the cornu of the latter is shorter, as a result of crushing.

The rostral margin is broadly rounded, lacking a distinct rostral angle; the cornua are short and have smooth inner margins. Despite the short and narrow (0.2 mm diameter) pectoral sinuses, disarticulated plates (Pl. 23, fig. 1; text-fig. 67B) in the region of the sinus suggest that a pectoral fin existed. The inter-zonal part of the trunk division of the cephalic shield is short; the presence of a dorsal spine cannot be determined, because of the loss of the median part of the posterior of the cephalic shield. The oval orbits, which have a diameter of 3–4 mm, are placed slightly anterior to the middle of the length of the shield.

The lateral fields, which extend back on to the cornua, are covered (in NMC 21551) by polygonal plates (Pl. 23, fig. 1) with ornament identical to that of the rest of the shield. Since the lateral field is not depressed, its extent is more easily determined when the polygonal plates are not preserved (as in NMC 21552; Pl. 23, fig. 2).

The endoskeleton is not visible in either specimen, exposed surfaces being of the exoskeleton only. The superficial layer of the exoskeleton has a characteristic ornament of short ridges (0.5 mm) and circular pores. The infra-orbital lateral line sensory canal is distinguishable as a narrow groove in the superficial layer of NMC 21552 (Pl. 23, fig. 2); other parts of the lateral line system are not seen. The rim of the cephalic shield is thickened and bears an ornament of coarse, flat-topped ridges.

The deep and triangular circum-basal fossa houses separate nasal and hypophysial openings. The former is oval and lies posteriorly on a small nasal elevation; the latter is pear-shaped and occupies a depression at the anterior apex of the fossa.

(ii) *Trunk region.* Part of the scale-covered region behind the cephalic shield is preserved in NMC 21551 (Pl. 23, fig. 1; text-fig. 67B). Dorso-ventral flattening disrupted the scales of the dorsal mid-line. The length of trunk preserved is about 50 mm; it tapers from 20 mm wide anteriorly to 14 mm wide posteriorly. The scale cover of the dorsal surface includes large, dorso-lateral scales, ridge scales, and lateral scales (text-fig. 67B), arranged in scale-rings ('transverse rows' of Stensiö 1932) around the body. The pair of dorso-lateral scales of each ring converge on the dorsal mid-line in a V, the point of which is directed posteriorly. Those of the more anterior scale-rings are of the order of 10–12 mm high and 2.5 mm wide; toward the posterior end

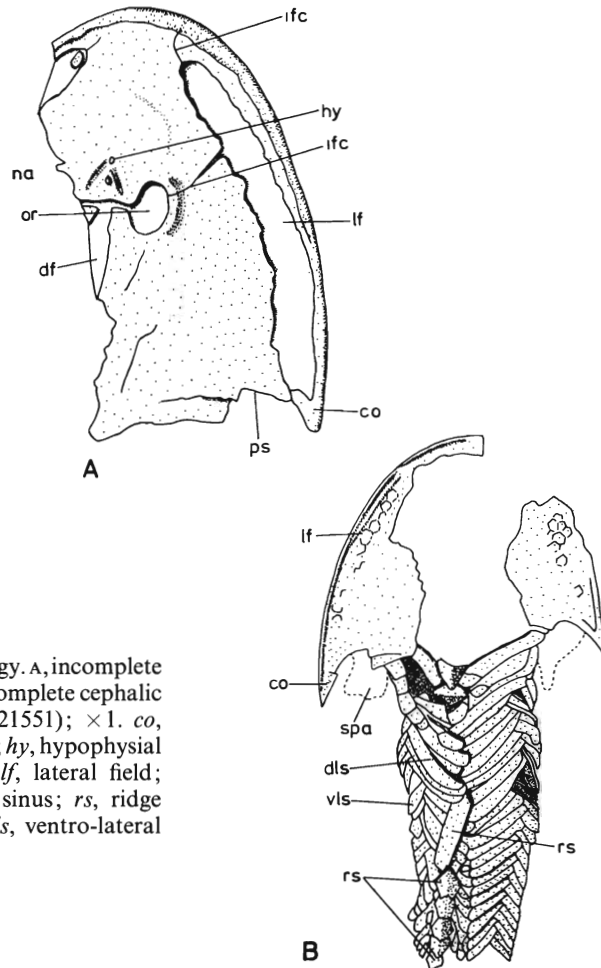

TEXT-FIG. 67. *Cephalaspis* sp. indet., morphology. A, incomplete cephalic shield (NMC 21552);  $\times 1.875$ . B, incomplete cephalic shield with associated trunk scales (NMC 21551);  $\times 1$ . *co*, cornu; *df*, dorsal field; *dls*, dorso-lateral scale; *hy*, hypophysial opening; *ifc*, pores of infraorbital canal; *lf*, lateral field; *na*, nasal opening; *or*, orbit; *ps*, pectoral sinus; *rs*, ridge scale; *spa*, scales of pectoral appendage; *vls*, ventro-lateral scale.

of the trunk, they are of similar width but only half as high. The longer, antero-lateral margin of each dorso-lateral scale bears a narrow (0.5 mm), unornamented overlap margin; the remainder of the scale has an ornament similar to that of the cephalic shield, with short ridges arranged parallel to the length of the body (Pl. 23, fig. 1). On the dorso-ventrally compressed trunk, ventro-lateral scales are obliquely arranged in opposite orientation to the dorso-lateral scales. Of similar width and ornamentation to the dorso-lateral scales, they extend on to the ventral surface of the trunk so that their height cannot now be measured.

A slightly displaced, longitudinal row of symmetrical ridge scales near the posterior end of the trunk region and, anteriorly, isolated ridge scales, suggest that a median crest was present. The five posterior ridge scales, and two of the anterior are of similar type; each is approximately 3 mm long and 2 mm wide and is arched about its longitudinal axis. A remarkable isolated scale lies in the mid-line, in front of the row of articulated ridge scales (Pl. 23, fig. 1). It is 12 mm long and 4 mm wide, with ornament parallel to the long axis. The short, unornamented overlap margin suggests

that this scale was part of the dorsal crest and that it may have been equivalent to the posterior scute in *Hemicyclaspis* (which Stensiö considers equivalent to the dorsal fin of other forms).

*Remarks.* The long thoracic shield, shallow pectoral sinuses, and simply terminated lateral fields require that these specimens should be placed in the Cephalaspidinae; the great length of the lateral fields indicate a species of the genus *Cephalaspis*.

When Denison (1952) reported the presence of separate openings in *C. wyomingensis*, he regarded it as unique. In the same year, however, Wängsjö (1952) described separate openings in *Nectaspis* and in three species of *Cephalaspis* from Vestspitsbergen. Although separate openings are present in all specimens of *C. excellens* Wängsjö, they are present in only some of his *C. eurynotus* and *C. dissimulata*.

This material is excluded from *C. excellens* and *C. dissimulata* by the smooth mesial margins of its cornua, from *C. eurynotus* by the shape of the cephalic shield, and from *C. wyomingensis* by the lack of subdivision of the shield into polygonal units.

*?Cephalaspis gabrielsei* sp. nov.

Plates 24-26; text-figs. 68-71

*Derivation of name.* After H. Gabrielse of the Geological Survey of Canada, collector of much of the material from GSC 69014.

*Diagnosis.* Cephalaspidid of moderate dimensions, with cephalic shield subdivided into polygonal plates. Cornua long, with anteriorly directed denticles on mesial margins; scaled pectoral appendage present in pectoral sinus. Long, barbed, dorsal spine supported by tall, narrow plates, situated immediately posterior to dorsal field.

*Holotype.* NMC 13761, cephalic shield, crushed laterally (Pl. 24; text-fig. 68A).

*Paratypes.* NMC 13764, dorsal spine (Pl. 24; text-fig. 69B); NMC 13765, cephalic shield (Pl. 24; text-fig. 69).

*Other material.* NMC 13762 (text-fig. 70A), 13763 (text-fig. 70B), 13766, crushed cephalic shields, preserved in ventral aspect (see Plates).

*Locality.* GSC 69014.

*Description.* In all of the specimens, only the exoskeleton is visible and crushing has been severe; the headshield is estimated to have been approximately 40 mm long and to have had an intercornual width of over 50 mm. The absence of the superficial layer of the exoskeleton is indicated by the subdivision of the exoskeleton into polygonal plates, the apparent absence of mucous pores, and the absence of dentine cappings on the tubercles.

---

EXPLANATION OF PLATE 24

Figs. 1, 2. *?Cephalaspis gabrielsei* sp. nov. 1, block with numerous articulated specimens (NMC 13761-13764),  $\times 1$  (approx.) (see text-fig. 68). 2, block with numerous articulated specimens (NMC 13765-13766),  $\times 1$  (approx.) (see text-fig. 69).

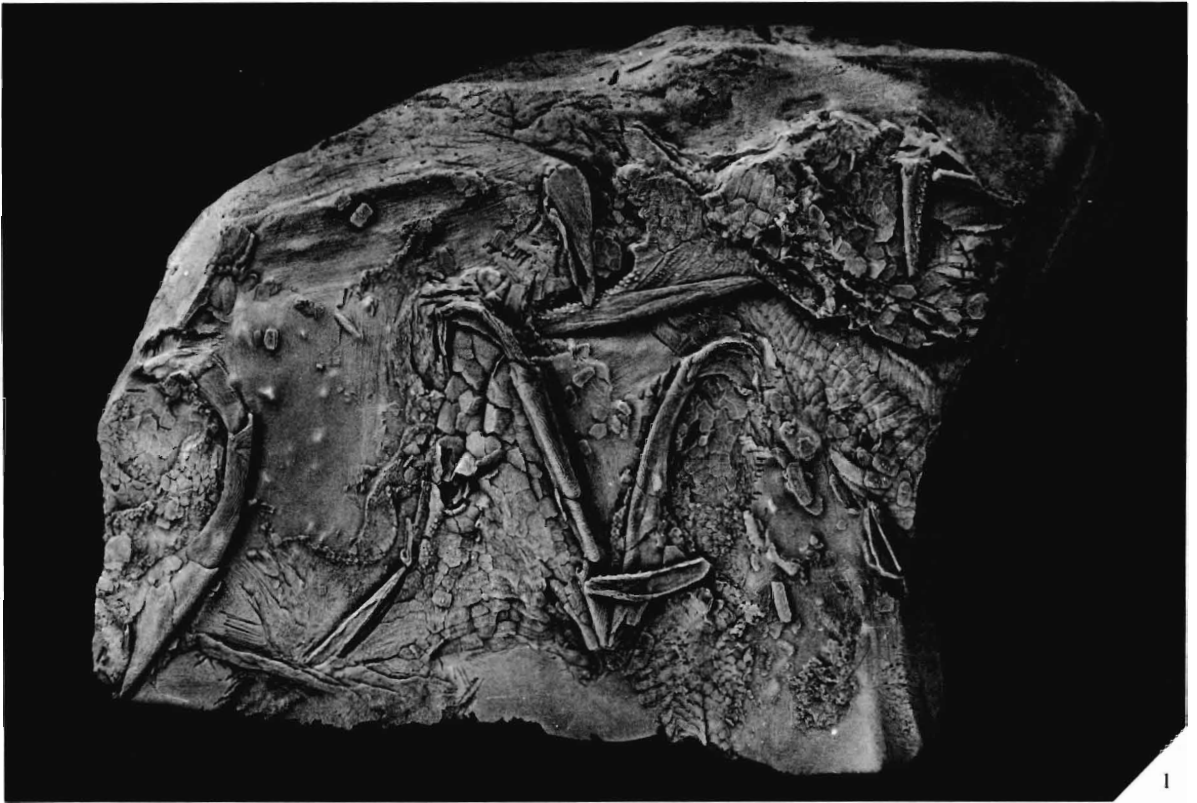

1



2

DINELEY and LOEFFLER, ?*Cephalaspis gabrielsei*



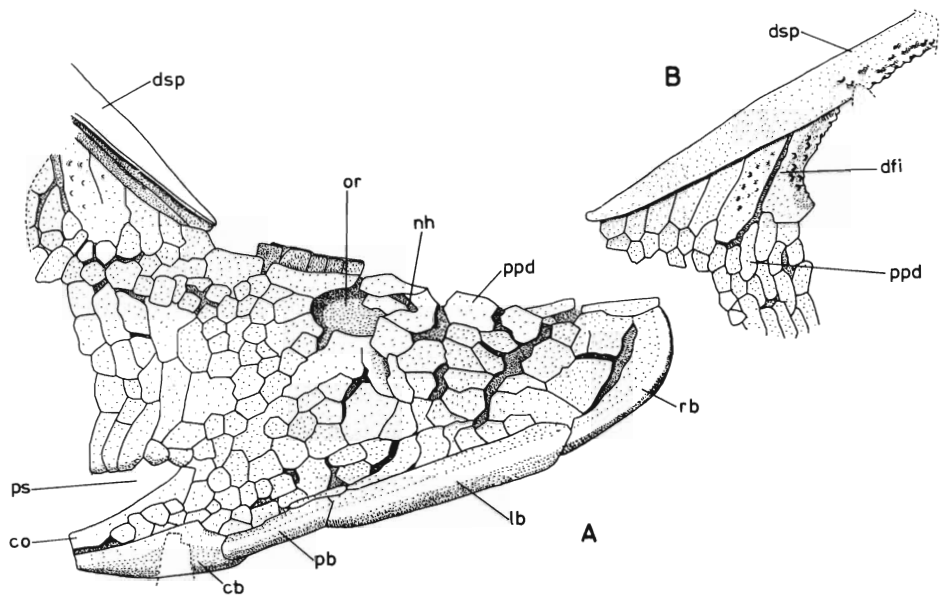

TEXT-FIG. 68. ?*Cephalaspis gabrielsei* sp. nov., morphology. A, crushed cephalic shield (NMC 13761, holotype);  $\times 2$ . B, dorsal fin and spine (NMC 13764, paratype);  $\times 2$ . *cb*, cornual section of cephalic brim; *co*, cornu; *dfi*, dorsal fin; *dsp*, dorsal spine; *lb*, lateral section of cephalic brim; *nh*, naso-hypophysial opening; *or*, orbit; *pb*, pectoral section of cephalic brim; *ppd*, polygonal plates of surface of dorsal shield; *ps*, pectoral sinus; *rb*, rostral section of cephalic brim.

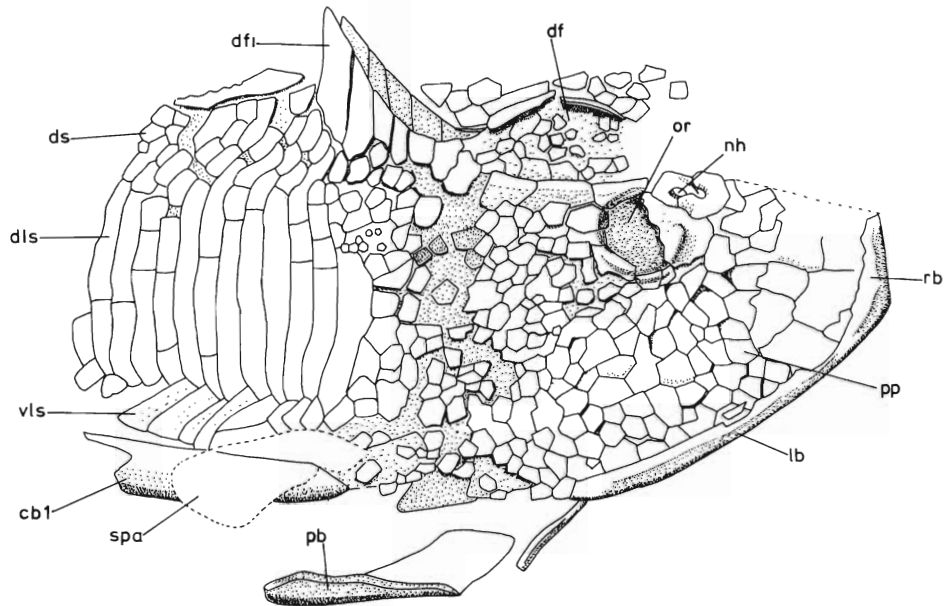

TEXT-FIG. 69. ?*Cephalaspis gabrielsei* sp. nov., dorsal surface of crushed cephalic shield (NMC 13765, paratype);  $\times 2$ . *cb1*, cornual section of cephalic brim; *df*, dorsal field; *dfi*, dorsal fin; *dls*, dorso-lateral scale; *ds*, dorsal scale; *lb*, lateral section of cephalic brim; *nh*, naso-hypophysial openings; *or*, orbit; *pb*, pectoral section of cephalic brim; *pp*, polygonal plates; *rb*, rostral section of cephalic brim; *spa*, scales of pectoral appendage; *vls*, ventro-lateral scale.

On the dorsal surface of the headshield, the separate polygonal plates have become disarranged. The dorsal sensory field is conspicuous, depressed, and covered by small polygonal plates under 1 mm in diameter (text-fig. 70). Situated on two plates, the nasal and hypophysial openings are joined by a narrow slit (Pl. 26). The orbits are large and circular, being bounded laterally by an elevated ridge which extends posteriorly around the lateral margins of the dorsal field (Pl. 25). Immediately in front of the orbit is a small, dome-shaped elevation (text-fig. 69).

The rostral and lateral margins of the cephalic shield and the lateral and mesial margins of the cornua form a thickened brim which also extends ventrally. It is divided into nine separate plates (Pl. 24, fig. 1; text-fig. 70). A single rostral plate forms the anterior border of the cephalic shield, a pair of lateral plates forms the greater part of the lateral margin of the shield and is separated from two pairs of cornual plates (text-fig. 70), by a small pair of pectoral plates. The mesial margin of the posterior cornual plate is bordered by a row of small, anteriorly directed denticles (text-fig. 70). The thick mesial and lateral rims of the dorsal surface of the cornua are separated by a depressed area containing small, polygonal plates (Pl. 26; text-fig. 70);

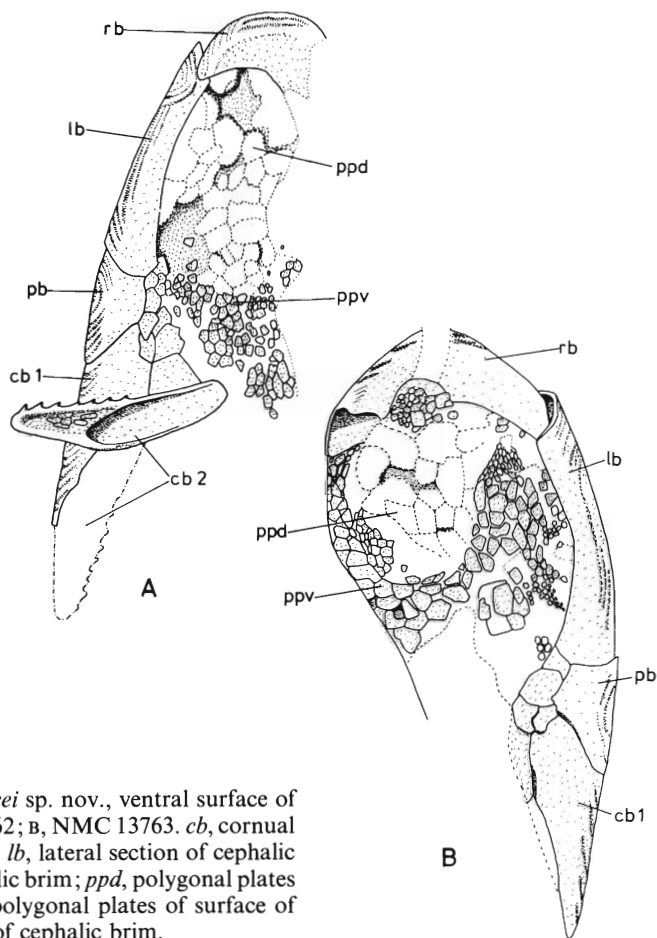

TEXT-FIG. 70. *Cephalaspis gabrielsei* sp. nov., ventral surface of cephalic shields;  $\times 2$ . A, NMC 13762; B, NMC 13763. *cb*, cornual section of cephalic brim (1 and 2); *lb*, lateral section of cephalic brim; *pb*, pectoral section of cephalic brim; *ppd*, polygonal plates of surface of dorsal shield; *ppv*, polygonal plates of surface of ventral shield; *rb*, rostral section of cephalic brim.

the long cornua appear to be directed posteriorly. A pectoral appendage is indicated not only by the deep pectoral sinus, but also by an area of small scales in the pectoral region of NMC 13765 (Pl. 26).

Immediately behind the dorsal sensory field is a well developed, triangular dorsal fin (text-fig. 68B). Its forward margin is a long, narrow plate, which is prolonged posteriorly as a spine; the lateral faces of the fin are formed by several tall, narrow plates. The trailing margin of the fin and spine are ornamented with coarse, dome-shaped tubercles.

On the ventral surface of the shield, the exoskeleton forms a wide lateral brim (text-fig. 70A), also made up of nine separate plates. The visceral exoskeleton comprises numerous small plates which appear to have covered all but a circular, anterior area, presumed to have been the mouth (text-fig. 70B). Neither the branchial openings of the ventral surface of the cephalic shield nor the lateral sensory fields of the dorsal surface are visible, probably because of crushing.

The polygonal plates of the dorsal surface of the headshield are larger anteriorly than posteriorly. The trunk behind the headshield is covered in scales, the division between the two being indistinct (Pl. 26).

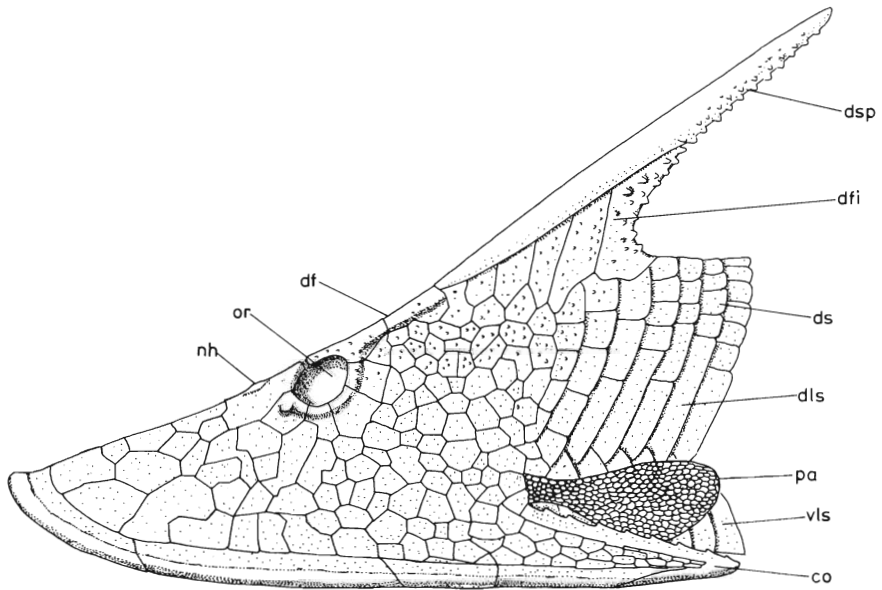

TEXT-FIG. 71. *Cephalaspis gabrielsei* sp. nov., restoration of cephalic shield in lateral view;  $\times 2$ . *co*, cornu; *df*, dorsal field; *dfl*, dorsal fin; *dls*, dorso-lateral scale; *ds*, dorsal; *dsp*, dorsal spine; *nh*, naso-hypophysial opening; *or*, orbit; *pa*, pectoral sinus; *vls*, ventro-lateral scale.

#### EXPLANATION OF PLATE 25

?*Cephalaspis gabrielsei* sp. nov. Laterally compressed cephalic shield (NMC 13761, holotype),  $\times 2.5$  (approx.).



DINELEY and LOEFFLER, ?*Cephalaspis gabrielsei*

The squamation of the trunk includes tall, paired dorso-lateral and ventro-lateral scales arranged in an anteriorly directed V; the dorsal scales are of similar width, but are much shorter (Pl. 26).

*Remarks.* The well-developed cornua, the pectoral appendages, and the dorsal spine indicate a member of the Cephalaspididae.

Denison (1951) subdivided the family into two subfamilies, the Cephalaspidinae and the Benneviastidinae; like individual genera, these are characterized by the proportions of the cephalic shield and the shape of the lateral fields. It is difficult to place the present crushed material within the classification. It is somewhat arbitrarily referred to *?Cephalaspis*, because of their similarity in shape. The distinctive, barbed, dorsal spine and the subdivision of the cephalic shield into separate polygonal plates suffice to characterize a new species, *?C. gabrielsei*.

#### Cephalaspidinae indet.

Plate 27, fig. 1; text-fig. 72B

*Material.* NMC 21554, incomplete cephalic shield.

*Locality.* GSC 69014.

*Description.* Dimensions of the cephalic shield: A, 18 mm; B, —; C, over 37 mm; D, over 35 mm; E, 25 mm; F, 10 mm; G, —; H, 110 mm.

The single specimen is half of a cephalic shield, incomplete both anteriorly and posteriorly. The exoskeleton has a superficial ornament of pustules, each of which is approximately 0.5 mm in diameter and is drawn to a posteriorly directed point (Pl. 27, fig. 1). Pustules are more closely spaced around the orbits, the dorsal field, and the lateral margin of the cephalic shield. The endoskeleton is not visible.

The cornu, although incomplete, is long, and appears to have been posteriorly directed; the pectoral sinus is deep and rather narrow (text-fig. 72B). Both dorsal and lateral sensory fields are depressed and covered by tiny unornamented plates. The lateral field is long and narrow, extending posteriorly on to the cornu (Pl. 28, fig. 1); the dorsal field is 8 mm wide posteriorly, narrowing to the front. The single naso-hypophysial opening is distinct, but the pineal opening has been obscured.

The sensory canal system of the dorsal surface of the shield is represented by narrow, shallow, grooves. The infra-orbital groove, which is continuous throughout its length, extends antero-laterally from the margin of the orbit; after curving antero-medially, it reaches the broken margin of the shield (Pl. 27, fig. 1). One longitudinal and several approximately transverse short sections of sensory canal occur on the post-orbital part of the shield. This part is obscured by the thelodont which adheres to it (Pl. 27, fig. 1).

*Remarks.* The well-developed cornu and pectoral sinus and the simple termination of the lateral field indicate only a member of the subfamily Cephalaspidinae.

---

#### EXPLANATION OF PLATE 26

*?Cephalaspis gabrielsei* sp. nov. Crushed cephalic shield (NMC 13765, paratype),  $\times 3.5$  (approx.).



DINELEY and LOEFFLER, ?*Cephalaspis gabrielsei*

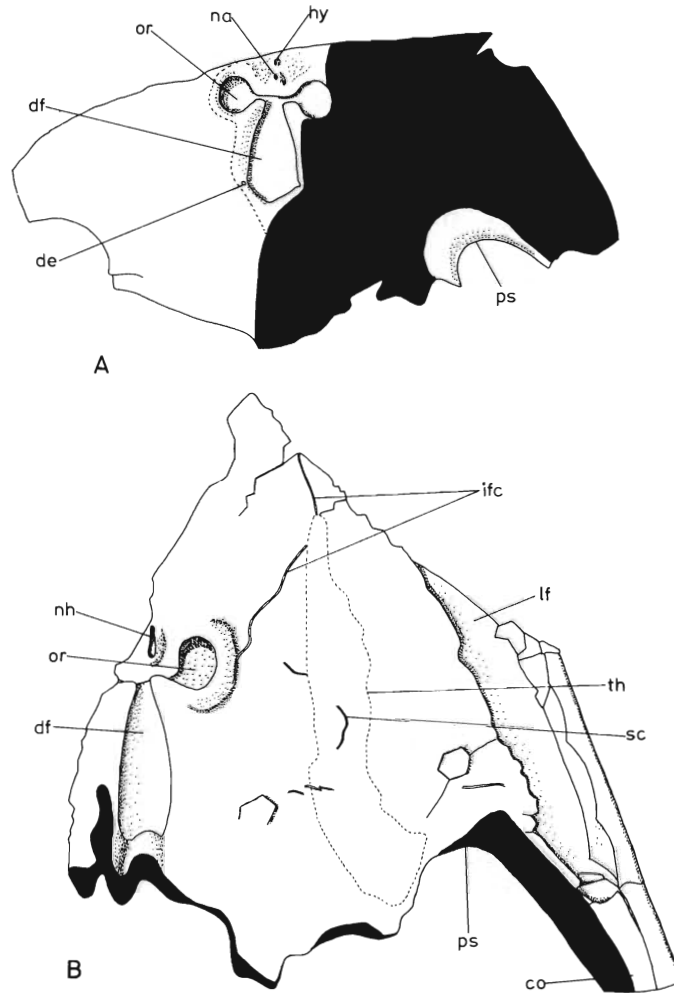

TEXT-FIG. 72. A, Cephalaspidae indet., Type 2, incomplete cephalic shield (NMC 21552);  $\times 1$ ; B, Cephalaspidae indet., Type 2, cephalic shield with adhering thelodont (dotted outline) (NMC 21554);  $\times 1$ . *co*, cornu; *de*, external opening of endolymphatic duct; *df*, dorsal field; *hy*, hypophysial opening; *ifc*, pores of infra-orbital canal; *lf*, lateral field; *na*, nasal opening; *nh*, naso-hypophysial opening; *or*, orbit; *ps*, pectoral sinus; *th*, thelodont; *sc*, sensory canal.

EXPLANATION OF PLATE 27

Fig. 1. Cephalaspidae indet. Incomplete cephalic shield (NMC 21554),  $\times 2$  (approx.).

Fig. 2. Cephalaspidae indet., Type 2. Incomplete cephalic shield (NMC 21555),  $\times 1.75$  (approx.).

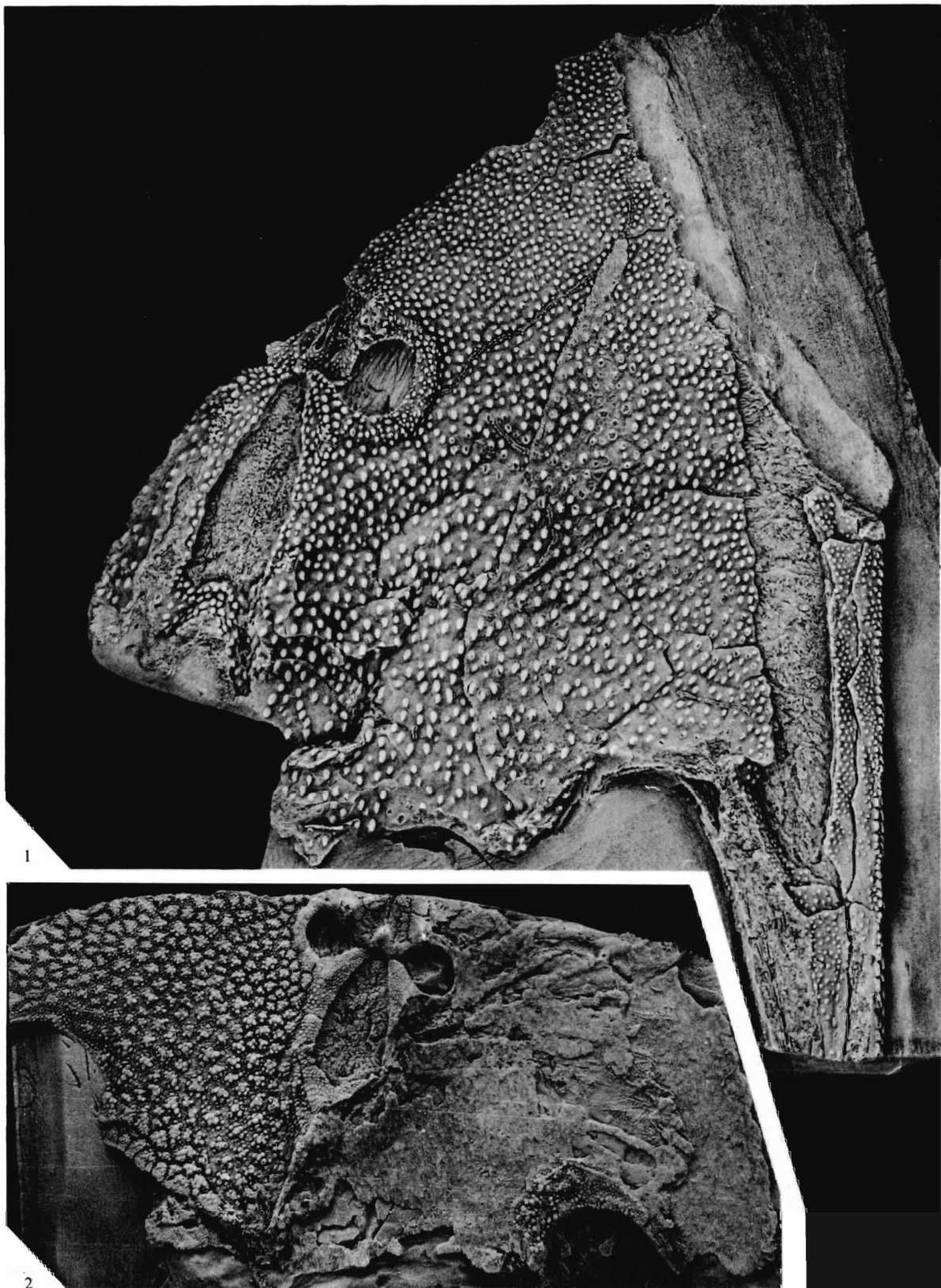

DINELEY and LOEFFLER, Cephalaspids



## Cephalaspididae indet., Type 1

Plate 23, fig. 3

*Material.* NMC 21553, poorly preserved, posterior region of cephalic shield and associated, scale-covered trunk. Isolated cornua, fragments of cephalic shield and scales (unnumbered) on same slab.

*Locality.* GSC 69014.

*Description.* The cephalic shield and trunk scales are articulated, but much of the external surface is weathered. The ventral side is visible and shows the cornua and several of the polygonal plates of the ventral visceral exoskeleton; the internal surfaces of the dorsal exoskeletal plates are locally visible beneath some of the ventral plates. The cornua are long, slender, and posteriorly directed; the distance between their posterior tips is 30 mm. On the mesial margins of the cornua are small (0.4 mm high), anteriorly directed denticles, spaced at intervals of 0.6–0.8 mm. Between the cornua and the trunk, on one side of NMC 21553, are numerous, poorly preserved scales (0.1 mm in diameter), which undoubtedly covered a pectoral appendage.

Owing to poor preservation, little detail of scale arrangement can be ascertained. The internal surface of the dorsal scales, revealed by natural weathering of the ventral scales, shows that some of the former were tall and narrow. On the ventral surface of the trunk, most of the scales are small (approx. 10 mm in diameter) and rhomboidal, but the tall dorsal scales extend ventrally and form lateral keels.

The external surface of the exoskeletal plates and scales is covered with small pores, which are coarsest on the margins of the cephalic shield and on the lateral keels of the trunk. The endoskeleton seems not to have been preserved.

The animal is estimated to have been rather small, with a total length of approximately 70 mm. The headshield is broad and the cornua long; the trunk is 20 mm wide immediately posterior to the pectoral sinuses.

*Remarks.* Pectoral sinuses, cornua, and pectoral appendages indicate that this specimen is a member of the Cephalaspididae. Since it is too poorly preserved to refer to a smaller taxon, it is regarded as Cephalaspididae indet., Type 1.

## Cephalaspididae indet., Type 2

Plate 27, fig. 2; text-fig. 72A

*Material.* NMC 21555, an incomplete cephalic shield.

*Locality.* GSC 69014.

*Description.* Dimensions: A, 14.5 mm; B, —; C, 30.0 mm; D, 27.0 mm; E, 17.0 mm; F, 10.0 mm.

The cephalic shield is estimated to have been short and broad; the cornua are wide, long, and postero-laterally directed, and the pectoral sinuses are broad and shallow. The short, depressed dorsal sensory field retains a cover of small plates; it is widest (8 mm) posteriorly, narrowing gently to the anterior end (Pl. 27, fig. 2; text-fig. 72A). A narrow, longitudinal elevation, extending from the posterior margin of the dorsal field to the hind margin of the cephalic shield, probably represents the base of the dorsal spine. The exoskeleton is well preserved on only one half of the shield; its

superficial ornament is in the form of clusters of tubercles elevated above a background of finer tubercles. Around the orbits and dorsal field, the bone is thick and cancellous. The circum-nasal fossa is triangular and houses separate nasal and hypophysial openings. The slit-like hypophysial opening lies in a hollow at the anterior apex of the fossa, and the oval nasal opening is situated on a posterior, nasal elevation. The external openings of the endolymphatic ducts lie on the edge of the dorsal field, at its maximum width (text-fig. 72A).

*Remarks.* The dorsal spine, cornua, and pectoral sinuses indicate that this specimen is a member of the Cephalaspididae. Because it is so poorly preserved, it cannot be placed in a smaller taxon but is referred to Cephalaspididae indet., Type 2, which is distinguished from Type 1 by its smaller size, greater relative breadth and the presence of separate nasal and hypophysial openings.

#### Indeterminate Cephalaspididae and Osteostraci

Like the better material with which some may be cospecific, the following poorly preserved specimens are from GSC locality 69014. Members of the Cephalaspididae are recognized by their well-developed cornua and pectoral sinuses.

##### *Cephalaspididae indet.:*

1. NMC 21556. Part of the lateral brim of a large cephalic shield with slender well-developed cornua.
2. NMC 21564. Isolated cornu with small, anteriorly directed denticles on mesial margin.
3. NMC 21565. Poorly preserved brim of a large cephalic shield, lacking rostral angle but having well-developed cornua.
4. NMC 21566. Long cornu with denticles on mesial margin becoming smaller and more closely spaced toward posterior.

##### *Osteostraci indet.:*

1. NMC 21557. Part of lateral brim of cephalic shield with porous exoskeleton.
2. NMC 21558. Part of the lateral brim of a cephalic shield, possibly of the same type of NMC 21557.
3. NMC 21559. Part of brim of cephalic shield, with ornament of serrated ridges.
4. NMC 21560. Fragment of dorsal surface of cephalic shield, with exoskeleton divided into polygonal plates.
5. NMC 21561. Fragment of dorsal surface of a large cephalic shield in internal aspect, only the exoskeleton being preserved. Nasal and hypophysial openings are separate.
6. NMC 21562. Fragment of exoskeleton of pre-pineal region, subdivided into polygonal areas, and the nasal and hypophysial openings separate.
7. NMC 21563. Fragment of lateral margin of cephalic shield.

#### GENERAL COMMENTS ON THE OSTEOSTRACI

##### *Biostratigraphic and palaeoecological significance of Cephalaspis*

All identifiable osteostracans from GSC locality 69014 belong to the Cephalaspididae; those which can be referred to smaller taxa belong to the subfamily Cephalaspidinae or to the genus *Cephalaspis*. None of the features of the unidentifiable material exclude it from *Cephalaspis*.

*Cephalaspis* is a long-ranging genus, occurring in rocks from Late Silurian to Middle Devonian in age. Osteostraci from the Late Devonian of Quebec, originally referred to *Cephalaspis* (Traquair 1890; Robertson 1936), were removed by Ørvgil (1957) to *Escuminaspis*, which is a *nomen nudum*. *Cephalaspis* is common in the Early

Devonian of Vestspitsbergen, being well known from the monographic studies by Stensiö (1927) and Wängsjö (1952). The genus makes its debut in the lowest fossiliferous horizon of the Fraenkelryggen Formation and extends through the Fraenkelryggen, Ben Nevis, and Wood Bay Formations. In Britain, *Cephalaspis* (Stensiö 1932) makes its first appearance in the zone of *Traquairaspis symondsi* (Ball and Dineley 1961), continuing up into the Middle Old Red Sandstone in Scotland (Traquair 1894). From the rich osteostracan fauna in the Chortkov Horizon and Old Red Group of Podolia, only two species have been described (Wängsjö 1952, p. 584, and references therein).

Despite such detailed study, the genus *Cephalaspis* has been of little value in correlation. Species are numerous and have largely been based on minor differences in shape, which are difficult to discern in poorly preserved material. Although fifty-eight species of *Cephalaspis* have been recognized from Vestspitsbergen (Wängsjö 1952) and twenty-one from Britain (Stensiö 1932), only two species are common to both areas and at least one of these occurs at a higher horizon in Vestspitsbergen than in Britain (Halstead and Turner, 1973).

Apart from Ørvig's (1957) *nomina nuda*, *Escuminaspis* and *Alaspis*, from the Late Devonian of Quebec, and *Hemicyclaspis* from the Peel Sound Formation of Somerset Island, all of the North American Osteostraci have been referred to *Cephalaspis*. In eastern Canada there is a species of *Cephalaspis* in the Knoydart Formation (Denison 1955; Dineley 1967), three in the (?Middle Devonian) Atholville Beds (Traquair 1890, 1893; Robertson 1936) and eight in the (?Middle Devonian) Gaspé Sandstone (Lankester 1870; Russell 1947; Pageau 1968, 1969). Indeterminate species of *Cephalaspis* have also been reported from the Peel Sound Formation of Somerset Island (Dineley 1968a), and material from the adjacent Prince of Wales Island remains to be described. In Wyoming and Utah, three species of *Cephalaspis* are known from strata which are correlated with the Siegenian (Denison 1952, 1960, and refs. therein).

*Cephalaspis* may be useful as an indicator of fresh water or of reduced salinities; Denison (1956) believed that the Osteostraci, excepting *Sclerodus*, were restricted to fresh and brackish water throughout their history. During the Ludlovian, primitive Osteostraci such as those of Oesel, Norway, and the Scottish inliers, inhabited marginal brackish or fresh-water environments. In the Downtonian and Devonian, Osteostraci were most common in stream deposits; rare marine occurrences were considered to represent individuals carried by streams into the sea.

At GSC locality 69014, the invertebrate fauna and lithology are indicative of hyposaline lagoonal conditions. The Osteostraci, being numerous and including articulated specimens, appear to have lived in that environment rather than to have been washed in.

It seems probable that Osteostraci, although occupying fresh-water environments elsewhere, were, in North-west Canada at least, euryhaline forms which retained the ability to live in brackish water.

#### *Growth and development of the headshield in the Osteostraci*

Denison (1952) examined the inference that, since the osteostracan shield is generally a sutureless capsule in which indications of resorption and redeposition of bone are rare, it can only have been acquired after the animal was full-grown. Using a statistical

approach, he concluded that *Tremataspis*, *Aceraspis*, *Micraspis*, *Thyestes*, and *Didymaspis* did not continue to grow after the shield had formed; evidence was inadequate or non-committal in *Hemicyclaspis* and *Cephalaspis*.

In *Tremataspis*, Denison (1952) demonstrated that bone formed first in the outer layer of the shield and around the canals of the pore-canal system, later in the middle layer; the basal layer was formed below, as successive lamellae. The outer layer, unlike the middle and basal layers, shows no signs of resorption and redeposition of bone; this suggests that growth ceased after the completion of the outer layer (Miles 1971). It is not known whether growth was possible in forms in which the outer layer was reduced or absent.

The separate polygonal plates of the headshield of ?*C. gabrielsei* warrant histological examination to determine whether they grew independently. There is some evidence to suggest that the later representatives of the Osteostraci developed independently growing polygonal plates. They are present in the orbital region of the Middle Devonian *C. magnifica* (Westoll 1974, pers. comm.) and comprise the entire cephalic shield of the Upper Devonian *Alaspis macrotuberculata* nom. nud. (Ørvig 1968). In the latter, the polygonal plates are small, independently growing, suturally interconnected, and have outer, middle, and basal layers. Ørvig (1968) has suggested that the Osteostraci, during their phylogeny, passed through a cycle of skeletal assimilation and regression. Evidence for his 'primary micromeric' and 'primary mesomeric' stages are lacking, typical osteostracans having a 'macromeric' dermal armour. Ørvig (1968) considered the condition of *Alaspis* to correspond to a 'secondary mesomeric' stage of skeletal regression into which the cephalic shield entered late in the history of the group. Whether ?*C. gabrielsei* was one of the first osteostracans to break out of the restrictions imposed by a solid cephalic shield, or whether it was a relic of an earlier evolutionary stage, remains debatable.

#### INCERTAE SEDIS

##### Genus *LEPIDASPIS* gen. nov.

*Diagnosis.* Cephalothorax broad and flat, tail narrow. Armour of small scale-units with basal plates more or less fused. Superficial ornament of barbed ridges; one ridge per basal plate on cephalothorax, two or more per basal plate on the tail. Anterior and lateral margins of cephalothorax thickened; dorsal and ventral surface of caudal region with median row of compound scales. Mouth semicircular and placed antero-ventrally; orbits small, dorsal, and placed antero-laterally. Lateral line system of external pores and internal network of discontinuous grooves.

*Type species.* *Lepidaspis serrata* gen. et sp. nov.

##### *Lepidaspis serrata* gen. et sp. nov.

Plates 28-33; text-figs. 73-77

*Diagnosis.* As for genus, this being the only species.

*Holotype.* NMC 19879, crushed, incomplete cephalothorax, prepared to show dorsal and ventral surfaces (Pl. 28; text-fig. 76B).

*Paratypes.* NMC 19878, fragment of rostrum prepared to show mouth (Pl. 28, fig. 3); NMC 19873, posterior body and tail region (Pl. 30); NMC 19891, tail fragment (Pl. 32, fig. 1); NMC 19882, cephalothorax with lateral lamina and isolated tail scales (Pl. 29).

*Other material.* Seventy-five fragments of carapace (NMC 19870–19872, 19874–19877, 19880–19881, 19883–19887, 19899–19909, 19911–19915, 19917–19936, 21424, 21472–21483, 21508–21509). Isolated denticles (unnumbered) (Pl. 32, figs. 3–8).

*Type locality.* GSC 69014. (All material except that listed under other localities.)

*Other localities.* GSC 81051 (NMC 19899, 19914, 19874); GSC 81057.

*Description.* The outline of the carapace resembles that of *Drepanaspis* (Obruchev 1943), which Tarlo (1962c) likened to a table-tennis bat. The cephalothorax is estimated, from combined measurements of NMC 19879 and 19873, to have been about 70 mm wide and 110 mm long, rather square, with rounded antero-lateral and postero-lateral corners. The caudal region is estimated from NMC 19873 to have been approximately 30 mm wide and over 80 mm long. All of the material is dorso-ventrally flattened and the bone is crushed.

(i) *Cephalothorax.* The orbits, which have a diameter of approximately 3 mm, lie on the antero-lateral margin of the dorsal surface of the cephalothorax and appear to have been dorso-laterally directed (Pl. 28). The armour of the dorsal surface of the cephalothorax is largely in the form of scale-units, which exhibit varying degrees of fusion to one another. Each unit comprises an oval basal plate, approximately 2 mm wide and 3–14 mm long, with a single barbed ridge extending along the length of its external surface (text-fig. 73); isolated scale-units from GSC locality 81057 are shown in Plate 32. Although superficial ridges remain separate, the basal plates of adjacent units are commonly fused. Even where fusion is complete, sutures between adjacent basal plates are distinguishable. The superficial ridges, which are slightly shorter than their basal plates (Pl. 31), are between 0.5 and 1.0 mm high. They are seldom curved or branched, and the lateral barbs commonly extend forward from the central axis at a low angle.

On the anterior and lateral margins of the cephalothorax, and around the orbits, the armour differs from that of the rest of the dorsal surface (Pl. 32); superficial ridges are more closely spaced, the sutures between individual basal plates are not distinguishable, and the bone is relatively thick. In NMC 19874 the lateral margins of the cephalothorax and the orbital areas are preserved in association with a few scale-units, the basal plates of which are not fused; orbital fragments and parts of the lateral margins of the cephalothorax are commonly preserved in isolation (NMC 19875, 19904, 19926, 19930).

#### EXPLANATION OF PLATE 28

Figs. 1–3. *Lepidaspis serrata* gen. et sp. nov. 1, dorsal surface of incomplete cephalothorax (NMC 19879, holotype),  $\times 1.4$  (see text-fig. 76). 2, ventral surface of incomplete cephalothorax (NMC 19879, holotype),  $\times 1.4$ . 3, sub-rostral region, showing oral region with cover of small plates (NMC 19878, paratype),  $\times 2$ .



DINELEY and LOEFFLER, *Lepidaspis serrata*

The orientation of superficial ridges on the dorsal surface of the cephalothorax is irregular. Although the ridges are generally parallel to the margins of the cephalothorax, there are numerous irregularities (Pl. 32). The lateral barbs of a single ridge typically diverge from the central axis at a low angle and point forward; exceptionally, a few ridges have posteriorly directed barbs. On many fragments of the cephalothorax,

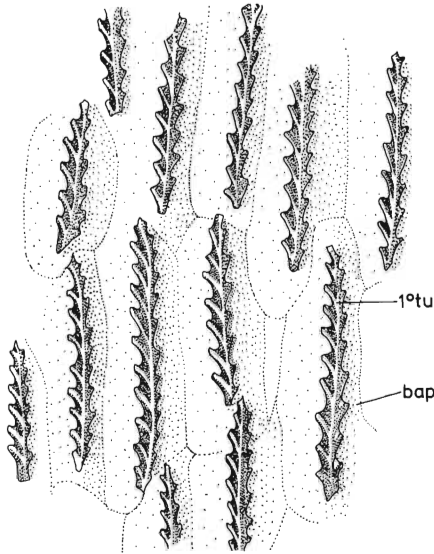

TEXT-FIG. 73. *Lepidaspis serrata* gen. et sp. nov., detail of scale-units (NMC 19882, paratype);  $\times 7.5$ ,  $1^{\circ}tu$ , primary tubercle; *bap*, basal plate.

particularly those from the anterior and lateral margins, superficial ridges are locally short and broad. Such ridges are undoubtedly of secondary eruptive dentine; they commonly overgrow or are interspersed with abraded ridges.

Two specimens (NMC 19878, Pl. 28, fig. 3; NMC 19879, Pl. 28, fig. 2) in which the dorsal surface of the rostrum was intact were prepared to show detail of the ventral surface. In the holotype a triangular process with an ornament of barbed dentine ridges curves beneath the orbital foramen (Pl. 28, fig. 2). The absence of this process in NMC 19873 (Pl. 28, fig. 3) is undoubtedly a result of damage; in this specimen the orbit perforates the dorsal surface of the cephalothorax and is visible from the ventral surface. The anterior margin of the rostrum curves beneath the dorsal surface to form a narrow maxillary brim which is continuous with the anterior of the orbital process in NMC 19879 (Pl. 28, fig. 2). Behind the orbital process the thick lateral margin of the cephalothorax projects ventrally as a ventro-lateral lamina. On its

external surface the barbed ridges are closely spaced, and separate basal plates are not distinguishable. On the internal surface of the lamina, basal plates are not extensively fused and the scale-units are disrupted; this suggests that the cover of scale-units was originally continuous around the body from dorsal to ventral surface, and has been flattened.

The ventral surface of the cephalothorax, posterior to the mouth, is similar in appearance to the dorsal (Pl. 28, fig. 2). The basal plates of adjacent scale-units are largely fused, but the sutures between them are commonly visible. In both NMC 19878 and 19879 (Pl. 28, fig. 2; text-fig. 74), dentine ridges are broader than on the dorsal surface and appear to be of secondary, eruptive dentine.

In NMC 19879 (Pl. 28, fig. 2) the majority of the superficial ridges of the ventral surface are arranged elliptically about the long axis of the body. In the rostral region, however, several rows of ridges are arranged in a posteriorly convex arc. The semi-

#### EXPLANATION OF PLATE 29

*Lepidaspis serrata* gen. et sp. nov. Associated scale-units with lateral lamina (left) and caudal scale-units (bottom) (NMC 19882, paratype),  $\times 2$  (see text-fig. 76).



DINELEY and LOEFFLER, *Lepidaspis serrata*



circular area, enclosed between this arc and the maxillary brim, is interpreted as the mouth. In NMC 19879 the oral region is roofed by the fused basal plates of the scale-units of the dorsal surface. To this roof adhere several small plates (1 mm diameter), some of which bear finely branched superficial ridges. In NMC 19878 numerous small plates cover the whole oral region (Pl. 28, fig. 3). Each plate bears a small, finely branched tubercle.

In the absence of orbits and mouth, it is impossible to determine whether some of the specimens, comprising extensive sheets of more or less fused scale units, were

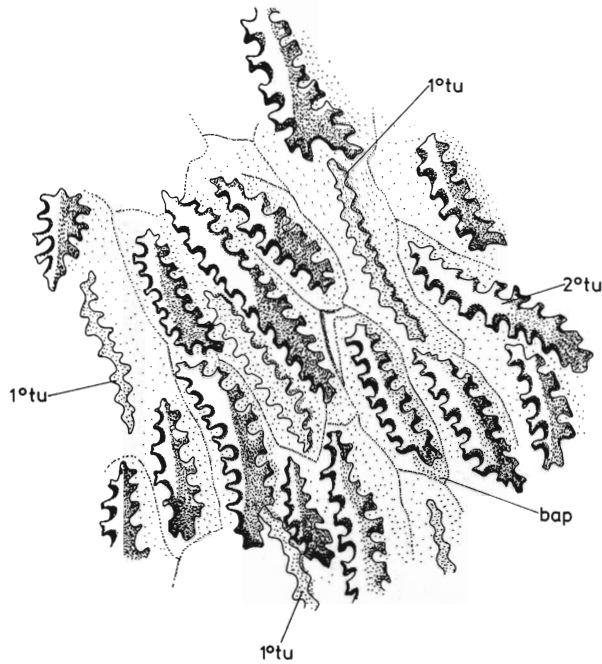

TEXT-FIG. 74. *Lepidaspis serrata* gen. et sp. nov., detail of scale-units showing overgrowth of abraded primary tubercles by broad secondary tubercles on ventral surface of cephalothorax (NMC 19879, holotype);  $\times 7.5$ .  $1^{\circ}tu$ , primary tubercle;  $2^{\circ}tu$ , secondary tubercle; *bap*, basal plate.

dorsal or ventral in position. The arrangement of scale-units in these specimens (NMC 19881–19882, 19884–19886, 21427) is remarkably constant. The lateral barbs of the superficial ridges point forward and, apart from a tendency to anterior and posterior convergence, the ridges are arranged in longitudinal rows. Some of these sheets of scale-units are associated with thickened lateral laminae, e.g. NMC 19882 (Pl. 29), NMC 21472 (Pl. 31, fig. 2), and with caudal scales (NMC 19882 (Pl. 29)). Within the series of specimens NMC 19881, 21472, 19882, 19884, a sequence of progressive fusion of the basal plates of the scale-units can be traced. In NMC 19881 the basal plates are completely separate from one another; in NMC 21472 they are fused only along the lateral margins; in NMC 19882 small gaps remain at the front and rear of the basal plate; in NMC 19884 these have been almost eliminated.

(ii) *Caudal region*. The scale cover of the caudal region, although comprising basal plates and superficial dentine ridges, differs from that of the cephalothorax. The basal plates of the scale-units are short and broad (approximately  $3 \times 3$  mm) and each bears two or three short, barbed ridges on its external surface (Pl. 30; Pl. 32, fig. 1). Preservation of the caudal region is generally poor, but in NMC 19891 (Pl. 32, fig. 1) the basal plates of at least some of the scale-units are fused, small tubercles being present on the sutures (*stu* in text-fig. 75).

On both the dorsal and ventral surfaces of the caudal region, a median row of 'compound' scales extends along the length of the tail. Each compound scale is approximately 10 mm long and 4 mm wide and is gently arched across its longitudinal axis; on the external surface are numerous barbed ridges, with a symmetrical arrangement. The lateral barbs of the ridges, of both the caudal scale-units and the compound scales, diverge from the axis of the ridge at a low angle and point anteriorly. The ridges of the compound scales, like those of the lateral margins of the cephalothorax, are rather more closely spaced than elsewhere.

In NMC 19873 (Pl. 30) the caudal region of the specimen on the left is laterally compressed; one lobe of the tail is expanded, but it is not known whether this is dorsal or ventral. The posterior end of the tail is not complete in any of the specimens. In NMC 19873a (Pl. 30) the median row of compound scales appears to bifurcate posteriorly, but this may be an artefact of preservation; the tail region is poorly preserved and may be twisted in such a way that some of the compound scales are displaced.

(iii) *Lateral line system*. Pores in the basal plates of the scale units of the dorsal surface of the cephalothorax of the holotype (NMC 19879) are thought to be part of the lateral line system; each is of the order of 0.3 to 0.4 mm in diameter and is surrounded by an elevated rim (text-fig. 76A). The pores occur in small groups and give no indication of the pattern of lateral line canals.

Smaller pores, without elevated rims (Pl. 32, fig. 5) are developed on both the internal (Pl. 32, fig. 5) and external (Pl. 32, figs. 6-8) surfaces of the basal plates. They may also have been part of the lateral line system.

A cephalothorax (NMC 21477; Pl. 32, fig. 3), in which the internal surface of the basal plates of the scale-units is exposed, reveals a discontinuous system of narrow grooves which are presumed to be traces of the lateral line canals (text-fig. 77). The grooves, which are 0.5 mm in width and up to 11 mm long, are commonly continuous across the basal plates of several scale-units. The arrangement appears to be a simple, discontinuous network including medial and lateral longitudinal canals and transverse commissures. Unfortunately it is not known whether this is the interior of the dorsal or of the ventral surface of the cephalothorax.



TEXT-FIG. 75. *Lepidaspis serrata* gen. et sp. nov., detail of scale-units in caudal region, with sutural tubercles (*stu*) on margins of adjacent basal plates (*bap*) (NMC 19891);  $\times 7.5$ . *bap*, basal plate; *stu*, sutural tubercle.

(iv) *Ornamentation*. Individuals have a variety of ornamentation, the greatest differences being between the primary and the secondary ridges. Primary ridges (Pl. 31; text-fig. 73) are long (3–14 mm) and narrow (0.5 mm) with a well-developed system of superficial crests extending along the lateral barbs and the long axis of the ridge; the lateral barbs are simple and project from the ridge at a low angle. The secondary ridges (Pl. 32; text-fig. 74), which commonly overlie, or are interspersed with, abraded primary ridges, are long (4–8 mm) and broad (up to 2 mm) with smooth, flat surfaces; their lateral barbs are relatively short, bulbous, and commonly bi-lobed, and extend from the ridge at a high angle.

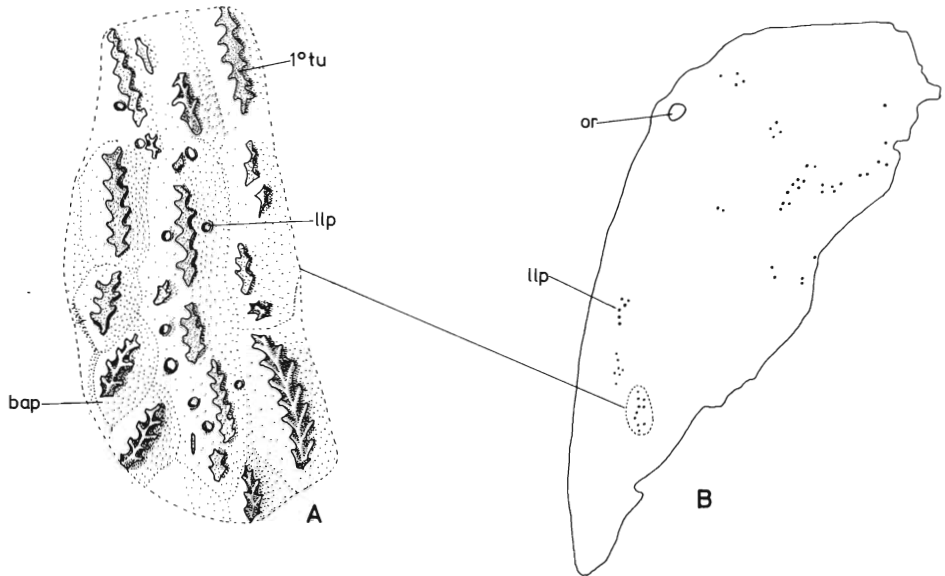

TEXT-FIG. 76. *Lepidaspis serrata* gen. et sp. nov., lateral line pores of dorsal surface of cephalothorax (NMC 19879, holotype). A, detail of lateral line pores;  $\times 7.5$ ; B, cephalothorax, plan view;  $\times 1$ . *bap*, basal plate; *1°tu*, primary tubercle; *llp*, lateral line pore; *or*, orbit.

*Remarks.* (a) *Oral region*. Because the dorsal and ventral surfaces of the cephalothorax of NMC 19878 and 19879 are so closely pressed together, it is possible to advance two interpretations of the denticle-covered oral region:

1. The small scale-units of the semicircular oral region were set in a membrane, which covered the oral region and which may have been protrusible. Such a membrane would, presumably, have been continuous posteriorly with the underside of the cephalothorax. As a result of dorso-ventral flattening, ventral scale-units have adhered to the internal surface of the dorsal armour.

#### EXPLANATION OF PLATE 30

Figs. 1, 2. *Lepidaspis serrata* gen. et sp. nov. 1, incomplete cephalothorax and tail (two specimens) (NMC 19873a and b, paratypes),  $\times 1.2$ . 2, caudal region (NMC 19674),  $\times 1.5$ .

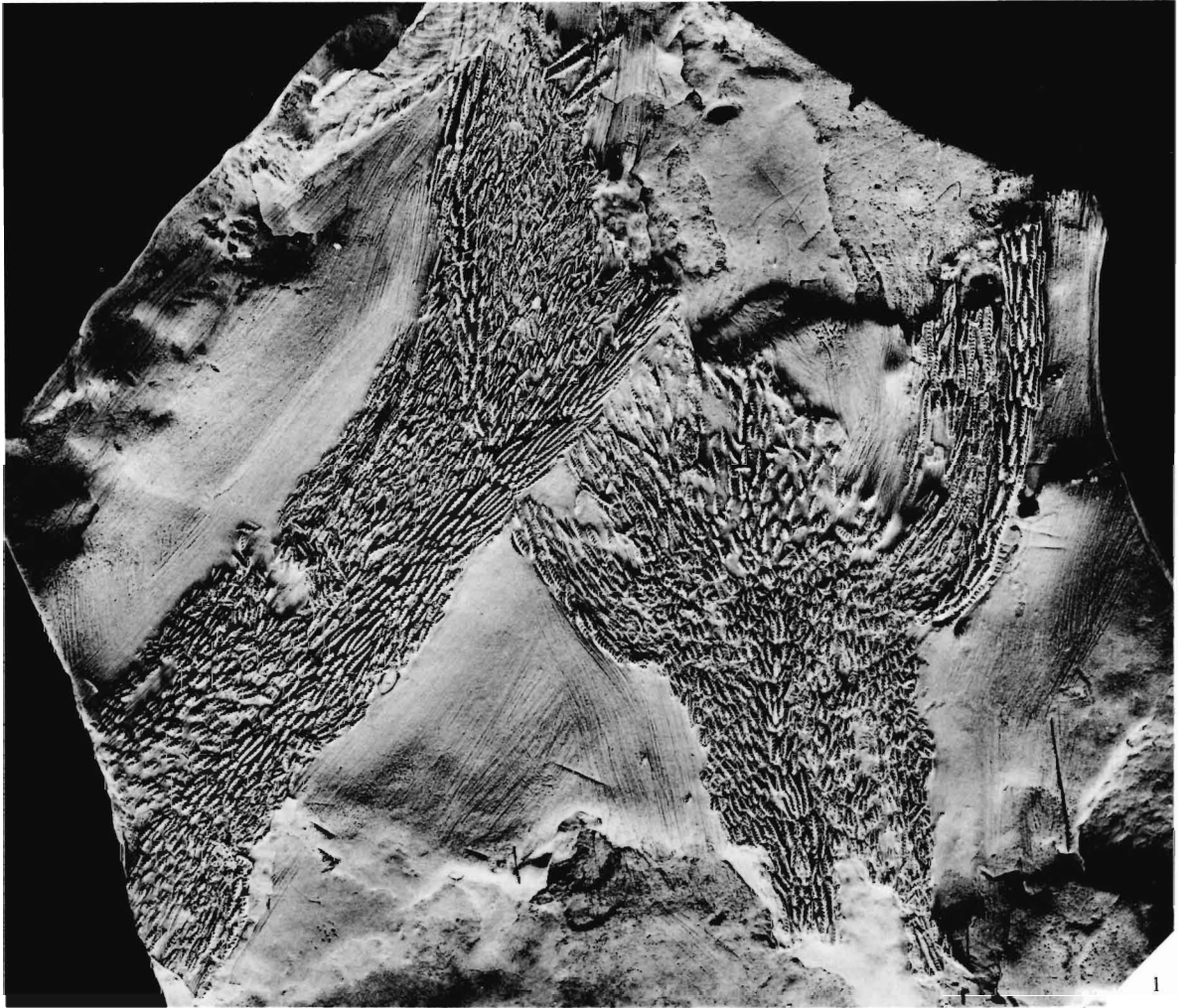

DINELEY and LOEFFLER, *Lepidaspis serrata*

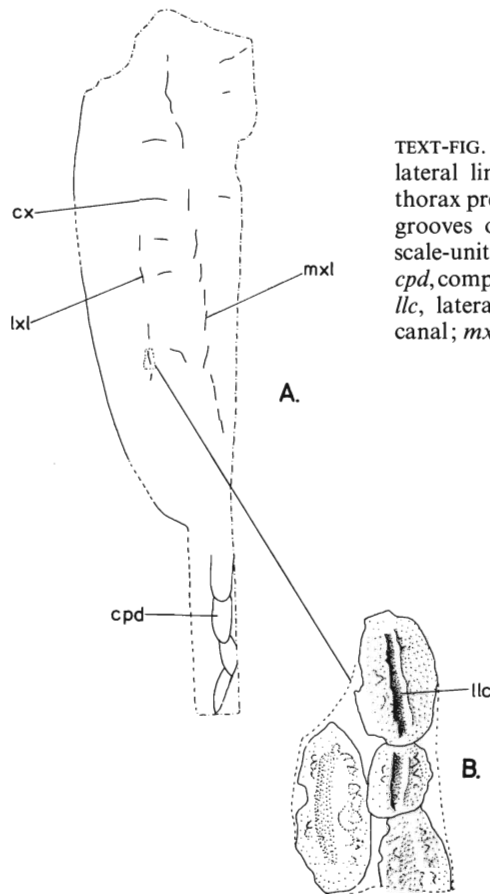

TEXT-FIG. 77. *Lepidaspis serrata* gen. et sp. nov., lateral line canals (NMC 21477). A, cephalothorax preserved in reverse, showing a system of grooves on internal surface of basal plate of scale-units;  $\times 0.5$ ; B, detail of grooves;  $\times 7.5$ . cpd, compound scale; cx, transverse commissure; llc, lateral line canal; lxl, lateral longitudinal canal; mxl, median longitudinal canal.

2. The scale-units of the oral region formed a palate-like area in the roof of the mouth and were not connected with the external armour of the ventral surface of the cephalothorax.

By analogy with the Heterostraci, both interpretations are plausible. A palate-like area (the pre-oral field) existed in some pteraspids, where it is regarded as having been the site of pre-oral sensory structures (Denison 1967*b*). In the Pteraspidae a protrusible oral cover, strengthened by oral plates (Heintz 1962), is presumed to have formed a scoop for feeding on soft bottom sediments.

(*b*) *Mode of life*. The cephalothorax is dorso-ventrally flattened in all specimens, suggesting that this was to some extent true of the living animal. Lack of evidence of

#### EXPLANATION OF PLATE 31

Figs. 1, 2. *Lepidaspis serrata* gen. et sp. nov. 1, fused scale-units (NMC 19884),  $\times 2$ . 2, partly fused scale-units associated with lateral lamina (NMC 21472),  $\times 2$ .

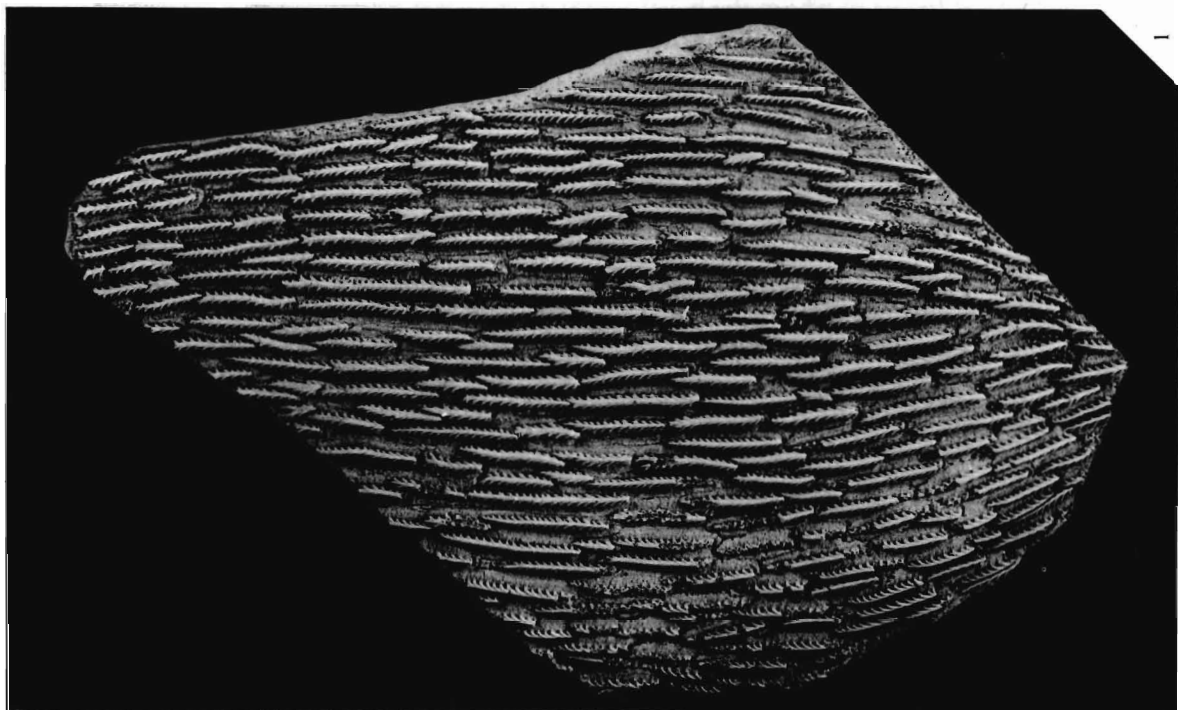
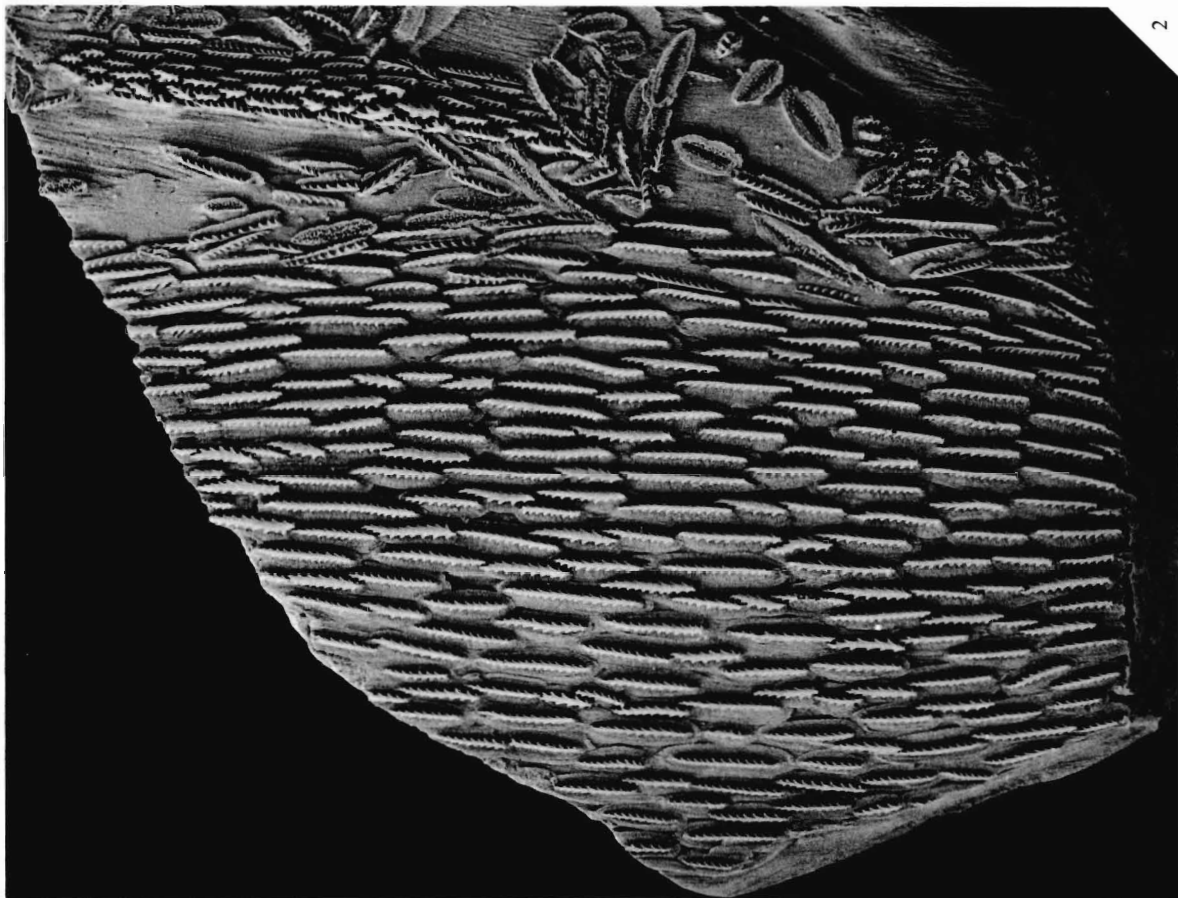

DINELEY and LOEFFLER, *Lepidaspis serrata*

branchial openings may reflect the paucity of complete specimens, but the absence of paired fins is not unexpected. The tail appears in NMC 19873 to have been heterocercal, but it is impossible to say whether the enlarged lobe was dorsal or ventral. The flattened cephalothorax and ventrally placed mouth suggest that *Lepidaspis serrata* was a bottom-feeder which may have scooped up bottom deposits with the aid of a protrusible oral cover. The abraded and secondary dentine ridges of the ventral surface suggest that there was continued wear on the belly, as a result of the benthonic mode of life.

Although the tail may have provided a means of propulsion during the early stages of development of an individual, the progressive fusion of compound scales to each other and the fusion of groups of caudal scale-units (Pl. 30) would have limited the flexibility in later stages. The active, immature, stages may have been followed by a sedentary life in maturity.

(c) *Growth*. There are several observations to explain in any hypothesis concerning growth in *L. serrata*:

1. In all of the better-preserved specimens, the anterior and lateral margins of the dorsal surface of the cephalothorax are thickened. In these areas, the basal parts form a continuous sheet and the barbed dentine ridges are more closely spaced than elsewhere on the cephalothorax.

2. Different specimens exhibit varying degrees of fusion of the basal plates of their scale-units on other regions of the body. In some individuals the basal plates are completely isolated, while in others they are entirely fused.

3. In specimens such as NMC 19874, the thickened lateral margins of the cephalothorax are preserved in association with a few isolated scale-units.

4. On the lateral margins of the cephalothorax of a few specimens and on the ventral surface of forms in which the basal plates of the scale-units are fused, broad, smooth ridges are interspersed with the more typical ridges. These broad ridges are commonly superimposed on abraded ridges.

The thickened margins of the cephalothorax and the armour around the orbits perhaps developed at an earlier stage of growth than that at which the basal plates of the rest of the scale-units fused. During the development of the individual, there was progressive fusion of the basal plates of the scale-units of the dorsal and ventral surfaces. On the cephalothorax, fusion began on the lateral margins of adjacent

---

#### EXPLANATION OF PLATE 32

- Figs. 1-3. *Lepidaspis serrata* gen. et sp. nov. 1, fragment of caudal region, showing longitudinal row of compound scales, together with caudal scale-units (NMC 19891, paratype),  $\times 2$  (see text-fig. 75). 2, reversed specimen showing lateral line canals as system of grooves on underside of basal plates of cephalothorax (NMC 21477),  $\times 0.8$  (see text-fig. 77A). 3, detail of grooves from fig. 2 (NMC 21477),  $\times 3$  (approx.).
- Figs. 4-8. *Lepidaspis serrata* gen. et sp. nov., scanning electron micrographs. 4, detail of surface pore of scale-unit,  $\times 560$  (approx.). 5, internal surface of scale-unit showing pores,  $\times 30$ . 6, external surface of scale-unit with abraded superficial ridge (same specimen as fig. 5),  $\times 30$ . 7, external surface of scale-unit,  $\times 30$ . 8, external surface of caudal scale-unit,  $\times 30$ .

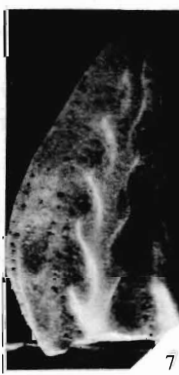
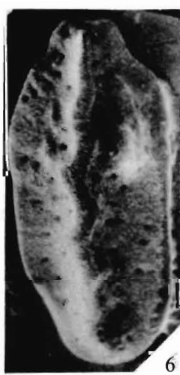

DINELEY and LOEFFLER, *Lepidaspis serrata*



scales and proceeded anteriorly and posteriorly; on the tail, the sutures between adjacent basal plates are overgrown by small tubercles.

The broad smooth ridges which are interspersed with, or overlie, abraded ridges, are undoubtedly of secondary origin. Their formation appears to have occurred only in areas where the basal plates of the underlying scale-units are fused. In two specimens (NMC 19878, 19879) secondary tubercles are common on the ventral, post-oral surface of the cephalothorax; they are also present on the lateral margins of the cephalothorax of NMC 19879. The ridges commonly associated with these secondary tubercles are mostly abraded, so it is assumed that the secondary dentine was produced in response to abrasion.

#### Affinities of *Lepidaspis serrata*

The laterally barbed dentine ridges of *L. serrata* are of a type common amongst the Agnatha. Short dentine ridges with anterior directed lateral processes occur within the Traquairaspididae, *Weigeltaspis* and the Psammosteididae; fragments have also been ascribed to *Lophosteus* Pander, *Orthaspis plana* Brotzen, and *Lophaspis crenulata* Brotzen. Gross (1947), however, discovered that *Lophosteus superbus* Pander was not an agnathan; later work (Gross 1969, 1971) showed it to be a teleostome. Together with *Andreolepis* Gross, *L. superbus* was placed in the family Lophosteidae, order Lophosteiformes Gross (1969). *L. mutabilis* Brotzen (1934) is, however, heterostracan and was believed by Gross (1947) to belong either to *O. plana* Brotzen or to *Strosipherus indentatus* Pander; there has since been some dispute concerning the systematic position of *L. mutabilis*. Tarlo (1964, 1965) placed it in the genus *Tesseraspis*, as *T. mutabilis*, which he considered to be synonymous with *Lophaspis crenulata* Brotzen; Ørvig (1969a) agreed with Gross (1961) in referring *Lophosteus mutabilis*, together with *Lophaspis crenulata* and *O. plana* Brotzen, to *Traquairaspis* sp.

Since barbed superficial ridges are known in the Teleostomi and the Heterostraci, it is not surprising that they also occur in the Osteostraci (Gross 1961, p. 125, fig. 18b).

Detached scales with a basal plate and a crown of one or more tubercles have recently been described from the Cape Phillips Formation of Cornwallis Island (Thorsteinsson 1973); although much smaller, they resemble the scale-like units of *Lepidaspis* in ornament and in the shape of the basal plate. These scales, which were named *Pilolepis margaritifera*, were said to belong to an 'early representative of, or to a predecessor of the early menaspoid bradyodonts' (ibid., p. 51) on account of the presence of a small asymmetric spine, with similar ornamentation to the scales. Because of these similarities, caution is needed in determining fragmentary material. In *L. serrata* there is wide variety of ornament on each individual and there is widespread development of secondary tubercles, which commonly differ in shape from the primary.

Material referred to *L. serrata* is characterized by the subdivision of the armour into scale-units. Specimens with slightly different ornamentation, and which are not

---

#### EXPLANATION OF PLATE 33

Figs. 1, 2. Cf. *Lepidaspis serrata* gen. et sp. nov. 1, Type 1, plate fragment (NMC 21521),  $\times 0.66$ . 2, Type 2, caudal fragment (NMC 21522),  $\times 0.8$ .

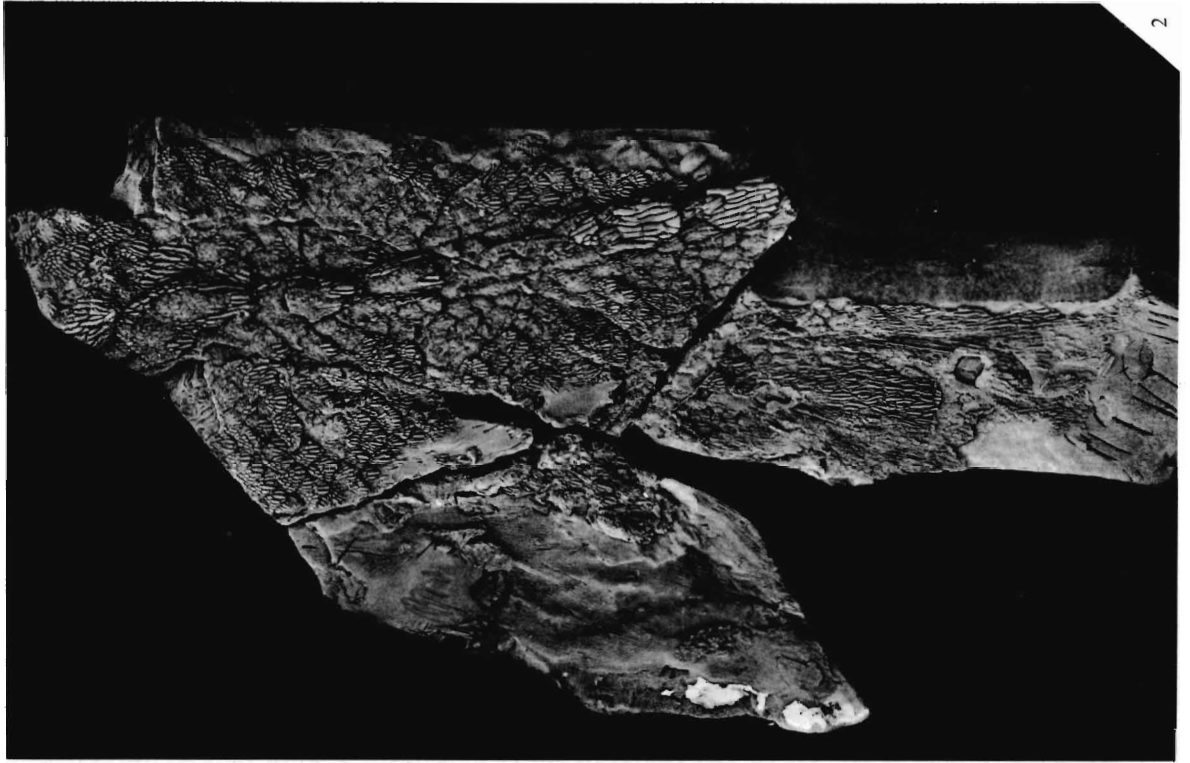

DINELEY and LOEFFLER, *Lepidaspis serrata*

subdivided into scale-units, are referred to cf. *L. serrata*. It is possible that some of these specimens are not close to *Lepidaspis*, but histological examination of this material is prevented by its opacity and extreme flattening.

Irrespective of the value of ornament in taxonomy, relationship to the Pteraspido-morphi is suggested by the absence of jaws, the shape of the body, and the anterior position of the orbits. Both of the orders included in this class, Heterostraci and Thelodontida, share with this material the lack of an ossified endocranium and the anterior position of the orbits; neither possesses a naso-hypophysial duct.

The shape of *L. serrata*, with wide flat cephalothorax and narrow tail, resembles that of several thelodont genera including *Logania* and *Turinia*. Although the scales of thelodonts may be locally differentiated, they are never fused as in *Lepidaspis*. There is also a resemblance between *Lepidaspis* and *Drepanaspis* in the shape and position of the mouth.

cf. *Lepidaspis serrata* gen. et sp. nov., Type 1

Plate 33, fig. 1

*Material.* NMC 21521, fragment of cephalothorax (Pl. 33); NMC 21519, part of the underside of NMC 21521, reversed on to 'Plasticraft'; NMC 21520, indeterminate fragment.

*Locality.* GSC 69014.

*Description.* NMC 21521 and NMC 21519 represent the greater part of the cephalothorax of an individual which must have been of the order of 200 mm long and 130 mm wide. The whole carapace appears to have been dorso-ventrally flattened, but it has not been possible to determine which was the dorsal surface. The surface exposed in NMC 21521 (Pl. 33) has a thickened lateral margin which, although incomplete, appears to have been convex. There is a great variety of ornamentation. On the lateral margins of the cephalothorax, long (5–8 mm), slender (0.5 mm), laterally barbed ridges are overgrown by rather bulbous tubercles, probably of secondary origin. In a 30–40 mm wide band, adjacent to the lateral margin, ornament is of wide (1 mm), barbed ridges and narrower (0.5 mm), interstitial barbed ridges; the narrow ridges are irregular or longitudinal rather than cyclomoriform, the wider ridges commonly being abraded. Toward the centre of the cephalothorax, the abraded barbed ridges become progressively wider and more leaf-shaped (Pl. 33); between adjacent ridges are large, flat-topped tubercles of irregular shape. Although the leaf-shaped ridges are commonly abraded, the irregular tubercles have smooth shiny surfaces and are typically subdivided into lobes by superficial grooves.

*Remarks.* These specimens resemble *L. serrata* but differ in being larger, having interstitial ridges, and medial ornamentation of irregularly shaped tubercles. There appear to be at least two generations of tubercles; medially, the abraded, leaf-shaped ridges are lower than the irregular tubercles. It can therefore be assumed that the irregular tubercles are secondary, as are the irregular, bulbous tubercles of the lateral margin.

cf. *Lepidaspis serrata* gen. et sp. nov., Type 2

Plate 33, fig. 2

*Material.* NMC 21522, ?tail fragment.

*Locality.* GSC 69014.

*Description.* This specimen comprises an assemblage, 120 mm long and 65 mm wide, of imbricated scales of two types (Pl. 33). Extending along the length of the fragment is a single row of seven ridge scales, each of which is about 15–20 mm long and about 10 mm wide and is arched about its long axis. On the more anterior ridge scales, ornament takes the form of longitudinal barbed ridges of various lengths; on the two posterior scales are broad, closely spaced, dentine ridges with weakly developed lateral serrations.

On either side of the row of ridge scales are imbricated, rhomboidal scales with an average diameter of 4 mm. Each has a superficial ornament of long and short, laterally barbed dentine ridges, the longer ridges commonly being more posteriorly placed. On the rhomboidal scales and the more anterior ridge scales, the lateral processes of the dentine ridges point forward and a system of crests is developed.

*Remarks.* This fragment apparently represents the caudal region of a large individual. The broad ornamentation of the posterior ridge scales suggests that the dentine is locally of secondary origin. The dentine ridges of the rest of the scales superficially resemble those of *L. serrata*, but the squamation is unlike that of the latter species. It is possible that this fragment may belong to the same type of animal as that referred to cf. *L. serrata*, Type 1.

## CONCLUSIONS

## OSTRACODERM BIOSTRATIGRAPHY

Previous attempts to correlate the horizons of European and North American ostracoderm faunas failed because it was assumed that ostracoderms had identical stratigraphic ranges in the two areas. For the reasons discussed in detail below (p. 201), the value of ostracoderms in correlating deposits on different Silurian continents is limited to those anaspids, thelodonts, and others which were able to migrate freely across ocean waters. Currently, therefore, the only reliable means of correlating the Silurian ostracoderm faunas of Europe with those of western and Arctic Canada is with the aid of associated invertebrates, graptolites, or conodonts. The value of ostracoderms for correlation of Silurian strata within each faunal province, however, remains.

Dineley (1967) has drawn attention to the similarity between the Late Downtonian and Early Dittonian ostracoderm faunas of Nova Scotia, Britain, and Vestspitsbergen. A close similarity between the Dittonian ostracoderm faunas of Vestspitsbergen and western Canada is also demonstrated (p. 205). The spread of the mixed, 'Atlantic', fauna, which is thought to have begun at the base of the zone of *Traquairaspis pococki*,

permits the reliable use of ostracoderms for correlation of Early Devonian strata in North America and Europe. Data from associated invertebrates and the stratigraphic position of the ostracoderm horizons are regarded at the moment as being more important than the (incompletely) known ranges of the ostracoderms in determining the ages of the western Canadian faunas.

During the present study, and prior to comparing Canadian and European ostracoderm faunas, the need to review the basis for correlation of the European and North American ostracoderm-bearing strata with the marine stages became apparent. This was necessary in the light of recent work on the local invertebrates and microfaunas and the revision of the Siluro-Devonian boundary.

Owing to the inherent difficulties of correlating marine and non-marine strata, no generally accepted intercontinental zonal scheme including both facies yet exists for the Late Silurian and Early Devonian. The use of ostracoderms in the Anglo-Welsh borders (White and Toombs 1948; White 1950a) has been extended to the correlation of strata in Artois (White 1956, 1960), Westphalia (Schmidt 1959), Podolia and Lithuania (Obruchev and Karatajute-Talimaa 1967, 1968), and eastern Canada and Vestspitsbergen (Dineley 1967). Unfortunately it is difficult to equate these zones with those of the marine facies, which are based on invertebrates.

A review and revision of correlation of all European ostracoderm-bearing strata, although necessary, is outside the scope of this work. Here, only those sections containing representatives of relevant groups (Traquairaspididae, Corvaspididae, Cyathaspididae, and Pteraspididae) are dealt with.

#### A. *Lithuania and Latvia*

Obruchev and Karatajute-Talimaa (1967) directly compared the Upper Silurian and Lower Devonian of the Polish-Lithuanian trough with that of the Anglo-Welsh borderlands. The Til'ze Suite, which contains *Corvaspis*, *Traquairaspis*, *Tesseraspis*, *Anglaspis*, and poraspidinids, was correlated by Obruchev and Karatajute-Talimaa (1967, 1968) with the *Traquairaspis* zones and referred to the Dittonian of Allen and Tarlo (1963); since 'Dittonian' is used here in the sense of White (1950a), the Til'ze Suite is correlated with the upper part of the Downtonian (text-fig. 78). Because the base of the Minija Beds has yielded *Monograptus formosus* and *Pristiograptus ultimus* (Obruchev and Karatajute-Talimaa 1967), a Pridolian age for both the Minija and the Jura Beds can be interpolated. The presence of *Belgicaspis crouchi* in the overlying Stroniskyai Suite, and *Rhinopteraspis dunensis* in the Sesuvi Formation, permits their correlation with the Dittonian and Breconian respectively.

#### B. *Estonian Saaremaa (Island of Oesel)*

The ostracoderm-bearing beds of Saaremaa were long referred to the Ludlovian (Denison 1964 and refs. therein), but in a new stratigraphic classification and revised correlations (Kaljo, cited in Mark-Kurik 1969) the Kaugatuma and Ohesaare Stages are allotted to the Downtonian; the Jaagarahu Stage and the lower part of the Rootsikula Stage are referred to the Wenlockian, and only the upper part of the Rootsikula Stage and the Paadla and Kuresaare Stages remain in Ludlovian (Mark-Kurik 1969, fig. 2). Mark-Kurik (1969) and Mark-Kurik and Noppel (1970) have described the distribution of ostracoderms in these stages.

The acanthodian and thelodont faunas led Karatajute-Talimaa (1968a) to suggest

	EUROPEAN STAGES	ANGLO WELSH CUVETTE (WHITE (1950))	"FISH" ZONES (WHITE (1950))	ANGLO WELSH CUVETTE (ALLEN & TARLO (1963))	VEST-SPITSBERGEN	PODOLIA	LITHUANIA & LATVIA	ESTONIAN SAAREMAA	BEYRICHIE-NKALK ERRATICS
LOWER DEVONIAN	EMSIAN	U			GREY HOEK FM (Part)				
		M							
	SIEGIANIAN	L	BRECONIAN		BRECONIAN	WOOD BAY FORMATION		SESUVI FORMATION	
		M		<i>R. dunensis</i>					
	GEDINNIAN	U	DITTONIAN	<i>A. leachi</i> <i>B. crouchi</i> <i>Pt. rostrata</i>	DITTONIAN	BEN NEVIS FORMATION	OLD RED GROUP	STONISKYAI SUITE	
		L		<i>Pt. leathensis</i>		FRAENKELRYGGEN FORMATION	CHORTKOV HORIZON		
			<i>T. symondsii</i> <i>T. pacocki</i>			BORSCHOV HORIZON	TIL'ZE SUITE	BEY. 36, 37	
UPPER SILURIAN	PRIDOLIAN	DOWNTONIAN		DOWNTONIAN	ANDREBREEN SST RED BAY CONGLOM.	SKALA HORIZON	JURA BEDS	OHESAARE K <sub>4</sub>	BEYS.
				<i>H. murchisoni</i>			MINIJA BEDS	KAUGATUMA K <sub>3b</sub>	
	LUDLOVIAN					PAGEGAI BEDS	KURESSAARE K <sub>3a</sub> PAADLA K <sub>2</sub> ROOTSIKÜLA K <sub>1</sub> (Part)		

TEXT-FIG. 78. Correlation of key European ostracoderm-bearing sequences.

that the Ohesaare Stage of Saaremaa is equivalent to the Minija Beds of Lithuania and Latvia, rather than to the Jura Beds as was proposed by Obruchev and Karatajute-Talimaa (1967); this modification was also used by Turner (1973). On the basis of ostracods (Kaljo and Sarv 1966; Abushik 1968), however, the Ohesaare Stage equates with the Jura Beds, as do discoveries of latest Pridolian or earliest Devonian conodonts in the middle fish horizon of the Ohesaare (Fahraeus 1969a and b). The lower part of the Ohesaare is probably equivalent to the upper part of the Minija Beds as well as to the Jura Beds; this is consistent with the faunal lists provided by Karatajute-Talimaa (1968b, table 2).

### C. *Beyrichienkalk*

Obruchev and Karatajute-Talimaa (1968) claimed that the erratic boulders of the Beyrichienkalk on the North German Plain supplement the section on Saaremaa, the upper part of which is missing. Fahraeus (1969a and b), while demonstrating that the conodont fauna of the Ohesaare Stage has a younger aspect than that of the Beyrichienkalk, admitted that he was referring to the ages of isolated faunas rather than to the units from which they were extracted. Turner (1973) suggests that thelodont assemblages of the erratic blocks range in age from Ludlovian to late Downtonian (*sensu* White 1950a).

### D. *Podolia (Ukraine)*

Here vertebrates occur in the Skala, Borshchov, and Chortkov Horizons and Old Red Group. Underlying the Borshchov Horizon, the Skala Horizon is regarded by Berry and Boucot (1970) as essentially equivalent to the Pridolian Stage, but by Cocks *et al.* (1971) as including strata of Ludlovian age; a single specimen of *Irregularaspis*,

which has not been figured or described, was reported by Obruchev and Karatajute-Talimaa (1967) from its uppermost beds. Only acanthodian spines have been found in the Borshchov Horizon, the lowest beds of which have yielded *Monograptus uniformis* (Koren 1967; Nikiforova *et al.* 1967) and *Icriodus woschmidti* (Mashkova 1967) and are therefore earliest Devonian. The succeeding Chortkov Horizon yields *Turinia*, *Apalolepis*, *Polymerolepis*, *Seretolepis*, *Corvaspis*, *Poraspis*, *Seretaspis*, *Irregularaspis*, *Ctenaspis*, *Pteraspis*, ?*Canadapterspis*, *Zascinaspis*, *Belgicaspis*, *Cephalaspis*, and ?*Traquairaspis*, and thus has a Dittonian aspect (*sensu* White 1950a). Identifications of *Traquairaspis* are perhaps suspect, as the figured material (Obruchev and Karatajute-Talimaa 1967, pl. 1, fig. 8) appears to be closer to *Weigeltaspis*. The Borshchov Horizon is presumably equivalent to the Devonian part.

#### E. Vestspitsbergen

On the accompanying chart correlation of the Vestspitsbergen sequence with the Lower Old Red Sandstone of the Anglo-Welsh area broadly follows Friend (1961), with the unit terms modified after Friend *et al.* (1966). Ørvig's studies lead to the view that the Fraenkelryggen Formation is equivalent to the *Phialaspis* and *Protopteraspis leathensis* zones only, the boundary between the Downtonian and Dittonian equivalents falling within or just above the *primaeva* Beds.

#### F. Gotland

Vertebrates in the Halle, Hemse, Eke, and Hamre Beds of Gotland are commonly osteostracans, anaspids, and thelodonts (see Mark-Kurik 1969 and refs. therein), but the cyathaspidid *Archegonaspis* is present in the Hemse Beds, the occurrence being dated as Early Ludlovian by the presence of *M. nilssoni* (see Denison 1956).

#### G. Vaygach Island, U.S.S.R.

*Archegonaspis bimarisi* Novitskaya (1970) from Vaygach Island was designated as ?Middle Ludlovian age on the basis of its 'primordial zone', which was supposed to indicate a 'higher level of evolutionary development' than European forms. In view of conclusions given above (p. 106), it is probable that the 'primordial zone' is merely a growth anomaly.

#### H. Timan, U.S.S.R.

The Eptarma Beds contain *Tolypelepis timanica* and *Traquairaspis* and may be of latest Silurian to earliest Devonian age. Obruchev and Karatajute-Talimaa (1968) correlated them with the latest Downtonian and earliest Dittonian (*sensu* Allen and Tarlo 1963).

#### I. The Urals

A fauna containing *Liliaspis* and *Pteraspis* sp., from the Polar region of the Urals was dated as Lower Devonian from the presence of *Pteraspis* by Novitskaya (1973).

#### J. Siberia

Krylova *et al.* (1967) regarded the Zubova Suite of the Tunguska syncline as of Gedinnian age; it has yielded *Steinaspis miroshnikovi*. The succeeding Kureika Suite, containing the bizarre and diverse amphiaspids, is considered (*ibid.*) to be Siegenian.

## NORTH AMERICAN CORRELATION

Recognition of the Pridolian Stage, and recent faunal studies, call for a revision of accepted correlations of the ostracoderm-bearing strata. Although particular attention is paid here to the northern and western Canadian faunas, an attempt to examine the basis of dating of all of the Silurian and Early Devonian ostracoderm faunas of North America is made. It is possible to provide precise dates for few of these faunas, and it is thought more useful to determine an accurate age bracket for a particular fauna, than to give a single but inaccurate and misleading date.

*A. Western and Arctic Canada*

Although ostracoderms have been known from the Late Devonian of Ellesmere Island since 1900 (Kiaer 1915), Silurian and Early Devonian forms were not reported elsewhere from western and Arctic Canada until 1955 (Thorsteinsson 1958). Since then, extensive geological exploration has led to the discovery of ostracoderm faunas in British Columbia, the Yukon, and the North West Territories. The ages of many of these faunas were estimated from the vertebrates alone. It now appears (Tarlo 1964; Broad 1968, 1971; Turner and Dixon 1971; Dineley 1973; Broad and Dineley 1973) that Arctic Canada was an evolutionary centre for certain groups of ostracoderms. The example has been given of a representative of the Traquairaspididae in the Cape Phillips Formation of Cornwallis Island, dated as Wenlockian on the basis of associated graptolites (Broad 1971). The association of *Corvaspis*, *Traquairaspis*, and *Anglaspis* is regarded as typical of the late Downtonian of Europe, but a similar association of traquairaspidids, cyathaspidids, *Anglaspis*, and *Corvaspis* has been recorded from transitional beds between the Allen Bay and Read Bay Formations on Prince of Wales Island (Turner and Dixon 1971); the invertebrate fauna of the upper 20 m of the transitional beds indicates a Late Wenlockian or Early Ludlovian age (Dixon *et al.* 1972).

It is concluded that the Silurian ostracoderm faunas of the North American and European regions were essentially separate, with limited interchange. When the two continents collided in the Early Devonian, a mixed fauna developed. The Devonian ostracoderm faunas of Europe and North America are similar and should be valuable for correlation between strata of both areas. The Silurian ostracoderm faunas of northern and western Canada can thus only be reliably dated by associated marine invertebrates.

*1. The Canadian Arctic islands*

(i) *Cornwallis Island*. Ostracoderms have been reported from the Cape Phillips, Read Bay, and Snowblind Bay Formations of Cornwallis Island (Thorsteinsson 1958, 1967; Thorsteinsson and Tozer 1963). In the Cape Phillips Formation, graptolites have been used to date five separate ostracoderm faunas ranging in age from Late Llandoveryan or Early Wenlockian to Early Ludlovian. The ostracoderms include forms similar to *Ptomaspis*, *Tolypelepis*, *Vernonaspis*, *Archegonaspis*, *Homalaspidella*, and *Traquairaspis* together with thelodonts and anaspids. A sixth fauna, from the Snowblind Bay Formation, comprising ctenaspids and ?*Anglaspis*, was dated as Early Devonian solely on the basis of the vertebrates (Thorsteinsson 1967). The preliminary note listing these faunas (Thorsteinsson 1967) included only tentative



identifications of the ostracoderms; no descriptions have yet followed. If the identifications are reliable, *Tolypelepis* and *Homalaspidella* appear earlier in Canada than in Europe, while *Archegonaspis* appears at approximately the same time. The association of *Homalaspidella*, *Ptomaspis*, and *Vernonaspis*-like forms in the Early Ludlovian part of the Cape Phillips Formation supports the conclusion that the estimated Downtonian age for the Beaver River fauna of south-eastern Yukon (Denison 1963, 1964) is probably too young (p. 197).

A dorsal shield, said to resemble a species of *Traquairaspis* from Somerset Island (Broad 1971) occurs in part of the Cape Phillips Formation of Cornwallis Island, which is dated as Late Wenlockian from associated graptolites (Thorsteinsson, cited in Broad 1971).

(ii) *Somerset and Prince of Wales Islands*. Ostracoderms were first reported from Somerset and Prince of Wales Islands in 1963 (Thorsteinsson and Tozer 1963). In a preliminary report concerning the fauna of the Peel Sound Formation (Thorsteinsson 1967), an Early Devonian age was deduced from the European ranges of the ostracoderms, which included new forms of traquairaspidids and corvaspidids and a new species of *Poraspis*. Ostracoderms have since been collected not only from the Peel Sound Formation of Somerset Island, Prince of Wales Island, and Boothia Peninsula, but also from the Read Bay Formation and from transitional beds between the Allen Bay and Read Bay Formations. Broad and Dineley have described much of the material from the Read Bay and Peel Sound Formations (Dineley 1968*a*, and in press; Broad 1968, 1971, 1973; Broad and Dineley 1973). Although the most complete section on Prince of Wales Island (including the upper 13 m of the Read Bay Formation and the lower 179 m of the lower member of the Peel Sound Formation) has yielded ostracoderms regarded as typical of the Late Downtonian and Dittonian of Europe, the invertebrate fauna indicates a Late Silurian age (Broad and Dineley 1973). The upper member of the Peel Sound Formation, which ranges in age from Siegenian to Eifelian, contains cephalaspidids, ctenaspidids, and pteraspidids (Broad 1971, p. 99).

Ostracoderms including *Thelodus*, *Logania*, traquairaspidids, cyathaspidids, *Anglaspis*, and *Corvaspis* have been reported from the transitional beds between the Allen Bay and Read Bay Formations on Prince of Wales Island (Turner and Dixon 1971). Although these beds were originally thought to be older (*ibid.*), the invertebrate fauna is Late Wenlockian to Early Ludlovian (Dixon *et al.* 1972). Large collections of well-preserved ostracoderms were recently made from equivalent strata on Somerset Island. Preliminary examination of the material indicates that both traquairaspidids and cyathaspidids are present, including forms similar to *Vernonaspis*, *Pionaspis*, *Ariaspis*, *Homalaspidella*, and *Traquairaspis angusta*.

(iii) *Ellesmere Island*. *Boothiaspis alata* Broad occurs in the Devon Island Formation in association with ostracoderms resembling *Corvaspis*, *Pionaspis*, and *Traquairaspis* (Broad 1973). Graptolites associated with the vertebrate-bearing stratum are thought to be of Pridolian age (*ibid.*, p. 37).

## 2. Western Canada

(i) *Beaver River (south-eastern Yukon)*. A fauna which includes *Vernonaspis*, *Ptomaspis*, *Dikenaspis*, *Ariaspis*, *Homalaspidella*, and *Traquairaspis* was described

in detail by Denison (1963) and was originally assigned an Early or Middle Ludlovian age on the basis of associated invertebrates. The vertebrate horizon is underlain by Early Wenlockian graptolites and overlain by *Monograptus dubius*. The presence of *Traquairaspis*, which was then regarded as restricted to the Downtonian and Early Dittonian, led Denison (1964) to suggest a Downtonian age for the fauna. Since *M. dubius* is now regarded as extending from the Llandoveryan to the Pridolian (Broad and Lenz 1972), and *Traquairaspis* has been recorded from the Wenlockian of Arctic Canada (Broad 1971), the age of the Beaver River fauna could lie anywhere within the range of Wenlockian to Pridolian. A Late Silurian age is suggested by the presence of *Conchidium* in the same beds as the ostracoderms (Hovedebo *et al.*, in Denison 1963).

(ii) *Snake River (northern Yukon)*. Ostracoderms from a locality on Snake River were identified by Denison (1964) as cf. *Dinaspidella* sp., *Poraspida* indet., *Cyathaspida* indet., and *Corvaspis*. Brachiopods and corals, probably of Late Silurian age, occur 12–15 m below the vertebrate horizon (Lenz, *cited in* Denison 1964), the Early Devonian age of which was inferred from the European ranges of the vertebrates (Denison 1964; Dineley 1965). *Dinaspidella* occurs in transitional facies between the Delorme and Road River Formations of the District of Mackenzie (p. 6). Its association with *Sigurdia* and *Poraspis* cf. *P. polaris* suggests that some Canadian occurrences of *Dinaspidella* correlate broadly with the Dittonian. The *Dinaspidella* from the Snake River fauna has been only tentatively identified from incomplete material; correlation of this fauna with either the Dittonian or the Delorme-Road River fauna would require more evidence.

From a locality 6 km due north of that described by Denison (1964) and Dineley (1965), Broad and Lenz (1972) reported *Vernonaspis major* Denison and *V. epitegosa* Broad. The succession at both localities is similar, ostracoderms occurring 15–20 m above the base of the Gossage Formation. Invertebrates associated with the two species of *Vernonaspis* are interpreted by Broad and Lenz (1972) as of Late Silurian or Early Devonian in age, Late Silurian being favoured in view of previous occurrences of *Vernonaspis*.

(iii) *Muncho Lake (British Columbia)*. North-west of Muncho Lake a fauna including *Listraspis*, *Pionaspis*, and *Traquairaspis* occurs in the Muncho-McConnell Formation (Taylor and MacKenzie 1970) 'several hundred feet' stratigraphically above Middle Silurian corals (Denison 1964). These particular cyathaspidids and the similarity of the traquairaspidid to *T. symondsi*, were thought by Denison (1964) to be Late Downtonian age. Since many species of traquairaspidids are now known (Broad 1971; this work) and the relative specialization of the cyathaspidids is open to debate, so precise an estimate must be treated with caution.

(iv) *Mount Sekwi (North West Territories)*. A new species, *V. sekwiae* (Denison 1964), from the lower of two ostracoderm-bearing horizons on Mount Sekwi, in the District of Mackenzie is associated with possibly Late Ludlovian corals and brachiopods (Lenz, *in* Denison 1964). The age of this horizon could, however, be Pridolian (Lenz 1974, pers. comm.). The higher horizon, containing *Anglaspis expatriata* Denison, was given as Late Downtonian on the basis of the similarity between *A. expatriata* and *A. macculloughi* (Denison 1964).

### 3. Eastern Canada

(i) *Nova Scotia*. The Knoydart Formation, which has yielded *Cephalaspis novascotiae*, *Traquairaspis symondsi*, *Canadapterspis whitei*, and *Belgicaspis crouchi*, resembles lithologically the Lower Old Red Sandstone of the Anglo-Welsh area (Dineley 1967, 1974). The replacement of the Upper Downtonian Zone fossil, *T. symondsi*, by small pteraspids occurs as at the Downtonian-Dittonian boundary in Europe (Dineley 1967).

(ii) *New Brunswick*: (a) *Jones Creek Formation*. The cyathaspidid in the Jones Creek Formation has been referred to *Cyathaspis* and compared to *C. banksi* from the Late Ludlovian and Early Downtonian of Britain (Denison 1964); Berry and Boucot (1970, p. 168) think the Jones Creek Formation is of Pridolian age.

(b) *The Dalhousie Formation*. The Dalhousie Formation has yielded a single pteraspid fragment (Dineley 1971) which suggests correlation with the Knoydart Formation of Nova Scotia. Berry and Boucot (1970) also regard this formation as of lowest Devonian age.

(c) *Atholville Beds*. The vertebrate fauna of the Atholville Beds of New Brunswick includes *Cephalaspis*, arthrodires, and acanthodians. Although these beds may possibly be late Early Devonian, Carroll *et al.* (1972) considered them to be more probably of Middle Devonian age.

### 4. United States

(i) *Wyoming and Utah*. Ostracoderms have long been known from the Beartooth Butte Formation of Wyoming (Bryant 1932, 1934, 1935; Denison 1964, 1967a, 1970) and the Water Canyon Formation of Utah (Denison 1952, 1953). *Allocryptaspis*, *Cardipeltis*, *Cephalaspis*, and *Protaspis* occur in both formations and their similarities extend to species level. Correlation of these faunas with the Late Dittonian of Europe is based on the presence of *Protaspis* and supported by associated arthrodires.

Ørvig (1961) described *Psephaspis*, a form subsequently referred to the Pteraspidae (Denison 1968), from a slightly higher horizon in the Water Canyon Formation. Denison (1970) questioningly referred this to the Early Devonian; other occurrences of the genus are Middle Devonian (Denison 1968).

(ii) *Ohio*. *Allocryptaspis* occurs together with *Zascinaspis* in the Holland Quarry Shale of Ohio. Denison (1964) regarded the Holland Quarry Shale as of Late Dittonian age, but as being slightly older than the Beartooth Butte and Water Canyon Formations, since the pteraspid which it contains 'could well be nearly and directly ancestral to' *Protaspis* (Denison 1960, p. 608). Correlation of the Holland Quarry Shale with the Siegenian is supported by stratigraphical evidence (Carmen 1960, cited in Denison 1960, p. 609).

(iii) *North-eastern U.S.A.* A number of formations, largely red-beds, in north-eastern U.S.A. (Vernon Shale, High Falls Formation, Longwood Shale, Shawangunk Formation, Bloomsburg Formation, and Wills Creek Formation) contain the cyathaspidids *Vernonaspis* and *Americaspis*. Denison (1964) viewed these faunas as being of Ludlovian age, but his Ludlovian included the Pridoli Stage. Most of these formations have few invertebrate fossils and their ages are determined only by stratigraphic position. Berry and Boucot (1970) place them all within the upper part of the Ludlow and the lower part of the Pridoli Stages.

## OSTRACODERMS AND BOUNDARIES

The Siluro-Devonian Boundary Commission of the International Commission on Stratigraphy has redefined the Siluro-Devonian boundary (McLaren 1973) as being at the base of the zone of *Monograptus uniformis*, which coincides with the boundary between the Lochkovian and the Pridolian Stages in the Barrandian region of Czechoslovakia. In the type section at Klonk, marine carbonates predominate (Chlupáč *et al.* 1972). Since vertebrates are extremely rare in this section and do not include ostracoderms, the problem of relating the Downtonian and Dittonian fish zones to the marine succession remains.

The onset of the Old Red Sandstone deposition in the classical section of the Ludlow area may correspond with the base of the Pridoli Formation in the Barrandian area. Martinsson (1967) and Shaw (1969) explain this correlation on the basis of links between the ostracod and graptolite sequences. When proposing the positioning of the Siluro-Devonian boundary at the top of the Pridoli, Bouček *et al.* (1966) regarded the latter boundary as corresponding to the Downtonian-Dittonian boundary of Allen and Tarlo (1963), that is, at the change from estuarine to fluvial conditions at the base of the 'Psammosteus' Limestones Group, where the appearance of *Traquairaspis* was supposed to follow a major faunal break.

Allen and Tarlo's (1963) Downtonian-Dittonian boundary is accepted by a number of geologists including Jaeger (1964), Abushik (1967), Obruchev and Karatajute-Talimaa (1967), Martinsson (1969), Cocks *et al.* (1971), and Turner (1973), as the closest possible approximation to the base of the zone of *M. uniformis*. Tarlo (1964) believed that the same boundary, marked by the incoming of *Traquairaspis*, was recognizable in Nova Scotia, Podolia, and Vestspitsbergen. Westoll *et al.* (1971) have, however, questioned the value of *Traquairaspis* in marking such a boundary, suggesting that *Traquairaspis* might occur below what was then its known range. Indeed, Squirrell and Downing (1969) had already reported *T. pococki* from well below the 'Psammosteus' Limestones, and Broad (1971) has reported traquairaspidids from the Wenlockian of Canada. Thus the first appearance of *Traquairaspis* is of no real value for the definition of either the Siluro-Devonian boundary or the base of the Downtonian.

*Traquairaspis* was present in Arctic Canada throughout the Late Silurian, and its sudden appearance in the Downtonian of Europe was a result of the collision of the North American and European continents and of the spread of Old Red Sandstone facies. There is as yet no reason to suppose that this event coincided precisely with the first appearance of *M. uniformis* in the marine facies.

Turner (1973) correlated the base of the (thelodont) zone of *Turinia pagei* with the base of the zone of *M. uniformis*, on the assumed equivalence of the latter with the base of the *Traquairaspis* zones of the Anglo-Welsh borders. Turner's work merely demonstrates that the change in the thelodont faunas coincided with the first widespread appearance of *Traquairaspis* in Europe (excluding Scotland); such a change is predictable in terms of a model involving continental collision.

Other views on the equivalent to the revised Siluro-Devonian boundary in the non-marine facies are equally poorly substantiated. Berry and Boucot correlated the Skala Horizon of Czechoslovakia, which they regarded as essentially corresponding

to the Pridolian Stage, with the lower part of the British Downtonian 'including the zone of *Hemicyclaspis* and possibly part of the overlying zone of *Traquairaspis*' (1970, p. 18). Precisely why part of the overlying zone of *Traquairaspis* was included in this correlation is not apparent; Boucot and Pankiwsky (1962, p. 7) had earlier claimed that the Skala Horizon 'certainly antedates the Upper Downtonian zone of *Traquairaspis* and includes the Ludlow Bone Bed plus at least a portion of the Lower Downtonian zone of *Hemicyclaspis*'. Accepting Berry and Boucot's (1970) proposed equivalence of the Skala Horizon, Broad and Dineley (1973) provided a tentative correlation of White's (1950a) fish zones with the marine and non-marine stages; they placed the Siluro-Devonian boundary within the lower part of the *Traquairaspis* zones. Cocks *et al.* (1971) regard part of the Skala Horizon as being older than Pridolian.

During the debate about the Siluro-Devonian and the Downtonian-Dittonian boundaries, confusion concerning the ranges of certain ostracoderms has arisen. Since 1963 Tarlo has given the ranges of ostracoderms in terms of his revised Downtonian-Dittonian boundary. Denison (1964) regarded the Downtonian (*sensu* White 1950a), Early and Middle Dittonian stages as corresponding exactly to the Gedinnian, i.e. Early Devonian in age.

Clearly, until it is possible to correlate precisely between the marine and the non-marine stages, it is unwise to present the ranges of ostracoderms in terms of the marine stages unless they can be dated with associated marine fossils. The Canadian ostracoderm faunas are of particular value in this respect; graptolites and conodonts occur in association with some of the ostracoderm faunas from the Mackenzie Mountains (D. Perry, pers. comm.) and brachiopods can also be used for dating (Gabrielse *et al.* 1973). It may eventually be possible to date some of the faunas described in this work directly relative to a graptolite zonal framework.

For present purposes, the position of the Siluro-Devonian boundary in the non-marine facies is arbitrarily accepted as that proposed by Tarlo (1964), i.e. at the base of the *Traquairaspis* zones of the Anglo-Welsh area. The Downtonian-Dittonian boundary is retained in the form proposed by White (1950a). The latter boundary, marked by the broad replacement of *Traquairaspis* zones by pteraspids, is of proven value for correlation throughout Europe, Vestspitsbergen, and eastern Canada (Dineley 1967). Although the same faunal succession has now been found in western and Arctic Canada (Broad 1971; Broad, Dineley, and Miall 1968), it remains to be seen whether the replacement of *Traquairaspis* by pteraspids is as sharp as in Europe. Indications from the Peel Sound Formation of the Arctic islands are that a similarly sharp faunal change occurs.

The assumption above that the introduction of *Traquairaspis* and *Turinia pagei* into the Anglo-Welsh borders does broadly coincide with the base of the zone of *M. uniformis* should be tested by the precise dating of ostracoderm faunas by independent means. This is made difficult by the fact that the marine and the Old Red Sandstone facies generally lack suitable fossils in common. However, the occurrence in the District of Mackenzie of a typical Dittonian ostracoderm fauna in deposits with ostracods and rare marine invertebrates, in a section containing datable brachiopod faunas (Section 43, Gabrielse *et al.* 1973), suggests that it might be possible to correlate between the ostracoderm zonation of the non-marine suite and the invertebrate

zonation of the marine facies. Indeed, the brachiopod faunas of that particular section permit dating of the ostracoderm fauna as Early Devonian.

To achieve such correlation, it would be necessary to date accurately a number of similar occurrences. It is hoped that this description of ostracoderm faunas from various localities within the District of Mackenzie will eventually aid such a study. Even if it becomes possible to date the range of ostracoderm species in this way, it is unlikely that the advent of the mixed 'Atlantic' ostracoderm fauna will be of much value for correlation, because it is inhibited by a facies change which is undoubtedly to some extent diachronous.

The Downtonian-Dittonian boundary should be maintained at the position proposed by White (1950a), i.e. where *Traquairaspis* is replaced by pteraspids. This faunal change is independent of facies and appears to have affected the whole 'Atlantic' faunal province; it is seen in Britain, North-west Europe, Vestspitsbergen, and eastern Canada. It can also be recognized in broad terms in western and Arctic Canada. Consequently, the first appearance of the pteraspids is of greater value than the first appearance of *Traquairaspis* for wider correlation.

The provinciality of Lower Devonian ostracoderm faunas renders it unlikely that a system of zonation involving Heterostraci and Osteostraci will be extended beyond the Lower Devonian Old Red Sandstone continent. Turner's (1973) report of *Turinia pagei* from Australia suggests that thelodonts might ultimately be useful in worldwide correlation of Devonian non-marine strata. A postulated marine (larval) stage apparently freed them from the constraints imposed upon the Osteostraci and Heterostraci by ocean barriers.

#### DISTRIBUTION OF THE OSTRACODERMS

It is now apparent that, throughout the Silurian and possibly also the Ordovician, the ostracoderm faunas of northern and western Canada differed from those of Europe, but that by the Early Devonian, there were strong faunal affinities between the two areas. The most significant differences were in the distribution of the Heterostraci and the Osteostraci. During the Silurian, Osteostraci were common and diverse in Europe and Heterostraci rare. In northern and western Canada, the reverse applied; Osteostraci were rare and Heterostraci common and diverse. The influx of Heterostraci to the European area occurred late in the Downtonian; although marked throughout Europe by the initial abundance of *Traquairaspis*, it was accompanied by the introduction of *Corvaspis* and of other Heterostraci.

At or about the same time there was, seemingly, a migration of Osteostraci into North America. Although *Hemicyclaspis* is present low in the Peel Sound Formation of Somerset Island, Osteostraci are abundant only at higher levels; in faunas from the Mackenzie Mountains, osteostracans are present only in the Devonian.

It is possible to explain the distribution of ostracoderms during Late Silurian and Early Devonian time in terms of a plate tectonic model, in which northern and western Canada and Europe were situated on different plates; faunal exchange between the two continents was limited prior to their collision. McKerrow and Ziegler (1972) reconstructed the distribution of Silurian continents by regarding the position of ancient oceans as recognizable on the basis of a number of stated criteria.

The relative positions of the continents were based partly on the palaeomagnetic maps of Smith *et al.* (1973), but included a number of modifications. In addition to the three adjacent continents, there was also an Asian continent (Siberian Platform of McKerrow and Ziegler 1972). It included Asia east of the Urals and north of the Himalayas and would have lain on the opposite face of the globe. A scrutiny of ostracoderm distribution in terms of these continents suggests that each was part of a separate faunal province, with limited interchange of certain groups.

Ordovician vertebrates are too rare to be of independent value in assessing the distribution of ostracoderms, but they tend to confirm the provinciality of Silurian distribution. North American Heterostraci are known in the Middle Ordovician of western U.S.A. (Denison 1956, 1967*b*, and refs. therein) and Quebec (Eliuk 1973). Ostracoderms have also been found in the Ordovician of Australia (A. Ritchie, pers. comm.) but their affinities are uncertain, as are those of *Archodus* and *Palaeodus* from the Ordovician of the U.S.S.R. (Rohon 1889).

The distribution of the major Silurian ostracoderm groups is discussed below:

1. *Heterostraci*. The Traquairaspididae appeared in the tropical regions of the North American continent (the present-day Arctic) in the Wenlockian and were joined in the Ludlovian by the Corvaspididae; both families remained confined to this continent until the late Downtonian. The Cyathaspididae, too, are known from the Wenlockian of Arctic Canada, but were more numerous and diverse in the Late Silurian; only three cyathaspidid genera are known from the same time interval in Europe. Heterostraci appear to have been present in Gondwanaland and the Asian (Siberian) continent in the Silurian; undescribed Heterostraci have been reported from Algeria (Mutvei 1956) and Heterostraci of uncertain affinities have been reported from Siberia (Bystrow 1959) and China (P'an 1961).

2. *Osteostraci*. Undisputed Osteostraci were present around the European continent in the Middle Silurian and became numerous and diverse in the Late Silurian. From the same time interval in the North American continent, only two genera of osteostracans have been reported (*Ateleaspis* from Scotland and *Hemicyclaspis* from Scotland and Arctic Canada). Osteostraci are not known from Gondwanaland or the Asian continent in the Silurian.

3. *Thelodontida*. Turner (1973) recognized three Silurian thelodont faunal provinces. Her *Thelodus parvidens* fauna, which occurred in the Anglo-Welsh borders, Nova Scotia, and New Brunswick, may have been restricted to this 'peninsula' of the European continent. Her *Logania* fauna occurs in Scotland, Norway, and Siberia, and it is difficult to see how these areas were linked, unless the thelodonts involved were able to migrate across the ocean-deep waters between the North American, European, and Asian continents. Similarly, the *T. schmidtii-laervis* fauna of Turner (1973) is present in the Canadian Arctic region of the North American continent and in the Baltic and southern Scandinavian region of the European continent. Turner suggested that exchange between the Baltic and Canadian regions may have been by a route which bypassed Scotland and the eastern Canadian-Anglo-Welsh area; perhaps latitude, possibly influencing climate, had a stricter control on the distribution of Silurian thelodonts than did ocean barriers.

4. *Anaspida*. The pattern of distribution of the anaspids suggested to Halstead and Turner (1973) a flourishing Silurian population inhabiting a single faunal province, embracing Arctic Canada, Scotland, Norway, and the Baltic. Since this is similar to the distribution of the Baltic thelodont fauna recognized by Turner (1973), it seems that restrictions on migration were comparable. The fact that these areas were all of similar palaeolatitudes implies that climatic control may have been important.

Although the earliest anaspids are known from marine strata (Thorsteinsson 1967), Denison (1966) regarded later occurrences as non-marine; a marine larval stage may have been involved in their dispersal.

The distribution of ostracoderms in terms of the four Silurian continents has the following pattern:

1. North America. The ostracoderm fauna includes anaspids and thelodonts but is particularly characterized by the rarity of the Osteostraci and the abundance and diversity of the Heterostraci. The Traquairaspididae, Corvaspididae, and Poraspidinae were restricted to this continent in the Silurian.
2. Europe. The ostracoderm fauna includes anaspids and thelodonts but is particularly characterized by the rarity of the Heterostraci and the abundance and diversity of the Osteostraci.
3. Gondwanaland. The ostracoderm fauna is poorly known, but appears to have included only Heterostraci.
4. Asia. The ostracoderm fauna is little known, but Heterostraci and Thelodontida seem to have been present.

The European and North American continents can justifiably be said to have been parts of two separate faunal provinces; their ostracoderm faunas are distinct and appear to have evolved independently, although there was interchange of certain groups. The ostracoderm faunas of the Asian and Gondwanaland continents are too inadequately known to determine their affinities with the European and North American faunal provinces or with each other.

Invertebrate faunas displayed similar provinciality in the Lower Palaeozoic; Williams (1969) recognized three brachiopod faunal provinces in Britain in the Ordovician. His American and European provinces broadly equate with the North American and European ostracoderm provinces of the Silurian, and his Baltic province with that recognized by Turner (1973) on the basis of thelodonts. The brachiopod faunal provinces became indistinguishable in the Late Ordovician, presumably because Iapetus had narrowed or shallowed sufficiently to be no longer a barrier to the migration of these organisms. Distribution of the major groups of ostracoderms suggests that Iapetus continued to inhibit thelodont migration until the Mid-Downtonian, and the migration of most Osteostraci and Heterostraci until the Late Downtonian.

Highland Scotland occupies a problematic position in such a scheme; although it was supposedly part of the North American plate, its ostracoderm fauna included Osteostraci, anaspids, thelodonts, and Heterostraci at various times in the Silurian. The presence of Osteostraci in Scotland may be explained in terms of rare species



being able to migrate across the ocean barrier or by ephemeral land connections between Scotland and the European continent.

In the Late Downtonian a mixed hererostracan-osteostracan fauna became widespread throughout the adjoined North American and European continents, separate North American, Baltic, and European faunas no longer being recognizable. At the same time, a distinct ostracoderm fauna arose in the Siberian region of the Asian continent; no osteostracan or heterostracan genera common to both the Asian and the European-North American region have been found. Only the ubiquitous *Turinia pagei* thelodont fauna is known from Gondwanaland in the Early Devonian. Early Devonian ostracoderm distribution may be outlined as follows:

1. *Heterostraci*. Traquairaspidids and corvaspidids were present in the North American and European regions in the Early Devonian; either or both are known from Nova Scotia, the Anglo-Welsh borders, Podolia, Timan, and the Baltic, on the former European continent and Vestspitsbergen on the former North American continent. The cyathaspidids, represented by the poraspidinids, irregulareaspidinids, and ctenaspidinids, are known from the Early Devonian of Canada, Vestspitsbergen, Podolia, and the Anglo-Welsh borders. A number of new groups, including the Pteraspididae, appeared and became ubiquitous throughout Europe and North America.

Heterostraci became well-established in Asia during the Early Devonian. Their remarkable radiation in the Siberian region during Siegenian and Emsian times produced the bizarre amphiaspids. The earlier, presumed ancestral Siberian heterostracans have been referred to the Ctenaspididae (Obruchev 1964), but they are not close to European and American representatives of that subfamily. Amphiaspids are not known outside Siberia; although Broad (1973) considered the Canadian *Boothiaspis* to be an amphiaspid, there appear to be no critical reasons for excluding it from the Cyathaspididae.

Heterostraci are not known in the Early Devonian of Gondwanaland.

2. *Osteostraci*. Largely in the form of *Cephalaspis*, Osteostraci became widespread throughout Europe and North America in the Early Devonian; they occur in Vestspitsbergen, Arctic and western Canada, western U.S.A., Britain, eastern Canada, Podolia, Timan, and the Baltic. Osteostraci have also been found in Asia (the Tuva region), but they are aberrant forms of uncertain affinity.

3. *Thelodontida*. The complex pattern of Silurian faunal provinces broke down in the Mid-Pridolian and was replaced by a fauna which was adapted to estuarine or delta-front conditions (Turner 1973); the latter fauna occurs in the Anglo-Welsh borders, Lithuania, Timan, and Germany (erratics). In the Devonian, this was replaced by a freshwater assemblage which has been found in Europe, Vestspitsbergen, Canada, and Australia (Turner 1973). Turner (1973) explains this wide geographical range in terms of a marine larval stage.

4. *Anaspida*. Early Devonian anaspids are too rare to be of significance in this study. Fragments have been found in the Early Devonian of Scotland and the Late Devonian of eastern Canada.

The 'Atlantic' fauna did not remain homogeneous throughout the province during the Early Devonian, and it is probable that local events and conditions resulted in the

development of subprovinces; these appear to have developed in Vestspitsbergen and in western U.S.A. during the Siegenian and Emsian (Dineley 1973).

Merging of the separate Baltic, North American, and European ostracoderm provinces occurred in the Late Downtonian. The 'Atlantic' faunal province was heralded by the first appearance of *Traquairaspis* in Europe and the major influx of Osteostraci into North America.

Although Heterostraci and Osteostraci were present in Asia in the Early Devonian, their evolution appears to have proceeded separately and divergently from that of the same groups in the 'Atlantic' province. Although little is known of the Asian faunas, it is probable that the continent included several faunal provinces, with little intercommunication. The amphiaspids are endemic to the Tunguska region of Siberia, which is regarded by Dineley (1973) and Halstead and Turner (1973) as a distinct faunal province. Osteostraci occur only in central Asia and the strange galeaspids are known only from the Yunan region of China. These faunas are too poorly known for their affinities with the 'Atlantic' or the Siberian provinces or with each other to be recognized.

A model involving continental collision also serves to explain two important observations:

1. The large influx of Heterostraci at the base of the zone of *Traquairaspis pococki* in the Anglo-Welsh area is relatively sudden and coincides with the change to predominantly fluvial conditions.
2. The appearance of ostracoderms in the Early Devonian of Podolia coincides with the beginning of Old Red Sandstone sedimentation at the base of the Chortkov Horizon; the exact equivalent of the base of the zone of *T. pococki* lies within the marine Borshchov Horizon, which contains only acanthodians.

It is evident from these that the spread of the 'Atlantic' fauna was related, at least in part, to the growing extent of Old Red Sandstone facies and not merely to the proximity of the North American continent.

Orogenies caused by continental collision result in the formation of red beds in environments ranging from terrestrial to fluvial and even to marine. Although few North American heterostracan faunas can be accurately dated, it is apparent that, at least in eastern U.S.A., ostracoderms were entering brackish, fresh water, and even hypersaline environments in the Late Silurian. The sudden increase of Heterostraci in Europe, at the base of the zone of *T. pococki*, might indicate that North American ostracoderm faunas became completely adapted to fresh and brackish water environments by that time, and that they were able to reach Europe once such environments had developed between the two continents.

#### THE HABITAT OF THE OSTRACODERMS

Denison (1956) disagreed with Romer and Grove (1935) in claiming that vertebrates were originally marine forms which subsequently entered fresh water; additional support for Denison has recently been provided by Lehtola (*cited in* Holman 1974). Denison (1956) considered that, in the Silurian, the Cyathaspididae and 'typical' thelodonts lived in the sea, while the Osteostraci and Anaspida were established in

brackish waters. A few cyathaspidids had invaded brackish or fresh waters by the Late Silurian, and by the Early Devonian fresh waters had acquired an endemic vertebrate fauna. The Osteostraci and Anaspida were then almost exclusively fresh-water inhabitants, but most Heterostraci were euryhaline forms capable of living in the sea or in the lower reaches of streams.

New discoveries result in only slight modifications to Denison's (1956) conclusions. The changing pattern of ostracoderm habitats during the Ordovician, Silurian, and Early Devonian can be summarized as follows:

*Ordovician.* Heterostraci appear to have occupied marine environments; no undisputed Osteostraci are known from this period.

*Silurian.* No ostracoderms are known from reliably dated Early Silurian deposits, and Middle Silurian ostracoderms are rare. Middle Silurian Heterostraci were marine and the Osteostraci were inhabitants of brackish lagoons (Denison 1956). Anaspids may have been euryhaline during the Middle Silurian; articulated specimens are known from marine (Thorsteinsson 1967) and brackish water (Denison 1956) deposits. In the Late Silurian, anaspids and osteostracans (excluding *Sclerodus*) were adapted to brackish and freshwater environments. The heterostracans occupied marine environments in the early Late Silurian, but had begun to enter brackish and fresh waters by the end of the period.

*Devonian.* The Osteostraci and Anaspida were now almost exclusively fresh water; the Heterostraci were considered by Denison (1956) to be euryhaline types, capable of living in the sea or in the lower reaches of streams. Devonian ostracoderms typically occur in Old Red Sandstone facies deposited under fluvial or brackish conditions.

An understanding of the environment in which the ostracoderms lived must be based in part on the mode of preservation of the fossils themselves, the associated invertebrates and the lithological character of the matrix. It is not known whether the ostracoderms at many of the localities described in this paper were biocoenose or were introduced by post-mortem transportation. At localities from which only a few specimens were collected there is no information concerning the abundance of the ostracoderms or the associated invertebrate fauna. Only at GSC localities 69014, 69017, 81050-81051, and at CS locality YB1, are ostracoderms sufficiently numerous and well preserved to have lived at or near the site of deposition. Common, well-preserved, and articulated remains, indicative of little or no post-mortem transportation, are present only at GSC locality 69014, and the environment of deposition seems to be that in which the animals lived (p. 5).

Ostracoderm armour from western North America is thin in comparison with that of its European counterparts (Dineley 1965), as is indicated by material from the Mackenzie Mountains.

	Mackenzie Mountains	Downtonian and Dittonian of Welsh Borders
Random samples of:	(mm)	(mm)
Cyathaspididae	0.3	0.6-1.0
Corvaspididae	0.5	1.75-2.0
Pteraspidae	0.6-1.0	1.0-2.0
Traquairaspididae	0.5	1.0-1.5

Comparison of British and Canadian material in thin section reveals crushing of the cancellous layer of the dermal bone in Canadian samples. In British material the chambers of the cancellous layer are intact and typically filled with crystalline calcite. The calcite infillings are probably due to early mineralization, and were responsible for preventing collapse of the bone during compaction of the sediment.

Since the same groups of ostracoderms are being compared in the two areas, it seems probable that the differences in preservation stem from differences in the diagenetic environment, rather than from inherent differences in the bone. It is undoubtedly significant that the uncrushed, calcite-filled bone is found in typical Old Red Sandstone clastic rocks, while the thinner, crushed bone occurs in carbonates and shaly dolomites which are commonly slightly bituminous.

The chemical environment of the surrounding sediment may have been less important in influencing the mode of preservation than the internal chemical environment produced by the gradual decomposition of the organic component of the bone and enclosed soft tissues. Decomposition of the organic matter under oxidizing conditions in a porous sediment may have produced physical conditions (Eh, pH) which were conducive to deposition of calcite in the cancellae; less well-aerated or reducing conditions, in the presence of pore waters of different composition, may have inhibited calcite deposition. In this context it is also of interest that the colour of the bone differs in the western Canadian and the British material; in the ostracoderms from the Mackenzie Mountains, the bone is typically black or dark brown but, in the British ostracoderms, white and pink coloration is more common. The dark colour of the Canadian bone is additional support for the suggestion that organic decomposition took place under mildly reducing conditions, the black coloration being imparted by carbonized material. However, ostracoderm remains preserved in the red, sandy Peel Sound Formation of Somerset and Prince of Wales Islands is closer in colour, though not in thickness, to bone from the Welsh borders.

Articulated ostracoderms are rare, remains being typically dissociated head-shields, bone fragments, and scales which may be sorted according to size and shape. Under oxidizing conditions, intact skeletons will rarely result. Not only does the corpse tend to be buoyed to the surface by gas building up in the body cavity but also, when the body eventually sinks, scavengers, wave action, and currents tend to disintegrate it completely (Schaefer 1972).

The black matrix and the presence of pyrite at GSC locality 69014, the only locality where articulated ostracoderms are preserved in quantity, indicate reducing conditions. Many bacteria cannot survive under reducing conditions and, as deposition was probably slow, they failed to produce sufficient gas to rupture, lift, or float the corpses. Physical disturbance was probably minimal, and the undisturbed lamination of the sediment also indicates the absence of benthonic scavengers and burrowers in what was probably a lagoon or bayou.

A major problem lies also in the interpretation of dolomitic lithologies. Dolomites can be primary or secondary and can form under various conditions; virtually any calcium carbonate rock can be dolomitized. It is at the moment difficult to provide an interpretation of the original environment of deposition unless dolomitization is

incomplete. Where it is complete, it can only be concluded that the fine grain size of the dolomite results from penecontemporaneous dolomitization of a micrite mudstone.

*Acknowledgements.* The writers record their gratitude to all who were instrumental in putting together this collection of vertebrates, who provided information, and who helped during the preparation of this paper.

The generosity of officers of the Geological Survey of Canada first gave D. L. D. the chance to examine, and later collect, material from the Delorme Formation. In particular Drs. H. Gabrielse and S. Blusson were most kind in arranging field support. Richard Farley was an enthusiastic and efficient field assistant. Dr. D. W. Organ, of the Chevron Standard Oil Co., Calgary, and Dr. A. C. Lenz readily supplied field data and specimens from the Sekwi Mountain area. The Natural Environment Research Council provided a Studentship for E. J. L. Professor T. S. Westoll, F.R.S., Dr. H. P. Whiting, and Dr. D. A. Russell have offered encouragement, help, and useful criticism throughout. Dr. S. C. Matthews and Professor J. W. Murray helped with taxonomy and electron-scanning photo-micrography. Robin Godwin carried out the photography, and Mrs. J. D. Rowland typed the text. Grants from the University of Bristol Publications Fund and the Royal Society towards the cost of this paper are gratefully acknowledged.

#### REFERENCES

- ABUSHIK, A. F. 1967. The importance of Ostracoda in drawing the Siluro-Devonian boundary in the European part of the U.S.S.R. *Int. Symposium on the Devonian System*, 2, Calgary 1967, 875-884.
- 1968. On the correlation of the Silurian deposits of Podolia, Soviet Baltic Region and Gotland (Data on ostracod investigation). In *Stratigraphy of the Baltic Lower Palaeozoic and its correlation with other areas*, 304-306, Vilnius. [Russian with English summary.]
- AFFLECK, R. J. 1950. Some points in function, development and evolution of the tail in fishes. *Proc. zool. Soc. Lond.* **120**, 349-369.
- ALLEN, J. R. L. and TARLO, L. B. 1963. The Downtonian and Dittonian facies of the Welsh Borderland. *Geol. Mag.* **100**, 129-155.
- — and TURNER, S. 1968. Dittonian Ostracoderm fauna from the Brownstones of Wilderness Quarry, Mitcheldean, Gloucestershire. *Proc. geol. Soc.* **1649**, 141-153.
- BALABAY, P. P. 1956. On the phylogeny of the Agnatha. *Zool. Zhur.* **35**, 874-890. [Russian with English abstract.]
- 1959. On the study of Pteraspidae from the Lower Devonian of Podolia. Communication I. *Nauk. Zap. l'viv. nauk. prirod. Muz.* **7**, 3-21. [In Russian.]
- 1960. On the study of Pteraspidae from the Lower Devonian of Podolia. Communication II. *Ibid.* **8**, 124-133. [In Russian.]
- BALL, H. W. and DINELEY, D. L. 1961. The Old Red Sandstone of Brown Clee Hill and the adjacent area. I. Stratigraphy. *Bull. Br. Mus. nat. Hist. (Geol.)*, **5**, 176-242.
- BERG, L. S. 1940. Classification of fishes, both Recent and fossil. *Trudy zool. Inst., Leningr.* **5**, 1-517. [In Russian.]
- BERRY, W. B. N. and BOUCOT, T. A. J. (eds.). 1970. Correlation of the North American Silurian rocks. *Spec. Pap. geol. Soc. Am.* **102**, 1-289.
- BLUSSON, S. L. 1971. Sekwi Mt. map area, Yukon Territory and District of Mackenzie. *Geol. Surv. Can. Pap.* **71-22**, 17 pp.
- BOUČEK, B., CHLUPÁČ, I. and HORNÝ, R. 1966. Silurian versus Devonian: The present state of the Siluro-Devonian boundary—problematics and proposal of solution. *Sb. nár. Mus. Praze*, **12**, 49-65.
- BOUCOT, A. J., DEWEY, J. F., DINELEY, D. L., FLETCHER, R., FYSON, W. K., GRIFFIN, J. G., HISCOX, C. F., MCKERROW, W. S. and ZIEGLER, A. M. 1974. Geology of the Arisaig Area, Antigonish County, Nova Scotia. *Spec. Pap. geol. Soc. Am.* **139**, 1-191.
- and PANKIWSKY, J. 1962. Llandoveryian to Gedinian Stratigraphy of Podolia and adjacent Moldavia. *2° Internationales Arbeitstagung über die Silur/Devon-Grenze und die Stratigraphie von Silur und Devon*, Bonn-Bruxelles 1960, 1-11.

- BROAD, D. S. 1968. *Lower Devonian Heterostraci from the Peel Sound Formation, Prince of Wales Island, Northwest Territories*. Unpublished M.Sc. Thesis, University of Ottawa. 138 pp.
- 1971. *Upper Silurian and Lower Devonian Heterostraci from Yukon and Northwest Territories, Canada*. Unpublished Ph.D. Thesis, University of Bristol. 239 pp.
- 1973. Amphiaspidiformes (Heterostraci) from the Silurian of the Canadian arctic archipelago. *Bull. geol. Surv. Can.* **222**, 35–50.
- and DINELEY, D. L. 1973. *Torpedaspis*, a new Upper Silurian and Lower Devonian genus of Cyathaspididae (Ostracodermi) from arctic Canada. *Ibid.* 53–90.
- and MIALL, A. D. 1968. The Peel Sound Formation (Devonian) of Prince of Wales and adjacent island: a preliminary report. *Arctic J. Arctic. Inst. N. Am.* **21**, 84–91.
- and LENZ, A. C. 1972. A new Upper Silurian species of *Vernonaspis* (Heterostraci) from Yukon Territory, Canada. *J. Paleont.* **46**, 415–420.
- BROTZEN, F. 1934. Erster Machweis von Unterdevon im Ostseegebiete durch Konglomeratgeschiebe mit Fischresten. *Zeitschr. Geschiebeforsch.* **10**, 1–65.
- BRYANT, W. L. 1932. Lower Devonian fishes of Bear Tooth Butte, Wyoming. Part I. *Proc. Am. phil. Soc.* **71**, 225–254.
- 1934. The fish fauna of Beartooth Butte, Wyoming. Parts II and III. *Ibid.* **73**, 127–162.
- 1935. *Cryptaspis* and other Lower Devonian fossil fishes from Beartooth Butte, Wyoming. *Ibid.* **75**, 111–128.
- BYSTROW, A. P. 1955. The microstructure of the dermal armour of jawless vertebrates from the Silurian and Devonian. *Mem. vol. A. S. Berg, Akad. Nauk. S.S.S.R.* 472–523. [In Russian.]
- 1959. The microstructure of the skeletal elements of some vertebrates from Lower Devonian deposits of the U.S.S.R. *Acta zool., Stockh.* **40**, 59–83.
- CARROLL, R. L., BELT, E. S., DINELEY, D. L., BAIRD, D. and MCGREGOR, D. C. 1972. Guide to Excursion A59, 24th Session, *Int. Geol. Congress*, Montreal 1972. 113 pp.
- CHLUPÁČ, I., JAEGER, H. and ZIKMUNDOVA, J. 1972. The Siluro-Devonian boundary in the Barrandian. *Bull. Can. Petrol. Geol.* **20**, 104–174.
- COCKS, L. R. M., HOLLAND, C. H., RICKARDS, R. B. and STRACHAN, I. 1971. A correlation of Silurian rocks in the British Isles. *Jl geol. Soc. Lond.* **127**, 103–136.
- DENISON, R. H. 1951. Evolution and Classification of the Osteostraci. *Fieldiana, Geol.* **11** (3), 157–196.
- 1952. Early Devonian fishes from Utah. Part I. Osteostraci. *Ibid.* **11** (6), 265–287.
- 1953. Early Devonian fishes from Utah. Part II. Heterostraci. *Ibid.* **11** (7), 291–355.
- 1955. Early Devonian Vertebrates from the Knoydart Formation of Nova Scotia. *Fieldiana, Zool.* **37**, 449–464.
- 1956. A review of the habitat of the earliest vertebrates. *Fieldiana, Geol.* **11** (8), 359–457.
- 1960. Fishes of the Devonian Holland Quarry Shale of Ohio. *Ibid.* **11** (10), 555–613.
- 1963. New Silurian Heterostraci from Southeastern Yukon. *Ibid.* **14** (7), 105–141.
- 1964. The Cyathaspididae: a family of Silurian and Devonian jawless vertebrates. *Ibid.* **13** (5), 309–473.
- 1966. *Cardipeltis*: an Early Devonian agnathan of the Order Heterostraci. *Ibid.* **16** (4), 89–116.
- 1967a. A new *Protaspis* from the Devonian of Utah, with notes on the classification of the Pteraspidae. *J. Linn. Soc. (Zool.)* **47** (311), 31–37.
- 1967b. Ordovician vertebrates from Western United States. *Fieldiana, Geol.* **16** (6), 131–192.
- 1968. Middle Devonian fishes from the Lemhi Range of Idaho. *Ibid.* **16** (10), 269–288.
- 1970. Revised classification of Pteraspidae with description of new forms from Wyoming. *Ibid.* **20** (1), 1–41.
- 1971. On the tail of the Heterostraci. *Forma et Functio*, **4**, 87–99.
- 1973. Growth and wear of the shield in the Pteraspidae (Agnatha). *Palaeontographica, A* **143**, 1–10.
- DINELEY, D. L. 1953. Notes on the genus *Corvaspis*. *Proc. R. Soc. Edinb. B* **65**, 166–181.
- 1964. New specimens of *Traquairaspis* from Canada. *Palaeontology*, **7**, 210–219.
- 1965. An occurrence of *Corvaspis* (Ostracodermi) in Canada. *Can. J. Earth Sci.* **2**, 93–97.
- 1966a. Fossil vertebrates from the Read Bay and Peel Sound Formation, Somerset Island, District of Franklin. *Geol. Surv. Pap. Can.* **66**–1, 12–13.
- 1966b. Geological Studies in Somerset Island, University of Ottawa expedition 1965. *Arctic*, **19**, 270–277.

- DINELEY, D. L. 1967. The Lower Devonian Knoydart faunas. *J. Linn. Soc. (Zool.)*, **47** (311), 15-29.
- 1968a. Osteostraci from Somerset Island. *Bull. geol. Surv. Can.* **165**, 49-63.
- 1968b. Palaeontology: Mackenzie Mts., District of Mackenzie. *Geol. Surv. Can. Pap.* **68-1**, 101.
- 1971. A pteraspidid in the Dalhousie Formation (Lr. Devonian) at Dalhousie, New Brunswick. *Can. J. Earth Sci.* **8**, 1603-1605.
- 1973. The fortunes of the early vertebrates. *Geology*, **5**, 2-20.
- (In press.) *Fortenaspis* from the Peel Sound Formation of Prince of Wales Island. *Occ. Pap. R. Ont. Mus. Life Sci.*
- and GOSSAGE, D. W. 1959. The Old Red Sandstone of the Cleobury Mortimer area, Shropshire. *Proc. Geol. Ass.* **70**, 221-238.
- DIXON, J., WILLIAMS, R. and TURNER, S. 1972. Stratigraphical setting of the Silurian thelodonts from Prince of Wales Island, Northwest Territories. *Lethaia*, **5**, 281-282.
- DOUGLAS, R. J. W., GABRIELSE, H., WHEELER, J. O., STOTT, D. F. and BELYEA, H. 1968. Geology of Western Canada. In DOUGLAS, J. W. (ed.). *Geology and Economic Minerals of Canada*, Ottawa, 365-488.
- and NORRIS, D. K. 1961. Camsell Bend and Root River map-areas, District of Mackenzie, Northwest Territories. *Geol. Surv. Can. Pap.* **61-13**, 36 pp.
- ELIUK, L. S. 1973. Middle Ordovician fish-bearing Beds from the St. Lawrence Lowlands of Quebec. *Can. J. Earth Sci.* **10**, 954-959.
- FÄHRAEUS, L. 1969a. Conodont zones in the Ludlovian of Gotland and a correlation with Great Britain. *Arsb. Sver. geol. Unders.* **63** (C), 1-28.
- 1969b. *Spathognathodus steinhornensis* Ziegler 1960 and the age of the Ohesaare Stage of Estonia—A reply to D. Kaljo and V. Viira. *Geol. För. Stockh. Förh.* **9**, 433-438.
- FOYNS, S. and HEINTZ, A. 1943. The Downtonian and Dittonian vertebrates of Spitsbergen. VII. The English-Norwegian-Swedish Expedition, 1939—Geological Results. *Skr. Svalbard Ishavet*, **85**, 1-49.
- FRIEND, P. F. 1961. The Devonian stratigraphy of North and Central Vestspitsbergen. *Proc. Yorks. geol. Soc.* **33**, 77-118.
- HEINTZ, N. and MOODY-STUART, M. 1966. New Unit terms for the Devonian of Spitsbergen and a new stratigraphical scheme for the Wood Bay Formation. *Årbok norsk Polarinst.* **1965**, 59-64.
- GABRIELSE, H., BLUSSON, S. L. and RODDICK, J. A. 1973. Geology of Flat River, Glacier Lake and Wrigley Lake map areas, District of Mackenzie Northwest Territories. *Mem. geol. Surv. Can.* **366** (1 and 2), 268 pp. and maps.
- GREEN, L. H., RODDICK, J. A. and BLUSSON, S. L. 1967. Nahanni map-area, District of Mackenzie and Yukon Territory. *Geol. Surv. Can. Map* 9-1967.
- GROSS, W. 1947. Die Agnathen und Acanthodier des obersilurischen Beyrichienkalks. *Palaeontographica*, **A 96**, 91-158.
- 1961. Aufbau des Panzers obersilurischer Heterostraci und Osteostraci Norddeutschlands (Geschiebe) und Oesels. *Acta zool., Stockh.* **42**, 73-150.
- 1967. Über Thelodontier-Schuppen. *Palaeontographica*, **A 127**, 1-67.
- 1969. *Lophosteus superbus* Pander, ein Teleostome aus dem Silur Oesels. *Lethaia*, **2**, 15-47.
- 1971. *Lophosteus superbus* Pander: Zähne, Zahnknochen und besondere Schuppenformen. *Ibid.* **4**, 131-152.
- GROVE, A. J. and NEWELL, G. E. 1936. An investigation into the effectual action of the caudal fin of some aquatic chordates. *Ann. Mag. nat. Hist.* **17**, 280-290.
- HALSTEAD, L. B. 1971. The Siluro-Devonian Boundary—a personal recollection. *Jl geol. Soc. Lond.* **127**, 630-632.
- 1973. The Heterostracan fishes. *Biol. Rev.* **48**, 279-332.
- and TURNER, S. 1973. Silurian and Devonian ostracoderms. In HALLAM, A. (ed.). *Atlas of Palaeobiogeography*, Amsterdam; Elsevier, 67-79.
- HARLAND, W. B. and GAYER, R. A. 1972. The Arctic Caledonides and earlier oceans. *Geol. Mag.* **109**, 189-314.
- HEINTZ, A. 1962. Les organes olfactifs des Heterostraci. *Colloques int. Cent. natn. Rech. scient.* **104**, 13-29.
- HEINTZ, N. 1960. The Downtonian and Devonian vertebrates of Spitsbergen. X. Two new species of the genus *Pteraspis* from the Wood Bay Series in Spitsbergen. *Skr. norsk. Polarinst.* **117**, 1-13.
- 1970. The Downtonian and Devonian vertebrates of Spitsbergen. XIII. The Thelodont, *Sigurdia*

- lata* n.g., n.sp. from the Lower Devonian at Sigurdfjellet, Spitsbergen. *Årbok norsk Polarinst.* **1970**, 112-116.
- HOLMAN, J. A. 1974. Report from Michigan State University. *News Bull. Soc. Vertebr. Paleont.* **100**, 28.
- JAEGER, H. 1964. Beiträge zur regionalen Geologie Thüringens und angrenzender Gebiete sowie zu anderen Problemen. *Abh. deutsch. Akad. Wiss. Berlin*, **1964**, 27-51.
- JAEKEL, O. 1927. *Der Kopf der Wirbeltiere*, Munich, pp. 815-974.
- JARVIK, E. 1964. Specialisation in early vertebrates. *Annls Soc. r. zool. Belg.* **94**, 11-95.
- 1968. Aspects of vertebrate phylogeny. In ØRVIG, T. (ed.). *Current Problems of Lower Vertebrate Phylogeny. Nobel Symposium*, **4**, 497-527.
- KALJO, D. and SARV, L. 1966. On the correlation of the Baltic Upper Silurian. *Eesti NSV Tead. Akad. Toim.* **2**, 277-287.
- KARATAJUTE-TALIMAA, V. N. 1962. Description of remains of Downtonian Agnatha from Lithuania. *Liet. TSR ma Geologijos ir Geografijos Institutas Moksliniai Pranesimai* **14**, 45-58. [Russian with English summary.]
- 1964. Data on the Stratigraphy of the Lower Devonian of the Southern Pre-Baltic. In *Questions of Stratigraphy and Palaeogeography of the Devonian Baltics*, Vilnius, 21-39. [Russian with English summary.]
- 1968a. On the stratigraphical position and correlation of the Downtonian deposits (Minija and Jura Beds) of the Baltic area. In *Stratigraphy of the Baltic Lower Palaeozoic and its correlation with other areas*, 23rd Session, Int. Geol. Congress, Prague 1968, 273-285. [Russian with English summary.]
- 1968b. New Heterostraci and Arthrodira from the Chortkovian Horizon of Podolia. *Ocherkii po filog. i sistem. isk. ryb i byesch.* Moscow, 33-42. [In Russian.]
- 1970. Downtonian fish fauna of Lithuania, Estonia and Northern Timan. In *Palaeontology and Stratigraphy of the Baltic and Byelorussia*, **11**, 33-66. [Russian with English summary.]
- KIAER, J. 1915. Upper Devonian fish remains from Ellesmere Land, with remarks on *Drepanaspis*. *Norw. Arct. Expedition in 'Fram' 1898-1902, 2nd. rep.* **33**, 21-38.
- 1932. The Downtonian and Dittonian vertebrates of Spitsbergen. IV. Suborder Cyathaspida. *Skr. Svalbard Ishavet*, **52**, 1-26.
- and HEINTZ, A. 1935. The Downtonian and Dittonian vertebrates of Spitsbergen. Suborder Cyathaspida. Part I. Family Poraspidae Kiaer. *Ibid.* **40**, 1-138.
- KOREN, T. N. 1967. Graptolite occurrences in the Borschchov Horizon of Podolia. *Int. Symposium on the Devonian System*, **2**, 493-497.
- KOSSOVOY, L. S. and OBRUCHEV, D. V. 1962. The Lower Devonian in Northern Timan. *Dokl. (Akad. Nauk. SSSR) Earth Sci.* **147**, 106-108. [Translated into English from Russian.]
- KRYLOVA, A. K., MALITCH, N. S., MENNER, V. V., OBRUCHEV, D. V. and FRADKIN, G. S. 1967. Devonian of the Siberian Platform. *Int. Symposium on the Devonian System*, **1**, 473-482. Calgary.
- LANKESTER, E. R. 1870. On a new *Cephalaspis* discovered in America. *Geol. Mag.* **75**, 397-398.
- LOEFFLER, E. J. and DINELEY, D. L. 1976. A new species of *Corvaspis* (Agnatha, Heterostraci) from the Upper Silurian to Lower or Middle Devonian of the Northwest Territories, Canada. *Palaeontology*, **19**, 757-766.
- MARK-KURIK, E. 1969. The distribution of vertebrates in the Silurian of Estonia. *Lethaia*, **2**, 145-152.
- and NOPPEL, T. 1970. Additional notes on the distribution of vertebrates in the Silurian of Estonia. *Eesti NSV Tead. Akad. Toim.* **19**, 171-173.
- MARTINSSON, A. 1967. The succession and correlation of ostracode faunas in the Silurian of Gotland. *Geol. För. Stockh. Förh.* **89**, 350-386.
- 1969. The Series of the redefined Silurian System. *Lethaia*, **2**, 153-161.
- MASHKOVA, T. V. 1967. Conodonts of the Skala and Borschchov Horizons of Podolia. *Int. Symposium on the Devonian System*, **2**, 497-501.
- MCKERROW, W. S. and ZIEGLER, A. M. 1972. Palaeozoic oceans. *Nature (P.S.)*, *Lond.* **240**, 92-94.
- MCLAREN, D. J. 1973. The Siluro-Devonian Boundary. *Geol. Mag.* **110**, 302-303.
- MILES, R. S. 1966. The acanthodian fishes of the Devonian Plattenkalk of the Paffrath Trough in the Rhineland, with an appendix containing a classification of the Acanthodii and a revision of the genus *Homalacanthus*. *Ark. Zool.* **18**, 147-194.
- 1968. Jaw articulation and suspension in *Acanthodes* and their significance. In ØRVIG, T. (ed.). *Current Problems of Lower Vertebrate Phylogeny. Nobel Symposium*, **4**, 109-127.
- 1971. *Palaeozoic Fishes*. London; Chapman and Hall. 259 pp.



- MUTVEI, H. 1956. Découverte d'une riche microfaune dans la calcaire silurien de la région de la Saoura (Sahara du Nord). *Compt. Rend. Acad. Sci. Paris*, **243**, 1653-1654. (Cited in Halstead and Turner 1973.)
- NIKIFOROVA, O. I., PREDTECHENSKY, N. N. and ABUSHIK, A. F. 1967. The importance of the Silurian Section of Podolia for the definition of the Siluro-Devonian boundary in Europe. *Int. Symposium on the Devonian System*, **2**, 867-873. Calgary.
- NORRIS, A. W. 1968. Reconnaissance Devonian Stratigraphy of N. Yukon Territory of N.W. District of Mackenzie. *Geol. Surv. Can. Pap.* **67-53**, 287 pp.
- NOVITSKAYA, L. I. 1970. Late Silurian *Archegonaspis* (Agnatha) on Vaygach Island. *Paleont. J.* **4**, 388-396.
- 1973. *Liliaspis*—ein Poraspide aus dem Unterdevon des Urals und einige Bemerkungen über die Phylogenie der Poraspiden (Agnatha). *Palaeontographica*, **A 143**, 25-34.
- OBRUCHEV, D. V. 1938. Vertebrata aus dem Obersilur und Devon des Urals. *Materialy Ts NIGRI, obshchaya seriya*, **2**, 36-43, pls. 1-2. [Russian with German summary.]
- 1945. The Evolution of the Agnatha. *Zool. Zh.* **24**, 257-272. [In Russian.]
- 1958. On the biostratigraphy of the lower and middle Palaeozoic ichthyofaunas of the USSR. *Sov. Geol.* **11**, 40-53. [Russian with English summary.]
- 1964. Agnatha, Pisces. In *Fundamentals of Palaeont.* **11**. Moscow (Translation: Israel Program for Scientific Translations, Jerusalem 1967.)
- 1967. On the evolution of the Heterostraci. In LEHMAN, J. P. (ed.). *Colloques int. Cent. natn. Rech. scient.* **104**, 13-29.
- and KARATAJUTE-TALIMAA, V. N. 1967. Vertebrate faunas and correlation of the Ludlovian-Lower Devonian in E. Europe. *J. Linn. Soc. (Zool.)*, **47** (311), 1-4.
- — 1968. Vertebrate faunas and correlation of the Ludlow and Lower Downtonian remains of E. Europe. *Ocherki po filog. i sistem isk. ryb. i byesch.* Moscow, 63-70. [In Russian.]
- ØRVIG, T. 1951. Histologic studies of Placoderms and fossil Elasmobranchs. 1. The endoskeleton, with remarks on the hard tissues of lower vertebrates in general. *Ark. Zool.* **2**, 321-454.
- 1957. Remarks on the vertebrate fauna of the lower Upper Devonian of Escuminac Bay P.Q., Canada, with special reference to the Porolepiform Crossopterygii. *Ibid.* **10**, 367-426.
- 1961. Notes on some early representatives of the Drepanaspida (Pteraspitomorphi). *Ibid.* **12**, 515-535.
- 1968. The dermal skeleton; general considerations. In ØRVIG, T. (ed.). *Current Problems of Lower Vertebrate Phylogeny. Nobel Symposium*, **4**, 81-87.
- 1969a. The vertebrate fauna of the *primaeva* beds of the Fraenkelryggen Formation of Vestspitsbergen and its biostratigraphic significance. *Lethaia*, **2**, 219-239.
- 1969b. Thelodont scales from the Grey Hoek Formation of Andrée Land, Spitsbergen. *Norsk geol. Tidsskr.* **49**, 387-401.
- PAGEAU, Y. 1968. Nouvelle fauna ichthyologique du Devonian moyen dans les Grés de Gaspé (Quebec). 1. Geologie et Ecologie. *Naturaliste can.* **95**, 1459-1497.
- 1969. Nouvelle fauna ichthyologique du Devonian moyen dans les Grés de Gaspé (Quebec). 2. Geologie et Ecologie. *Ibid.* **96**, 399-478.
- P'AN, KIANG. 1962. A new silurian fish from Nanking, China. *Acta palaeont. sin.* **10**, 402-409. [Chinese with English summary.]
- PANDER, C. H. 1856. *Monographie der Fossilen Fische des silurischen Systems der russisch-baltischen Gouvernements*. St. Petersburg, 96 pp.
- RITCHIE, A. 1967. *Phlebolepis elegans* Pander, an Upper Silurian thelodont from Oesel, with remarks on the morphology of thelodonts. In ØRVIG, T. (ed.). *Current Problems of Lower Vertebrate Phylogeny. Nobel Symposium*, **4**, 81-87.
- ROBERTSON, G. M. 1936. New cephalaspids from Canada. *Am. J. Sci.* **31**, 288-295.
- ROHON, J. V. 1889. Über untersilurische Fische. *Izv. imp. Akad. Nauk.* **1**, 269-277.
- ROMER, A. S. and GROVE, B. H. 1935. Environment of the early vertebrates. *Amer. Midl. Nat.* **16**, 805-856.
- RUSSELL, L. S. 1947. A new locality for fossil fishes and eurypterids in the Middle Devonian of Gaspé, Quebec. *Contr. R. Ont. Mus. Palaeont.* **12**, 1-6.
- SCHAEFER, W. 1972. *Ecology and Palaeoecology of Marine Environments*. Edinburgh, 568 pp.
- SCHMIDT, W. 1959. Grundlagen einer Pteraspiden-Stratigraphie im Unterdevon der Rheinischen Geosynklinale. *Fortschr. Geol. Rheinld. Westf.* **5**, 1-82.

- SHAW, R. W. L. 1969. Beyrichiacean ostracodes from the Downtonian of Shropshire. *Geol. Fören. Stockh. Förh.* **91**, 52-79.
- SMITH, A. G., BRIDEN, J. C. and DREWRY, G. E. 1973. Phanerozoic world maps. *Spec. Pap. Palaeontol.* **12**, 1-42.
- SQUIRRELL, H. C. 1973. The Downtonian-Dittonian boundary. *J. Geol. Soc.* **129** (2), 205-206.
- and DOWNING, R. A. 1969. The geology of the South Wales Coalfield. Part I. *Mem. Geol. Surv. G.B.* 1-133.
- STENSIÖ, E. A. 1927. The Downtonian and Dittonian vertebrates of Spitsbergen. 1. Family Cephalaspididae. *Skr. Svalbard Ishavet.* **12**, 1-391.
- 1932. The Cephalaspids of Great Britain. *Br. Mus. (nat. Hist.), London.* Pp. 220, 66 pls.
- 1944. Contributions to the knowledge of the vertebrate faunas of the Silurian and Devonian of W. Podolia. II. Notes on Arthrodiros from the Downtonian of Podolia. *Ark. Zool.* **35**, 1-83.
- 1958. Les cyclostomes fossiles ou Ostracodermes. In GRASSÉ, P. P. (ed.). *Traité de Zoologie* **13** (1), 173-425. Paris.
- 1964. Les cyclostomes fossiles ou Ostracodermes. In PIVETEAU, J. (ed.). *Traité de Paléontologie*, **4** (1), 96-385. Paris.
- TARLO, L. B. 1958. Ostracoderms of Emsian age from the Lower Devonian rocks of central Poland. *Proc. geol. Soc. Lond.* **1564**, 6-9.
- 1960. The Downtonian ostracoderm *Corvaspis kingi* Woodward, with notes on the development of dermal plates in the Heterostraci. *Palaeontology*, **3**, 217-226.
- 1961. *Rhinopteraspis cornubica* (McCoy), with notes on the classification and evolution of the pteraspids. *Acta palaeont. pol.* **6**, 367-400.
- 1962a. The classification and evolution of the Heterostraci. *Ibid.* **7**, 249-290.
- 1962b. Lignées évolutives chez les ostracodermes hétéostraces. *Colloques int. Cent. natn. Rech. scient.* **104**, 31-37.
- 1964. Psammosteiformes (Agnatha). A review with descriptions of new material from the Lower Devonian of Poland. I. General Part. *Palaeont. pol.* **13**, 1-135.
- 1965. Psammosteiformes (Agnatha). A review with descriptions of new material from the Lower Devonian of Poland. II. Systematic Part. *Ibid.* **15**, 1-168.
- TAYLOR, G. C. and MACKENZIE, W. S. 1970. Devonian stratigraphy of northeastern British Columbia. *Bull. geol. Surv. can.* **186**, 7-62.
- THORSTEINSSON, R. 1958. Cornwallis and Little Cornwallis Islands, District of Franklin, Northwest Territories. *Mem. Geol. Surv. Can.* **294**, 134 pp.
- 1967. Preliminary note on Silurian and Devonian ostracoderms from Cornwallis and Somerset Islands, Canadian Arctic Archipelago. *Colloques int. Cent. natn. Rech. scient.* **163**, 45-47.
- 1973. Dermal elements of a new lower vertebrate from Middle Silurian (Upper Wenlockian) rocks of the Canadian Arctic Archipelago. *Palaeontographica, A* **143**, 51-57.
- and TOZER, W. 1963. Geology of northern Prince of Wales Island and northwestern Somerset Island. In FORTIER *et al.* *Geology of the N. Central part of the Arctic Archipelago*, *Mem. geol. Surv. Can.* **320**, 117-129.
- TOOMBS, H. A. and RIXON, A. E. 1950. The use of plastics in the 'Transfer Method' of preparing fossils. *Museums J.* **50**, 105-107.
- TRAQUAIR, R. H. 1890. Notes on the Devonian fishes of Scaumenac Bay and Campbellton in Canada. No. 1. *Geol. Mag.* **7**, 15-22.
- 1893. Notes on the Devonian fishes of Campbellton and Scaumenac Bay in Canada. No. 2. *Ibid.* **10**, 145-149.
- 1894. On *Cephalaspis magnifica*, a new fossil fish from the Caithness flagstones. *Proc. R. phys. Soc. Edinb.* **12**, 269-273.
- TURNER, S. 1973. Siluro-Devonian thelodonts from the Welsh Borderland. *J. geol. Soc. Lond.* **129**, 557-584.
- and DIXON, J. 1971. Lower Silurian thelodonts from the Transition Beds of Prince of Wales Island, Northwest Territories. *Lethaia*, **4**, 385-392.
- WÄNGSJÖ, G. 1952. The Downtonian and Devonian vertebrates of Spitsbergen. IX. Morphologic and systematic studies of the Spitsbergen cephalaspids. *Skr. norsk Polarinst.* **97**, 1-611.
- WATSON, D. M. S. 1954. A consideration of ostracoderms. *Phil. Trans. R. Soc. B* **238**, 1-25.

- WESTOLL, T. S. 1945. A new cephalaspid fish from the Downtonian of Scotland, with notes on the structure and classification of the ostracoderms. *Trans. R. Soc. Edinb.* **61**, 341-357.
- 1967. *Radotina* and other tesserate fishes. *J. Linn. Soc. (Zool.)*, **47** (311), 83-98.
- SHIRLEY, J., DINELEY, D. L. and BALL, H. W. 1971. The Siluro-Devonian boundary, a written contribution to the paper 'A correlation of Silurian rocks in the British Isles'. *J. geol. Soc. Lond.* **127**, 285-288.
- WHITE, E. I. 1935. The ostracoderm *Pteraspis* Kner and the relationships of the agnathous vertebrates. *Phil. Trans. R. Soc. B* **225**, 381-457.
- 1946. The genus *Phialaspis* and the 'Psammosteus Limestones'. *Q. J. geol. Soc. Lond.* **101**, 207-242.
- 1950a. Vertebrate faunas of the Lower Old Red Sandstone of the Welsh borders. *Bull. Br. Mus. nat. Hist. (Geol.)*, **1**, 51-67.
- 1950b. *Pteraspis leathensis* White, a Dittonian zone fossil. *Ibid.* **1**, 69-89.
- 1956. Preliminary note on the range of pteraspids in W. Europe. *Bull. Inst. r. Sci. nat. Belg.* **32**, 1-10.
- 1958. Original environment of the craniates. In WESTOLL, T. S. (ed.). *Studies on fossil vertebrates*. London, Athlone Press, pp. 212-233.
- 1960. Notes on pteraspids from Artois and the Ardennes. *Bull. Inst. r. Sci. nat. Belg.* **36**, 1-15.
- 1961. The Old Red Sandstone of Brown Clee Hill and the adjacent area. II. Palaeontology. *Bull. Br. Mus. nat. Hist. (Geol.)*, **5**, 243-310.
- 1973. Form and growth in *Belgicaspis* (Heterostraci). *Palaeontographica, A* **143**, 11-24.
- and TOOMBS, H. A. 1948. Guide to Excursion C16. *18th Session, Int. Geol. Congress, London*, 4-14.
- WILLIAMS, A. 1969. Ordovician of the British Isles. In KAY, M. (ed.). *North Atlantic geology and continental drift. Mem. Am. Ass. Petrol. Geol.* **12**, 236-264.
- WOODWARD, A. S. 1934. A new cyathaspidian fish from the Upper Downtonian rocks of Corvedale. *Q. J. geol. Soc. Lond.* **90**, 566-567.
- ZYCH, W. 1931. *Fauna ryb Devonii i Downtoni Podola*. Lwow, 91 pp.

D. L. DINELEY and E. J. LOEFFLER  
 Department of Geology  
 University of Bristol  
 Queen's Building, University Walk  
 Bristol BS8 1TR

Typescript received 10 February 1975

Revised typescript received 16 December 1975