

EVOLUTION AND PHYLOGENETIC CLASSIFICATION OF THE DIPLOGRAPTACEA

by CHARLES E. MITCHELL

ABSTRACT. The complex astogenetic patterns produced by the specialized, first few thecae (primordial thecae) of graptoloid rhabdosomes were conserved during evolution and provide a reliable guide to 'propinquity of descent' among diplograptids. Using this principle one can redefine their taxonomy, establish phylogenetically meaningful higher taxa, and obtain an improved understanding of diplograptacean phylogeny. The Diplograptacea comprises four major subclades. 1, Orthograptidae: archaic orthograptids (species of the '*Glyptograptus teretiusculus* species group), *Orthograptus* and *Amplexograptus*, together with archiretiolitids, lasiograptids, and '*Climacograptus*' *typicalis*-*G. lorrainensis* groups; 2, Dicranograptidae: dicranograptids plus nemagraptids; 3, Diplograptidae: pseudoclimacograptids and *Climacograptus* s.s., together with *Diplograptus* s.s. and offshoots; 4, Monograptidae: '*G. dentatus* and descendants including *Undulograptus paradoxus*, *G. euglyphus*, '*C. normalis*, and all the Silurian diplograptids including the uniserial monograptines. The first three families dominated Ordovician faunas. Taxa with complex proximal end structures were succeeded during the Llandeilo and Caradoc by taxa with simpler astogenies. Following extinction of the dominant Ordovician taxa, monograptids (*sensu lato*) underwent explosive evolution in the Llandovery. New generic group taxa: *Archiclimacograptus*, *Arnheimograptus*, *Diplacanthograptus*, *Eoglyptograptus*, *Geniculograptus*, *Hustedograptus*, *Oelandograptus*, *Pseudamplexograptus*, and *Urbanekograptus*. New family group taxa: Eoglyptograptinae and Orthograptidae.

THE first-formed few thecae of graptoloid colonies exhibit specialized ontogenies. These specialized features are largely prothecal in origin and are associated with the formation of the primary stipes. Elles (1922), and later Bulman (especially 1933a and 1936), grouped graptoloid astogenies into a series of 'developmental types' distinguished from one another by budding pattern, direction of thecal growth, and position of the dicalycal theca in the budding sequence. These general developmental types were defined following the recognition that graptoloid astogeny displayed a limited range of basic patterns and that individual patterns characterized large segments of the Graptoloidea.

The early astogeny of members of the Suborder Diplograptina Bulman, 1970 is especially complex. Each of the first several thecae exhibit unique features and ontogenetic patterns that are orchestrated to establish the foundation of the rhabdosome. This complex orchestration is, in turn, repeated with great precision among all members of a given species—a regularity not unlike that of the metathecal morphoclines exhibited by monograptids (Bulman 1968, p. 1353; Urbanek 1973). Despite these seemingly useful features, graptoloid (and particularly diplograptinid) astogeny has been largely ignored in both systematic and phylogenetic studies of these organisms. Astogenetic pattern has been seen as simply another of the many features of graptoloid colonies that underwent extensive parallel change (Bulman 1933a, p. 2) and so bears no consistent relationship to taxonomy: '[T]he *Diplograptus* type of development . . . exhibits considerable modifications which occur indiscriminately in the various genera and sub-genera [of the Diplograptidae] . . .' (1933a, p. 3). This treatment of astogeny has remained the standard approach, e.g. Urbanek's (1959, p. 326) discussion of *Gymnograptus* astogeny and Rickards *et al.*'s (1977, p. 23) discussion of the appearance of the monograptid condition.

Cooper and Fortey (1982, 1983), Kearsley (1982, 1985), and Mitchell (1981, 1986) have argued for a different interpretation of astogenetic similarity. We have each independently concluded that graptoloid astogeny shows a striking parallelism with von Baer's Law, i.e. that primordial

astogenetic features were not altered with great ease or frequency but rather were highly conserved during the evolution of graptoloid colonial design. The features of early astogenetic stages and the sicula were more refractory to change than were later stages in astogeny. In most cases, detailed structural and developmental similarities in early astogeny among graptoloids are *homologies*. Accordingly, these can and should be used to determine evolutionary relationships among graptolites and to establish a phylogenetic classification. I have presented a theoretical basis for this view, together with detailed supporting evidence, elsewhere (1986; see also Gould 1977 for a discussion of von Baer's law).

There are now sufficient data available on the astogeny of the Diplograptina to permit an accurate survey of the range of their developmental patterns. I believe that the distribution of these data across the group is also sufficient to trace the outlines of the phylogenetic history of this complex and interesting group and to begin the reorganization of the traditional diplograptinid form taxa into more meaningful units.

DIPLOGRAPPTINID ASTOGENETIC PATTERNS

Primitively, the Diplograptina exhibit an early astogenetic pattern in which each of the first four thecae have specialized ontogenies. For convenience, we may refer to these specialized, first few thecae of graptolite colonies as *primordial thecae* (adapting somewhat a term employed early in the study of graptolites: see Holm 1895), and to that part of astogeny that encompasses the growth of these thecae as the *primordial astogeny*. Among primitive diplograptinids $th1^2$ is dicalycal and $th2^1$ to $th2^2$ include crossing canals. This is essentially the definition of the *Diplograptus* developmental type of Elles (1922). Bulman (1936) subdivided this pattern into a number of 'stages' (again seen solely as grades of organization) as part of his study of graptoloid orthogenesis. While retaining the general definition for the *Diplograptus* developmental type, with its emphasis on three crossing canals, Bulman (1963*a*, 1970) later abandoned these 'stages' and simply recognized two grades of organization among the range of diplograptinid developmental patterns: 1, the primitive streptoblastic condition in which $th1^2$ is S-shaped and initially grows upwards from its origin; and 2, the derived prosoblastic condition in which $th1^2$ is J-shaped and the initial upward growth is lost. This simple structural distinction does indeed appear to have been crossed repeatedly during the evolu-

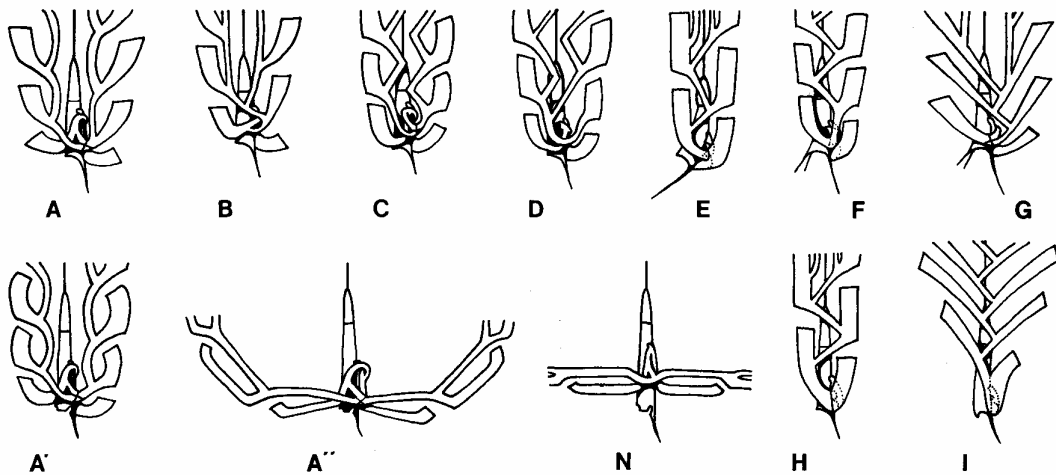

TEXT-FIG. 1. Thecal diagrams of the diplograptid astogenetic Patterns A-I (letter designations are those used to refer to these patterns throughout the text).

tion of the Diplograptina. Consequently, I do not place any great emphasis on it in the definition of the diplograptinid primordial astogenetic patterns, except to note that the streptoblastic condition is restricted to the more primitive members of the group (i.e. those with astogenetic Patterns A, B, and C, see discussion of these patterns below). I believe these astogenetic patterns have strict phylogenetic significance.

The Diplograptina and the Dicranograptidae (including *Leptograptus*: see Finney 1985) are characterized by the unique left-handed origin of $th1^2$ from $th1^1$. Fuselli from the obverse side of

TABLE 1. Generic assignments of Ordovician 'diplograptid' species with known primordial astogeny (* = type species).

Pattern A

HUSTEDOGRAPTUS gen. nov.: *Diplograptus notabilis* Hadding, *D. propinquus* Hadding, *D. uplandicus* Wiman*, *Glyptograptus teretiusculus* sensu Jaanusson, *G. vikarbyensis* Jaanusson. OELANDOGRAPTUS gen. nov.: *Glyptograptus americanus* Bulman, *G. austrodentatus* Harris and Keble, *G. oelandicus* Bulman*, *G. sinodentatus* Mu and Lee.

Pattern B

EOGLYPTOGRAPTUS gen. nov.: *Glyptograptus cernuus* Jaanusson, *G. dentatus* (Brongniart)*, *Pseudoclimacograptus jaroslovi* Bouček. UNDULOGRAPTUS Bouček, 1973: *Climacograptus paradoxus* Bouček*.

Pattern C

DICAULOGRAPTUS Rickards and Bulman, 1965: *D. hystrix* (Bulman)*, *D. cumdiscus* Finney. DIPLOGRAPTUS M'Coy, 1850: *D. foliaceus* (Murchison), *D. molestus* Thorslund, *D. pristis* (Hisinger)*. PROLASIOGRAPTUS Lee, 1963: *Lasiograptus haplus* Jaanusson. PSEUDAMPLEXOGRAPTUS gen. nov.: *Amplexograptus coelatus* (Lapworth), *A. munimentus* Berry, *A. maxwelli* Ekström, *Climacograptus distichus* (Eichwald)*, *C. meridionalis* Ruedemann, *Pseudoclimacograptus vestergothicus* Jaanusson and Skoglund. PSEUDOCLIMACOGRAPTUS Přibyl, 1947: P. (ARCHICLIMACOGRAPTUS) subgen. nov.: *P. angulatus angulatus* (Bulman), *P. angulatus sebyensis* Jaanusson*, *P. cumbrensis* Bulman, *P. eurystoma* Jaanusson, *P. klabavensis* Bouček, *P. luperus* Jaanusson, *P. marathonsensis* Clarkson, *P. modestus* Ruedemann, *P. oliveri* Bouček. URBANEKOGRAPTUS gen. nov.: *Gymnograptus retioloides* (Wiman)*.

Pattern D

P. (PSEUDOCLIMACOGRAPTUS) Přibyl, 1947: *P. clevensis* Skoglund, *P. scharenbergi* (Lapworth)*. CLIMACOGRAPTUS Hall, 1865: C. (CLIMACOGRAPTUS): *C. bicornis* (Hall)*, *C. caudatus* Lapworth, *C. putillus* (Hall), *C. styloideus* Lapworth.

Pattern E

CLIMACOGRAPTUS (DIPLACANTHOGRAPTUS) subgen. nov.: *C. dorotheus* Riva, *C. longispinus* T. S. Hall, *C. spiniferus* Ruedemann*, *C. venustus* Hsu.

Pattern F

ARNHEIMOGRAPTUS gen. nov.: *Glyptograptus anacanthus* Mitchell and Bergström*, *G. hudsoni* Jackson, *G. lorrainensis* Parks. GENICULOGRAPTUS gen. nov.: *Climacograptus inuiti* Cox, *C. pygmaeus* Ruedemann, *C. typicalis* Hall*. GYMNAGRAPTUS Bulman, 1953: *G. limarssoni* (Moberg)*.

Pattern G

AMPLEXOGRAPTUS Lapworth, Elles and Wood, 1907: *A. bekkeri* (Öpik), *A. elongatus* Barrass, *A. fallax* Bulman, *A. cf. fallax* Jaanusson and Skoglund, *A. leptotheca* (Bulman), *A. maxwelli* Decker. HALLOGRAPTUS Lapworth, 1876: *H. bimucronatus* (Nicholson)*. LASIOGRAPTUS Lapworth, 1873: *L. harknessi* (Nicholson). NEUROGRAPTUS Elles and Wood, 1908: *N. bulmani* Strachan, *N. margaritatus* Lapworth*. ORTHOGRAPTUS Lapworth, 1873: *O. amplexicaulis* Hall, *O. apiculatus* (Elles and Wood), *O. gracilis* Roemer, *O. quadrimucronatus* (Hall)*, *O. ruedemanni* Gurley, *O. truncatus* (Lapworth). ORTHORETIOLITES Whittington, 1954: *O. hami* Whittington*. PARAORTHOGRAPTUS Mu et al., 1974: *Climacograptus pacificus* Ruedemann*. PEIRAGRAPTUS Strachan, 1954: *P. fallax* Strachan*. PIPIOGRAPTUS Whittington, 1955: *P. hesperus* Whittington*.

Pattern H

GLYPTOGRAPTUS Lapworth, 1873: *Climacograptus angustus* (Perner), *C. brevis* Elles and Wood, *C. brevis mutabilis* Strachan, *C. kuckersianus* Wiman, *C. normalis* Lapworth, *C. rotundatus* Jaanusson and Skoglund, *Diplograptus toernquisti* Hadding, *Glyptograptus euglyphus* Lapworth.

th1¹ swing around the theca and form a hood over the foramen in the reverse side of th1² (see, for instance, text-figs. 2E, 6B, 9I, J). The foramen of th1² is completed, as is the contribution of th1¹ to the hood of th1², when the next fusellus passes around th1¹ to meet with the reverse wall of th1¹ or the sicula, rather than continuing around the leading edge of the hood (e.g. text-figs. 2E and 9A, D). Following the completion of the hood of th1², the crossing canal of th1² begins to grow downward, across the reverse side of the sicula. I employ the term 'crossing canal' to refer *only* to the sicula-crossing, tubular prothecae of primordial thecae. Diplograptinid structures force this restriction of the term because species with a comparatively simple primordial astogeny and a delayed dicalycal theca (such as *Amplexograptus bekkeri*, in which th3¹ is dicalycal) could be said to have four or five crossing canals, several of which differ in no significant structural way from later thecae. Hence, the term 'crossing canal' retains greater meaning if restricted in its application to the prothecae of the specialized early thecae that cross the sicula.

Beyond its initial origin the growth of th1² includes several major variants among the Diplograptina and, together with the ontogenetic variations exhibited by the crossing canals of th2¹ and th2², these variants define nine basic primordial astogenetic patterns. The exact position of the dicalycal theca contributes very little to the distinctiveness of the patterns, however. In almost any given pattern, some species possess a delayed dicalycal theca. However, the level of the dicalycal theca's *earliest occurrence* within each astogenetic pattern is of significance. Consequently, I do not use Cooper and Fortey's (1983, p. 171) two diplograptinid 'developmental types', which they recognized on the basis of the position of the dicalycal theca.

The nine diplograptinid primordial astogenetic patterns are illustrated diagrammatically in text-fig. 1 and have been designated 'A'-'I', roughly in stratigraphic order of first appearance, elsewhere (Mitchell 1986). I have chosen not to name them after seemingly typical species or genera. None of these patterns are invariant. To name them after a particular taxon promotes a stereotypic and,

B-D, J, *Oelandograptus* (gen. nov.) *austrudentatus oelandicus* (Bulman in Skevington 1965) exhibiting Pattern A primordial astogeny; Hølen Limestone, Kunda Stage (Hunderumian Substage, *D. hirundo* Zone), Hälludden, Öland. B, C, Cn 59911 (from horizon - 120D), obverse and reverse views; note quasi-symmetrical disposition of primordial thecae, × 20. D, Cn 59892 (Holm Collection), showing streptoblastic crossing canal of th1² and left-handed origin of th2¹, × 20. J, Cn 59891 (Holm Collection), note visible th2¹ descending crossing canal and undulating median septum formed by successive prothecae, × 9.

H, R, *Dicranograptus nicholsoni longibasalis* Ruedemann and Decker, Viola Springs Formation (0.3 m above base of section D; Alberstadt 1973), Rocklandian Stage (upper *C. bicornis* Zone), Arbuckle Mtns., Oklahoma. H, MCZ 9461/1, young growth stage equivalent to D; note dorsal notch, lateral lappets, and paired notches adjacent to virgella, × 14. R, MCZ 9461/2, obverse view showing dicranograptid sicula and prominent nema, × 9.

I, N, Q, *Pseudoclimacograptus* (*Archiclimacograptus* subgen. nov.) *angulatus sebyensis* Jaanusson exhibiting Pattern C primordial astogeny; Holm Collection, Folkeslunda Limestone, Lasnamägi Stage (*G. teretiusculus* Zone). I, Cn 59885, Gårdslösa, Öland, specimen showing streptoblastic th1² with origin of th2¹ from its right side (specimen damaged subsequent to sketching), × 20. N, Q, Cn 59803, Sjöstorp, Öland, obverse and reverse views, × 20.

L, M, *Hustedograptus* (gen. nov.) *teretiusculus sensu* Jaanusson, 1960, Cn 59886, Folkeslunda Limestone, Lasnamägi Stage (*H. teretiusculus* Zone), Sjöstorp, Öland (Holm Collection), obverse and reverse views; note paired lappets on dorsal margin of sicula, prominent crossing canal of th2¹, and dicalycal th2², × 20.

O, P, *Pseudamplexograptus* (gen. nov.) *distichus* (Eichwald), exhibiting Pattern C primordial astogeny; Folkeslunda Limestone, Lasnamägi Stage (*G. teretiusculus* Zone), Lerkaka, Öland (Holm Collection). O, Cn 59922, showing formation of th2¹-th2² and foramen from which th3¹ arises. P, Cn 59921, note right-handed origin of th2¹ from th1², both × 20.

Abbreviations: an, ancora; av, antivirgellar spines; cc, crossing canal; dt, dicalycal theca; fl, upward growing flange; fo, foramen; la, lappets; ls, list scar; m, mesial spine; ms, median septum; s, sicula; p, protheca; pr, prothecal rods; v, virgella. Repositories: BMNH, British Museum (Natural History), London; MCZ, Museum of Comparative Zoology, Harvard University; Cn, Naturhistoriska Riksmuseet, Stockholm; SM, Sedgwick Museum, Cambridge University; Öl and Vg, Paleontological Institute, Uppsala University; USNM, United States National Museum, Smithsonian Institution, Washington.

at times, seriously distorted view of the astogenetic patterns. Finally, these patterns do not apply to the Silurian retiolitids (although most of the archiretiolitids are encompassed by the scheme). Table 1 indicates the astogenetic pattern of more than eighty diplograptinid species known in relief or from isolated preparations, and for which I have been able to obtain data. The stratigraphic range of the genera exhibiting these patterns is indicated in text-fig. 17.

Pattern A (text-fig. 2A-H, J-M, R)

The sicula is straight. Its aperture is commonly plain except for a prominent virgella. In a few species the aperture is elaborated in the form of a pair of antivirgellar lappets or antivirgellar spines. The crossing canal of $th1^2$ is usually streptoblastic. $Th1^2$ gives rise to the crossing canal of $th2^1$ from its left side by bifurcation of a broad hood formed early in the ontogeny of $th1^2$ (text-fig. 2D, H). The crossing canal of $th2^1$ also grows downward, toward the virgella and along the reverse wall of $th1^1$. An isolated fusellar flange forms near the sicular aperture in advance of the approaching crossing canal of $th2^1$, and grows upwards. They fuse and form a symmetrical pair of foramina from which the metatheca of $th2^1$ arises on the biological left side, and of $th2^2$ on the right (text-fig. 2A). From this point, both thecae grow upward and surround the crossing canal of $th2^1$, which remains visible for a large part of its length. There are, thus, four primordial thecae and three crossing canals ($th1^2$ - $th2^2$). Either $th2^1$ or some later theca may be dicalycal.

In obverse view, both $th1^1$ and $th1^2$ diverge widely from the sicula, forming a blunt to broadly rounded proximal end that is usually sub-symmetrical. $Th2^1$ and $th2^2$ enclose the sicula together with subsequent thecae. In species exhibiting a Pattern A astogeny, the median septum may be undulating to straight, and their post-primordial thecae range in shape from glyptograptid to orthograptid. Species exhibiting Pattern A include the earliest known diplograptinids. This developmental pattern is also found throughout the Dicranograptidae, as noted by Bulman (1970, pp. V76-V78).

Pattern B (text-fig. 3A-E, I, J)

The sicula is straight to slightly deflected. The sicular aperture bears only a short stout virgella. $Th1^2$ may be prosoblastic or streptoblastic. The crossing canal of $th1^2$ grows downward obliquely across the sicula and away from $th1^1$. The third theca arises from $th1^2$ on its left side, as in Pattern A. $Th2^1$ grows downward at first and then turns upward before giving rise to $th2^2$. $Th2^2$ arises by a pattern of differentiation like that of distal thecae. The dicalycal theca may be $th2^1$ or later. The median septum may be undulating to straight. There are three primordial thecae and two crossing canals ($th1^2$ and $th2^1$). The proximal end is asymmetric with the first two thecal apertures at markedly different levels. In obverse view the sicula is exposed only to the level of the aperture of $th1^1$ or $th1^2$. Thecal shapes among species exhibiting Pattern B range from glyptograptid to climacograptid. This pattern is relatively poorly known: only the primordial astogeny of *Glyptograptus dentatus* (Brongniart) and *Undulograptus paradoxus* (Bouček) (= *Climacograptus pauperatus* Bulman) are known in any detail (Bulman 1963a).

Pattern C (text-figs. 2I, N-Q, 4A-O)

The sicula is straight and generally slender. With rare exceptions (e.g. *Dicaulograptus hystrix* (Bulman), text-fig. 4), the sicular aperture bears only a virgella. The growth of $th1^2$ - $th2^2$ is like that seen in Pattern A, except that the crossing canal of $th2^1$ arises from the *right* side of $th1^2$. $Th2^1$ (or rarely, $th2^2$) is dicalycal. Among a large number of early species, $th3^1$ originates from a foramen in the metatheca of $th2^1$ (text-figs. 2O, Q, 4E). This feature commonly produces what appears to be a continuous arch connecting $th2^2$ and $th3^1$ (see text-fig. 4L). Because the crossing canal of $th2^1$ must swing out and away from the sicula a considerable distance to grow around $th1^2$, it is commonly exposed as a diamond-shaped patch in the central region of the rhabdosome above the $th2^2$ - $th3^1$ arch. This feature is exhibited clearly by *Pseudoclimacograptus oliveri* Bouček and *P. angulatus* (Bulman 1953, text-figs. 1b and 2b, respectively, but note that the origin of $th2^1$ in his text-figs. 1c

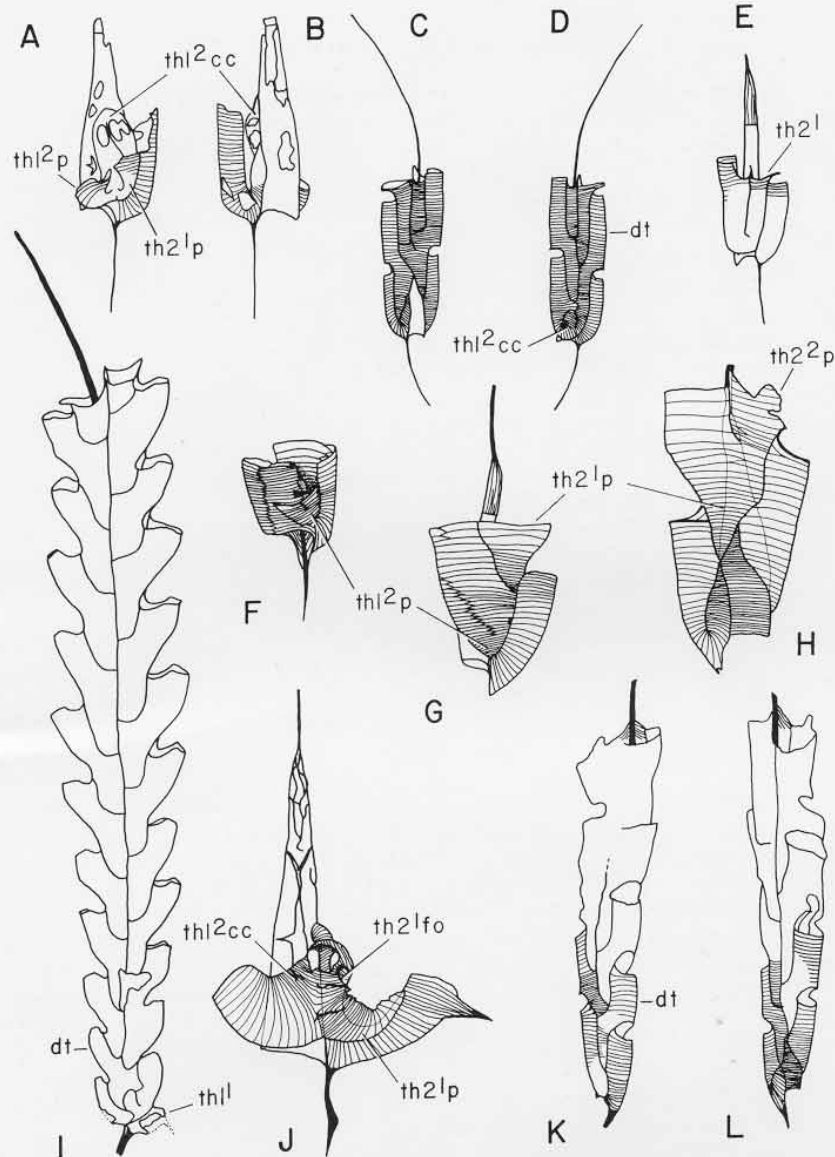

TEXT-FIG. 3. Camera lucida drawings of species exhibiting Pattern B and Pattern H primordial astogenies. See text-fig. 2 for explanation of abbreviations and specimen repositories.

A-E, *Undulograptus paradoxus* (Bouček), Seby Limestone, Lasnamägi Stage (*D. purchisoni* Zone), Seby, Öland. A, B, Öl unnumbered, reverse and obverse views of early growth stage showing streptoblastic $th1^2$ and delayed origin of $th2^1$, $\times 32$. C, D, Öl 983, obverse and reverse views; note budding sequence with dicalycal $th2^1$, $\times 16$. E, Öl unnumbered, reverse view; note paired $th1^2$ and $th2^1$, $\times 20$.

F-H, K, L, *Glyptograptus brevis* (Elles and Wood), 'Climacograptus band', Balclatchie beds, Caradoc Series ('*D. multidentis* Zone), Laggan Burn, Ayrshire, Scotland. F, MCZ 9462/1, oblique reverse view showing list that links free reverse wall of $th1^1$ with sicula, $\times 32$. G, MCZ 9462/2, reverse view; note origin of $th2^1$, $\times 26$. H, MCZ 9462/3, obverse view; note origin of $th2^2$ by simple distal differentiation, $\times 32$. K, L, MCZ 9462/4, reverse and obverse views; specimen partly flattened distally to present sub-scalariform view, $\times 15$.

I, J, *Eoglyptograptus* (gen. nov.) *dentatus* (Brongniart) *sensu* Bulman, 1963a, Hølen Limestone, Kunda Stage (*D. bifidus* Zone), +0+15D, Hagudden, Öland. I, Cn 59937, note shape of proximal end and cusped thecal apertures, $\times 10$. J, Öl 1228, early $th2^1$ stage; see text and Skevington (1965) for further discussion, $\times 34$.

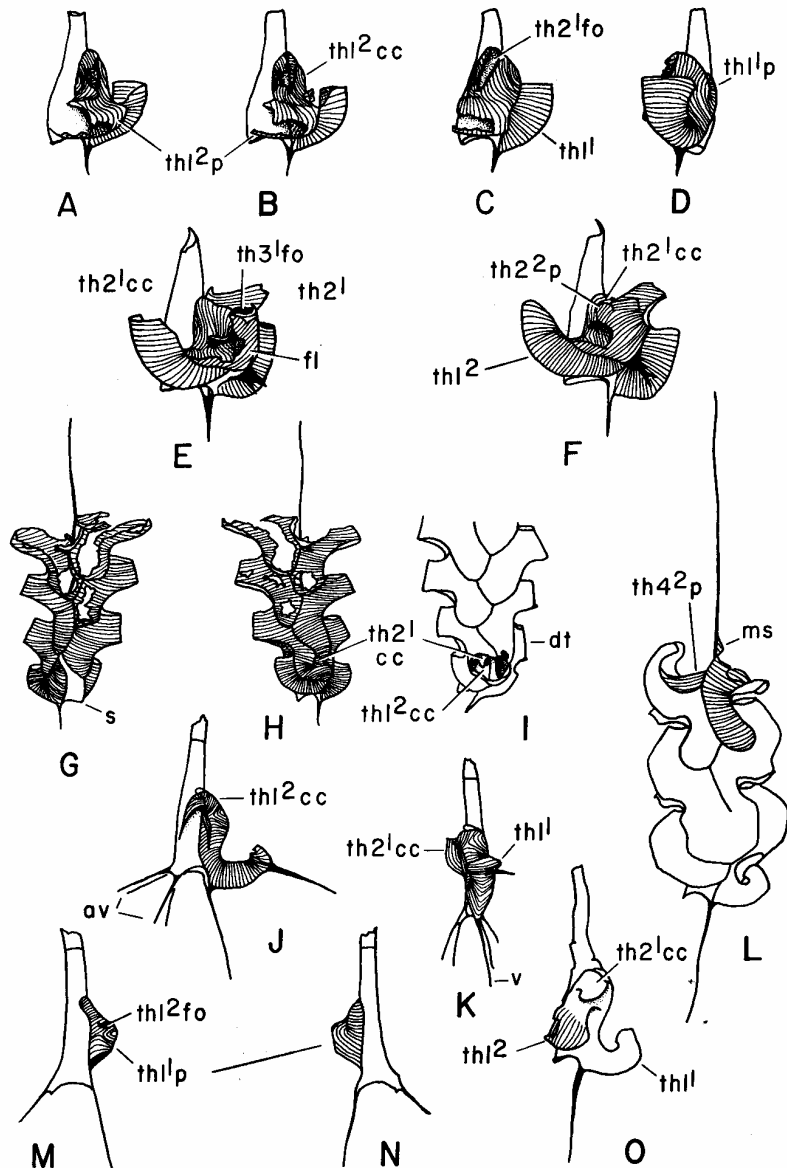

TEXT-FIG. 4. Camera lucida drawings of species exhibiting Pattern C primordial astogeny. See text-fig. 2 for explanation of abbreviations and specimen repositories.

A-F, *Pseudoclimacograptus* (*Archiclimacograptus* subgen. nov.) *eurystoma* Jaanusson, Folkeslunda Limestone, Lasnamägi Stage ('*G.* *teretiusculus* Zone?'), Gärdslösa, Öland. A-D, Cn 59921, oblique right-lateral, reverse, oblique reverse, and left-lateral views, respectively, showing construction of right-handed crossing canal of $th2^1$ and its origin from $th1^2$, $\times 27$. E, F, Cn 59922, oblique reverse and reverse views; note final hood-like form of crossing canal of $th2^1$ and origin of $th2^2$ and $th3^1$, $\times 27$.

G-I, *Prolasiograptus haplus* (Jaanusson), Folkeslunda Limestone, Lasnamägi Stage ('*G.* *teretiusculus* Zone?'), Gärdslösa, Öland. G, H, Cn 59925, obverse and reverse views; note exposed patch of crossing canal of $th2^1$ in

and 2c is shown, incorrectly, as left-handed). This morphology appears to be distinctive of species with Pattern C primordial astogeny.

Species exhibiting Pattern C commonly possess a zigzag median septum, but it may become straight (or nearly so) after the first few thecae, as in '*C.*' *distichus* (Eichwald) (Bulman 1932, pl. 4, figs. 24 and 25) or '*A.*' *munimentus* Berry (1964, pl. 14, text-figs. 1-4). The proximal end of rhabdosomes exhibiting Pattern C is evenly rounded to blunt and generally broad. In obverse view the sicula is exposed only to the level of the aperture of $th1^1$ or $th1^2$. Sharply geniculate thecae predominate in this species group.

Pattern D (text-figs. 5, 6, 7A-C)

The sicula in this group is rather broad for its length, and its axis is usually strongly deflected toward the dorsal side of the sicula. The aperture bears only a virgella. The metasacula commonly exhibits a series of dense, raised bands comprising two or three condensed fuselli (text-fig. 6O, N). The prosacula is usually absent and is replaced by one or two stout rods that merge with the virgula. $Th1^1$ is small and possesses a tightly upturned metatheca that grows closely adpressed to its protheca. $Th1^2$ is prosoblastic and bifurcates shortly after crossing $th1^1$, giving rise to $th2^1$ from its right side, as in Pattern C (text-fig. 5C-E). The crossing canals of both $th1^2$ and $th2^1$ grow across the sicula in a nearly horizontal direction. The crossing canal of $th2^1$ ceases growth near the sicular axis and exhibits a hood-like form. The flange, that in Patterns A and C had grown upward from near the sicular aperture to fuse with the approaching edge of the crossing canal of $th2^1$, appears in Pattern D on the dorsal side of the crossing canal of $th1^2$ (text-figs. 5M and 6G). As the flange grows upward it is linked to the hood of $th2^1$ by a list (text-figs. 5J, 6L, 7B). This event marks the differentiation of the prothecae of $th2^1$ and $th2^2$. There are four primordial thecae and two crossing canals ($th1^2$ and $th2^1$). $Th2^2$ or some later theca is dicalycal. The median septum may be zigzagged, may become straight distally, or may be straight throughout (as in *C. bicornis*) among species known to possess this astogenetic pattern. The proximal end of these species is narrow and evenly rounded. In obverse view the sicula is exposed only to the level of the aperture of $th1^1$ or $th1^2$. Post-primordial thecae range in shape from pseudoclimacograptid to climacograptid.

Pattern E (text-fig. 7D-L)

The sicula is like that described for Pattern D. The long virgella is angled across the sicular aperture. The metatheca of $th1^1$ is tightly upturned and adpressed against its protheca. The hood over the foramen of $th1^2$ is completely enclosed by the metatheca of $th1^1$. The crossing canal of $th1^2$ originates as an isolated flange located on $th1^1$ below the foramen of $th1^2$ (text-fig. 7H, J). From this origin, it grows upward diagonally across the sicula with no downward component of growth. $Th2^1$ arises from $th1^2$ above a prominent growth-line unconformity by a pattern of differentiation like that seen in the budding of distal thecae (text-fig. 7I, K). Accordingly, there are two primordial thecae and one crossing canal ($th1^2$).

Rhabdosomes of species with this astogenetic pattern may be septate, with a straight median septum and $th2^2$ or some later theca dicalycal, or they may be aseptate. The proximal end is narrow

region between $th1^1$ and $th1^2$ in reverse aspect, $\times 14$. I, Cn 59962, reverse view, proximal end broken to reveal internal right-handed origin of crossing canal of $th2^1$, $\times 14$.

J, K, M, N, *Dicaulograptus hystrix* (Bulman), Folkeslunda Limestone, Lasnamägi Stage ('*G.*' *teretiusculus* Zone?), Gärdslösa, Öland, $\times 27$. J, K, Cn 59928, reverse and left-lateral views; note disconformable crossing of left-lateral wall of $th1^2$ by newly differentiated, right-handed crossing canal of $th2^1$. M, N, Cn 59927, reverse and obverse views.

L, O, *Pseudoclimacograptus* (*Archiclimacograptus* subgen. nov.) *luperus* Jaanusson, Folkeslunda Limestone, Lasnamägi Stage ('*G.*' *teretiusculus* Zone?). L, Cn 54587, Gärdslösa, Öland, reverse view of holotype; note early origin of $th3^1$ and extensive exposure of crossing canal of $th1^2$. O, Cn 59929, Lerkaka, Öland, reverse view, early $th2^1$ growth stage with right-handed origin of $th2^1$ and broken metatheca of $th1^2$. Both $\times 27$.

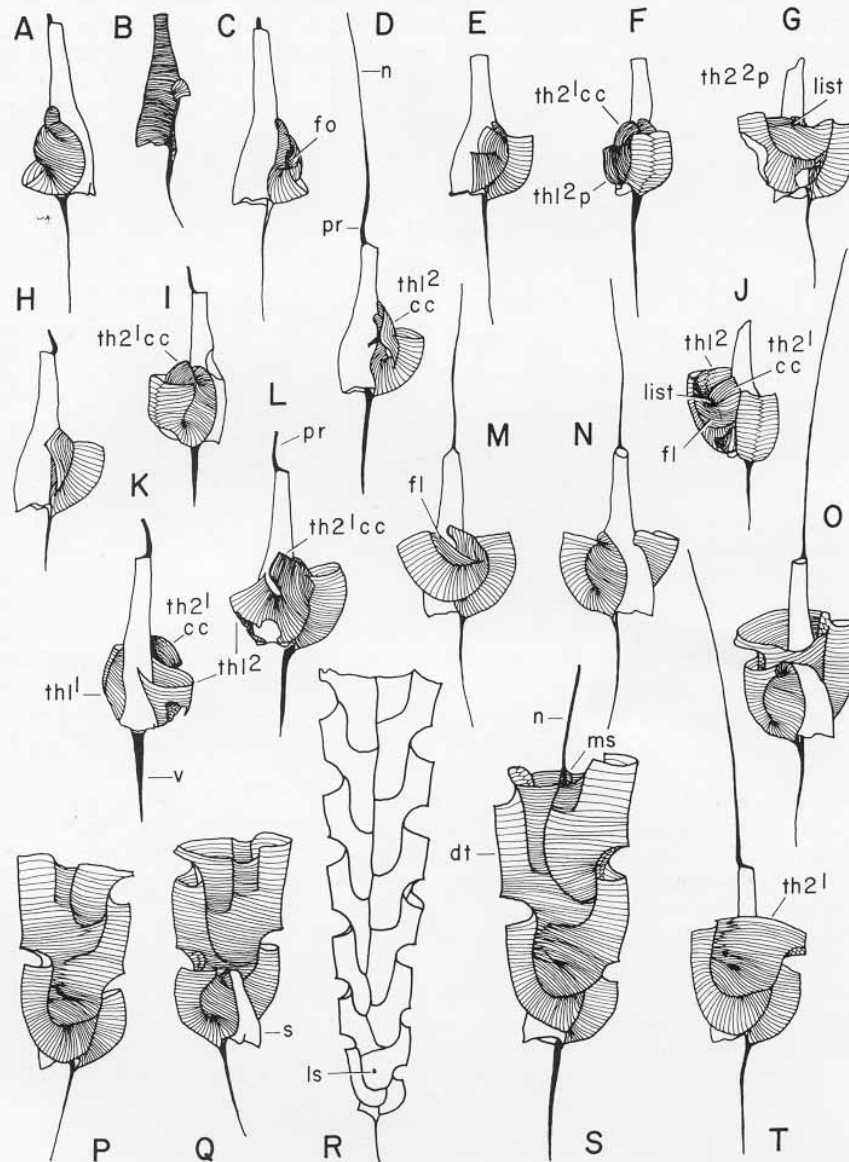

TEXT-FIG. 5. Camera lucida drawings illustrating Pattern D primordial astogeny in *Climacograptus* (*Climacograptus*) sp. cf. *C. (C.) caudatus* Lapworth; Viola Springs Formation (101 m above base of section H; Alberstadt 1973), Maysvillian Stage (*C. pygmaeus* Zone), Arbuckle Mtns., Oklahoma. All illustrations are reverse views unless noted otherwise. See text-fig. 2 for explanation of abbreviations and specimen repositories.

A, c, MCZ 9463/1, obverse and reverse views; note prosoblastic form of $th1^2$. B, MCZ 9463/2. D, MCZ 9463/3; note list linking crossing canal of $th1^2$ with sicula and marking differentiation of right-handed $th2^1$. E, F, MCZ 9463/4, reverse and left-lateral view of later stage in growth of crossing canal of $th2^1$. G, J, MCZ 9463/5, reverse and left-lateral views of early $th2^2$ stage; list links upward-growing flange of protheca of $th2^1$ with hood-like crossing canal. H, I, MCZ 9463/6, reverse and oblique left-lateral views. K, L, MCZ 9463/7,

and unevenly rounded to somewhat rectangular. The markedly offset sicula lies almost entirely to the right of the plane of symmetry in obverse view and is exposed to the level of the aperture of $th1^2$ (text-fig. 7L). Post-primordial thecae are sharply geniculate, climacograptid thecae with nearly vertical supragenicular walls.

Pattern F (text-fig. 8)

The sicula is slender and bears a prominent pair of antivirgellar spines in addition to the usual virgella. The metatheca of $th1^1$ is tightly recurved and grows upward along its protheca. $Th1^2$ is prosoblastic and the hood which covers the foramen of $th1^2$ is generally short and largely or entirely enclosed by $th1^1$ (text-fig. 8D, J, M). The crossing canal of $th1^2$ arises as an isolated flange on $th1^1$ below the foramen (text-fig. 8E, J), as in Pattern E. It subsequently grows diagonally upward across the sicula. Near the mid-line of the sicula, this upward-growing flange bifurcates to produce both the metatheca of $th1^2$ and the protheca of $th2^1$ (text-fig. 8H, N). $Th2^2$ arises by a pattern of differentiation that is like that of all subsequent thecae (text-fig. 8H). There are three primordial thecae and one crossing canal ($th1^2$).

Pattern F rhabdosomes are aseptate. The proximal end is strongly asymmetrical and generally quite narrow compared to the distal width of the colony. In obverse view the sicula is exposed for a large part of its length, nearly to the level of the aperture of $th2^1$. Post-primordial thecae range from climacograptid with prominent genicular flanges to glyptograptid or nearly orthograptid.

Pattern G (text-figs. 9 and 10)

The sicula is long and slender with a virgella and a pair of antivirgellar spines on the sicular aperture. $Th1^1$ gives rise to a prosoblastic $th1^2$. The crossing canal of $th1^2$ grows diagonally downward across the sicula in the form of a hood that is free on its ventral (proximal-ward) side (text-figs. 9A and 10A). It fuses with an upward-growing, wedge-shaped flange that arises partly on the sicula and partly on $th1^1$ near the sicular aperture. The hood of $th1^2$ continues to grow downward but now as a complete tube (text-figs. 9D and 10C, E). The edge of the open ventral margin of the earlier hood of $th1^2$ bears a thickened rim and, together with one edge of the upward-growing flange, forms a foramen from which $th2^1$ develops (text-fig. 9B). Thus, $th1^2$ and $th2^1$ form a somewhat asymmetrical pair with a smooth arch connecting their prothecae across the reverse side of the sicula. The protheca of $th2^1$ expands rapidly, growing upward along the dorsal wall of the crossing canal of $th1^2$ (text-fig. 9E, F). $Th2^2$ differentiates from the prothecae of $th2^1$ above a growth line unconformity, in a fashion like that by which all subsequent thecae arise (text-figs. 9G and 10D). There are three primordial thecae and one crossing canal ($th1^2$).

The first several thecal pairs alternate, and the dicalycal theca may be $th3^1$ or, more commonly, some later theca. Many species exhibiting Pattern G are aseptate. Septate species have a straight median septum. The proximal end is tapered bluntly and markedly asymmetric. On the obverse side of the colony the sicula is visible for most of its length, up to a level near the aperture of $th2^1$, as in Pattern F. Post-primordial thecae range from orthograptid to amplexograptid or lasiograptid in shape.

right-lateral and reverse views, showing relation of mature hood-like crossing canal of $th2^1$ to sicula and $th1^2$. M, N, MCZ 9463/8, reverse and obverse views; note upward-growing flange along dorsal side of $th1^2$. O, T, MCZ 9463/9, reverse and obverse views; note intercalation of short fuselli into reverse lateral wall of protheca of $th2^1$ in the region from which $th2^2$ will soon appear (cf. text-fig. 5P, S). P, Q, MCZ 9463/10, reverse and obverse views, illustrating origin of $th2^2$ by simple distal differentiation from protheca of $th2^1$. R, MCZ 9463/11, sicula with slight secondary elongation; note proximally zig-zag septum and dimple-like list scar (ls) corresponding to list shown in text-fig. 5J (cf. text-figs. 6I, L and 7B), $\times 14$. S, MCZ 9463/12.

All except R $\times 25$.

Pattern H (text-figs. 3F-H, K, L, 11, 12K-O)

The sicula is commonly relatively short and broad (about 1 mm or less in length among many Ordovician representatives), but varies greatly (e.g. *Cystograptus penna*). The sicular aperture bears only a virgella. However, the dorsal margin is often prolonged and somewhat incurvate. The metatheca of $th1^1$ is generally sharply upturned, as in Patterns E and F, and may partially enclose its protheca on the obverse side. It also encloses the foramen and small hood of $th1^2$ on its reverse side. In many species with this pattern (but not '*Climacograptus kuckersianus* Wiman'), the reverse wall of the metatheca of $th1^1$ is free and is not anchored against either the sicula or the protheca of $th1^1$ (text-fig. 3F). The crossing canal of $th1^2$ begins as an isolated flange located on $th1^1$ near the sicular aperture. As it grows diagonally upward, across the sicula, its ventral edge grows along the edge of the reverse wall of $th1^1$. Early in the growth of the protheca of $th1^2$, $th2^1$ begins to differentiate—a process marked by the interfingering of wedge-shaped fuselli in the region adjacent to $th1^1$ (text-figs. 11H, I and 12K). $Th2^2$ differentiates in a fashion like that of later thecae (text-figs. 3H, 11M, 12K). There are three primordial thecae and one crossing canal ($th1^2$). Rhabdosomes are usually septate with the dicalycal theca at the primitive location ($th2^1$) or later. The majority of Pattern H species exhibit a straight median septum, but among some Silurian species (e.g. *Clinoclimacograptus retroversus* and *Metaclimacograptus undulatus*) the median septum is undulate to zigzagged.

The proximal end is quite narrow and sharply rounded or fusiform and strongly asymmetrical. In obverse view, $th1^2$ partly encloses the sicula, which is exposed only up to the level of the aperture of $th1^1$ or, at most, nearly up to the level of the aperture of $th1^2$ (text-figs. 3H, L, and 11J, L). Among Ordovician Pattern H species, post-primordial thecae are restricted to glyptograptid and climacograptid in shape. The rhabdosomes tend to be narrow and parallel sided with little distal widening. However, Silurian species encompass a broad range of diplograptinid thecal shapes and colony forms.

Pattern I (text-fig. 12A-J)

The long sicula bears only a virgella projecting from its simple aperture. $Th1^1$ arises relatively close to the sicular aperture and has an exceptionally short descending segment. The foramen of $th1^2$ in the right lateral wall of the protheca of $th1^1$ bears only a minute hood, or no hood at all. $Th1^1$ turns upward very sharply, and grows upward with its left lateral wall partly or completely enclosing its descending protheca in obverse aspect (text-fig. 12C, H). As $th1^1$ grows, its right lateral wall begins to sweep out on to the metasicula and to enclose the latter's reverse side (text-fig. 12A, B, D). After this wall crosses the sicula's mid-line and the theca approaches its mature length, an interthecal septum appears that divides the right lateral wall into a metatheca of $th1^1$ and a protheca of $th1^2$ (text-fig. 12A, D). A growth line unconformity may also mark the separation of the protheca of $th1^2$.



of $th2^1$. H, I, MCZ 9464/7, obverse and reverse views; dicalycal $th2^2$ arises by simple differentiation from distal portion of protheca of $th2^1$.

J-P, *Climacograptus (Climacograptus) bicornis* (Hall), Viola Springs Formation (0.3 m above base of section D; Alberstadt 1973), Rocklandian Stage (upper *C. bicornis* Zone), Arbuckle Mtns., Oklahoma. J, MCZ 9465/1, showing paired prosicular rods, raised fusellar ridges on metasicula, and origin of $th2^2$ near aperture of hood-like crossing canal of $th2^1$ (cf. text-figs. 6L and 7A). K, MCZ 9465/2. L, MCZ 9465/4, proximal end of rhabdosome with portion of reverse side broken away, revealing hood-like crossing canal of $th2^1$ and list that linked crossing canal with reverse wall of protheca of $th2^1$ (cf. text-figs. 5J and 6G). M, N, MCZ 9465/5, ventral and reverse views of immature metasicula, showing dorsal deflection and concave ventral side; note regularly spaced fusellar rings and paired prosicular rods. O, MCZ 9465/3. P, MCZ 9465/6, early growth stage showing prosoblastic $th1^2$.

All $\times 35$.

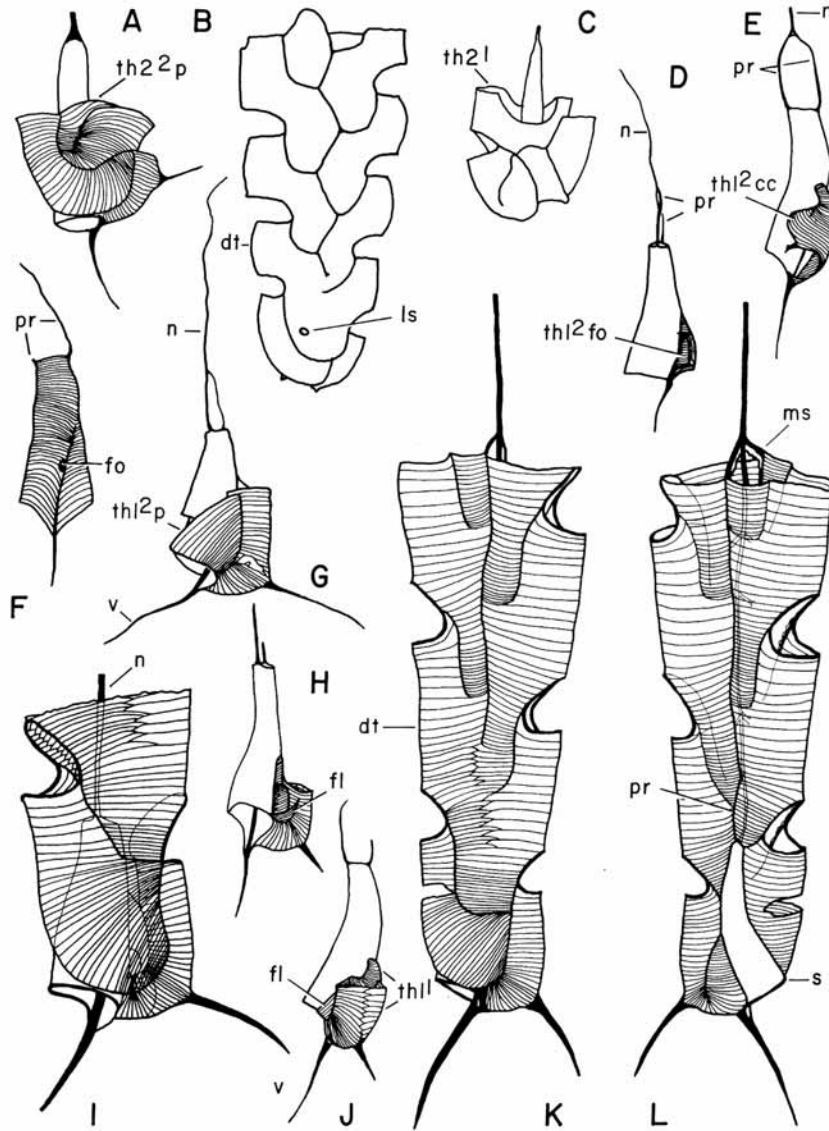

TEXT-FIG. 7. Camera lucida drawings of species exhibiting Pattern D and Pattern E primordial astogenies. All illustrations are reverse views unless noted otherwise. See text-fig. 2 for explanation of abbreviations and specimen repositories.

A, *Pseudoclimacograptus (Pseudoclimacograptus) scharenbergi* (Lapworth), BMNH GS 74247, Balclatchi beds, Caradoc Series (*D. multidentis* Zone), Laggan Burn, Ayrshire, Scotland; note origin of $th2^2$ at point of fusion between upward-growing flange of reverse prothecal wall and crossing canal of $th2^1$; sicular apex sealed but lacking normal prosicula.

B, C, *P. (P.) clevensis* Skoglund, Fjäckå Shale, Jonstorp, Västergötland. B, Vg 757, semi-relief specimen with prominent list scar (ls) where list that links crossing canal of $th2^1$ to reverse prothecal wall has been pressed through. C, Vg 758, obverse view; $th2^1$ rapidly encloses strongly deflected sicula.

Following its origin, $th1^2$ continues the trend of the right lateral wall of $th1^1$ and grows strongly upward, often reaching the dorsal side of the sicula well above the latter's aperture. This origin of $th1^2$ is quite late (in some species it does not appear until after the protheca of $th1^1$ has reached the dorsal side of the sicula) compared to other diplograptinid astogenetic patterns. The differentiation of $th1^2$ follows a developmental pattern like that of all later thecae. Thus, Pattern I exhibits only one primordial theca and no crossing canals. Although generally aseptate, some Pattern I species have a straight median septum and a dicalycal $th2^1$ or some later theca. In at least some dimorphograptids (e.g. *Rhaphidograptus toernquisti*) the metatheca of $th1^2$ appears to be suppressed (text-fig. 12D) but $th2^1$ develops from the protheca of $th1^2$ in the normal fashion.

The proximal end is sharply fusiform to acicular. In reverse aspect, a substantial portion of the dorsal side of the sicula is visible. The combined right lateral wall of $th1^1$ and ventral wall of $th1^2$ often have a concave curvature (especially in species with orthograptid or petalograptid colonies). In obverse view the sicula is commonly exposed for most or all of its length. Nevertheless, thecae are sufficiently elongate that it is usually enclosed by the level of the aperture of $th1^1$ or, more rarely, by a level slightly below that of the aperture of $th1^2$. Also in obverse view, $th1^1$ often appears to grow directly upward from near the sicular aperture because of its enclosure of the short descending portion of the protheca of $th1^1$. Pattern I species (all are Silurian in age) possess post-primordial thecae ranging in shape from climacograptid to orthograptid and petalograptid.

PHYLOGENY AND CLASSIFICATION OF THE DIPLOGRAPTACEA

Suborder VIRGELLINA Fortey and Cooper, 1986

Diagnosis. Graptoloids with a virgella. Primordial astogeny is of isograptid type or modified to 'diplograptid', 'nemagraptid', or 'monograptid' type. Rhabdosomes extensiform to reclined or platycalycal scandent.

Superfamily DIPLOGRAPTACEA Lapworth, 1873, emend.

Diagnosis. Horizontal to reclined and partly to wholly scandent, dipleural biserial and monoserial virgellinids with a single dicalycal theca, delayed to $th2^1$ or some later theca, and three crossing canals; $th1^1$ with metasicular origin and $th1^2$ arising right-handedly from $th1^1$.

Discussion. Text-fig. 13 depicts the cladistic relationships among the major diplograptacean taxa (typified in the diagram by their astogenetic patterns), the stem group *Oelandograptus* gen. nov. ('Ol',—see below), and the other taxa of the Virgellina Fortey and Cooper, 1986. The Phyllograptidae, which possess an isograptid primordial astogeny (denoted by 'Is' in text-fig. 13), form a convenient outgroup for comparisons among the Diplograptacea (see Cooper and Fortey 1983 for a discussion of the primitive status of this astogenetic pattern).

D-L, *Climacograptus* (*Diplacanthograptus* subgen. nov.) *spiniferus* Ruedemann, Viola Springs Formation, Maysvillian Stage ('*C.* *pygmaeus* Zone), Arbuckle Mtns., Oklahoma; MCZ 9466 from 51 m above base of section along Interstate Highway 35, adjacent to section H; MCZ 9467 from 104.5 m above base of section H; MCZ 9468 from 76.5 m above base of section J; MCZ 9469 from 30.5 m above base of section H (Alberstadt 1973). D, MCZ 9466/1, early $th1^1$ stage; note set of prosicular rods in place of normal prosicula and dorsal deflection of metasicula. E, MCZ 9467/1, ventral view; note stirrup-like form of prosicular rods and prosoblastic crossing canal of $th1^2$. F, MCZ 9466/2, ventral view; note characteristic twisted, asymmetric form of sicula, $\times 40$. G, MCZ 9468/1, $th1^2$ formed by upward-growing flange. H, J, MCZ 9466/3, oblique reverse and left-lateral views; flange of $th1^2$ originates on reverse lateral wall of $th1^1$, not in continuity with earlier segment of its crossing canal. I, MCZ 9469/1; note origin of $th2^1$ by simple differentiation from distal portion of protheca of $th1^2$, $\times 40$. K, L, MCZ 9467/2, reverse and obverse views; note dicalycal $th2^2$ and strongly deflected sicula visible for its entire length on obverse side.

All except F and I $\times 32$.

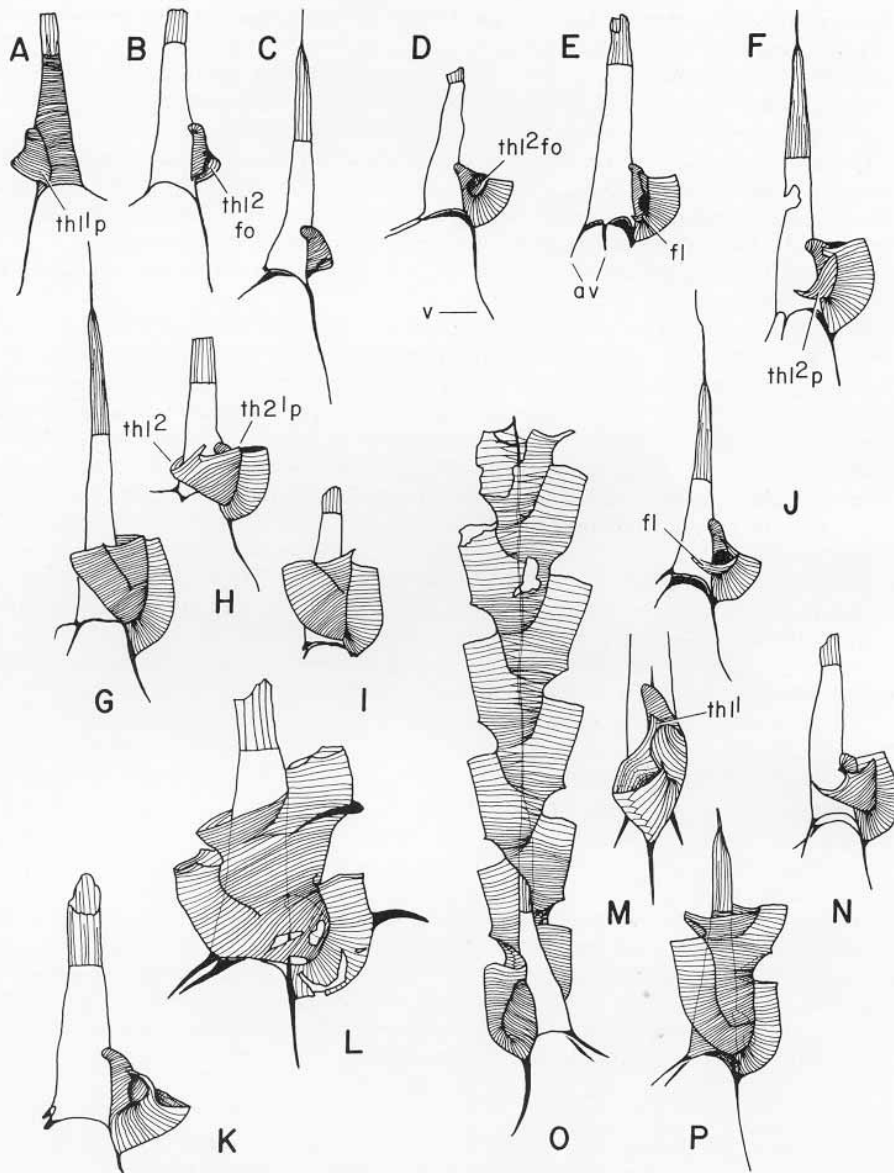

TEXT-FIG. 8. Camera lucida drawings of species exhibiting Pattern F primordial astogeny. All illustrations are reverse views unless noted otherwise. See text-fig. 2 for explanation of abbreviations and specimen repositories.

A-D, H-J, O, P, *Geniculograptus* (gen. nov.) *pygmaeus* (Ruedemann), Viola Springs Formation, Maysvillian Stage ('C.' *pygmaeus* Zone), Arbuckle Mtns., Oklahoma; MCZ 9427 from 51 m above base of section along Interstate Highway 35, adjacent to section H and MCZ 9470 from 104.5 m above base of section H (Alberstadt 1973). A, B, MCZ 9470/1, obverse and reverse views of specimen in early phase of formation of foramen of $th1^2$. C, MCZ 9470/2. D, MCZ 9427/4, completed foramen of $th1^2$ and metatheca of $th1^1$ nearing maturity. H, MCZ 9427/2, early $th2^1$ stage showing division of crossing canal of $th1^2$ to form metatheca of $th1^2$ and protheca of $th2^1$. I, MCZ 9427/1. J, MCZ 9427/3, stage showing construction of protheca of $th1^2$ by upward-

The cladistic relationships depicted in text-fig. 13 provide an outline of the branching history of the group. It includes three alternative interpretations, differing in their treatment of the Dicranograptinae and the Nemagraptinae. The basis for these alternatives is discussed below. As is readily apparent from the cladograms (and as Bulman had suspected in 1963*a, b*), the Diplograptacea comprises three large primary divisions: the Diplograptidae, the Monograptidae, and the Orthograptidae. The roots of these families lie deep within the early history of the clade. Each family exhibits a striking degree of parallelism during its evolutionary history and each includes a subgroup that is characterized by a highly derived and *highly simplified* astogenetic pattern that becomes dominant among the family's representatives in Upper Ordovician or Silurian faunas. The highly derived uniseriate monograptines also belong taxonomically among the Diplograptacea, as do the Dicranograptidae (see below).

Previously, when most graptolithologists considered the Monograptina to be a grade of organization that stood above that of the Diplograptina (one which was achieved repeatedly by several lineages), the ranking of these two taxa at the same level was appropriate (see Rigby 1986). However, the monograptid condition is a synapomorphy that characterizes a subclade of the Diplograptacea and is not a grade of organization. The close structural and cladistic relationships between the traditional Monograptina and their antecedents among the dimorphograptines and glyptograptines (discussed below in the section 'Monograptidae') indicate that there is no longer sufficient justification for the retention of the high taxonomic rank usually accorded to this subclade. Instead, I propose here a classification that emphasizes their evolutionary derivation from among the diplograptaceans. In as much as the ICZN has extended the principle of priority to encompass family group taxa, the entire family to which the monograptines belong must take the most senior available name—the Monograptidae. The Monograptidae, thus, includes Arenig biserial species as well as the traditional Silurian and Devonian monograptine and cyrtograptine species.

It is very difficult to establish a well-corroborated hierarchical branching among the three original families. Archaic monograptids (e.g. '*Glyptograptus*' *dentatus*, with a Pattern B astogeny) and archaic diplograptids (in the form of *Pseudoclimacograptus cumbrensis* and related forms, with a Pattern C astogeny) each differ from the primitive diplograptaceans (Pattern A representatives of the '*G.*' *astrodentatus* species group, herein recognized as *Oelandograptus* gen. nov.) in a unique suite of derived characters. All astogenetic similarities that they exhibit with Pattern A are symplesiomorphic, regardless of the cladistic position of the Dicranograptidae relative to other diplograptaceans. However, data on the character of the thecal apertures among these graptolites appear to be helpful. Very early in the history of the Orthograptidae, this group acquired a cusped thecal aperture (text-fig. 2L, M). An identical thecal form is present in '*G.*' *dentatus* (text-fig. 3i) and '*G.*' *cernus* and suggests that the Orthograptidae (excluding the stem group *Oelandograptus* gen. nov.) and the Monograptidae are sister groups, and that the Diplograptidae branched from the stem group lineage prior to the appearance of this thecal form and the separation of the Monograptidae and Orthograptidae. Given the small size of the group and their paraphyletic status, the members

growing flange; internal portion of crossing canal enclosed by th¹. o, MCZ 9470/3, obverse view showing extensive exposure of sicula and alternating thecae. p, MCZ 9470/4.

E, F, G, N, *G.* (gen. nov.) *typicalis* (Hall), Viola Springs Formation, 51 m above base of section along Interstate Highway 35, adjacent to section H (Alberstadt 1973), Maysvillian Stage ('*C.*' *pygmaeus* Zone), Arbuckle Mtns., Oklahoma. E, MCZ 9426/4, incipient flange of th¹. F, MCZ 9426/3. G, MCZ 9426/1, early th² stage showing paired growth of protheca of th² and metatheca of th¹. N, MCZ 9426/2; note division of protheca of th¹ to form its metatheca and descendant protheca of th².

K, L, M, *G.* (gen. nov.) *inuiti* (Cox), Maysvillian Stage ('*C.*' *manitoulinensis* Zone), Ungava Bay, Akpatok Island, Canada. K, M, SM unnumbered (Cox Collection), reverse and left-lateral views showing internal portion of crossing canal of th¹ enclosed by reverse lateral wall of metatheca of th¹, × 32. L, SM A.102372, showing reverse lateral wall of protheca of th¹ formed by simple upward-growing flange.

All except K and M × 26.

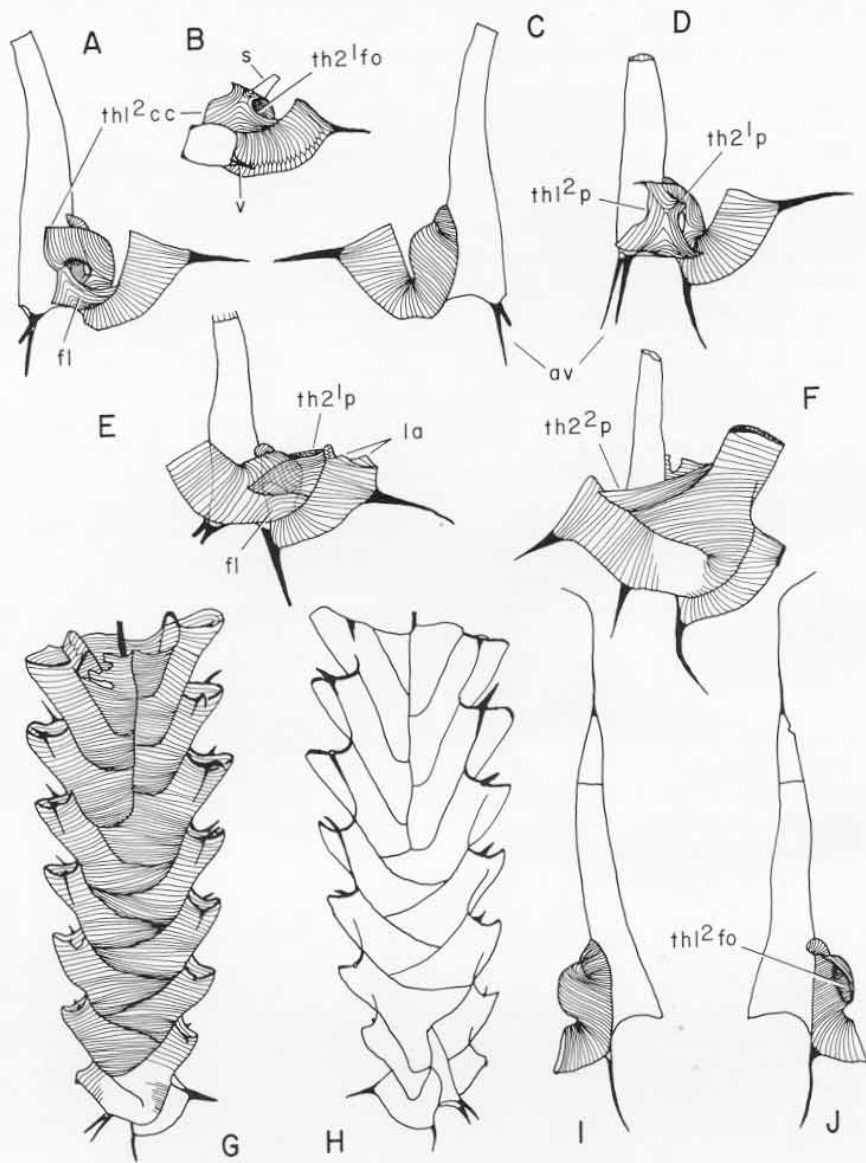

TEXT-FIG. 9. Camera lucida drawings of species exhibiting Pattern G primordial astogeny. All illustrations are reverse views unless noted otherwise. See text-fig. 2 for explanation of abbreviations and specimen repositories.

A-D, F-H, *Orthograptus quadrimucronatus* (Hall), ssp. Viola Springs Formation (51 m above base of section along Interstate Highway 35, adjacent to section H; Alberstadt 1973), Maysvillian Stage ('C.' *pygmaeus* Zone), Arbuckle Mtns., Oklahoma. A, c, MCZ 9471/1, reverse and obverse views; note fusion of hood with upward-growing flange of prosoblastic crossing canal of $th1^2$. B, MCZ 9471/2, proximal view illustrating origin of flange of $th1^2$. D, MCZ 9471/3; note paired growth of $th1^2$ and $th2^1$ following fusion of hood and flange. F, MCZ 9471/4, $th2^2$ arises from distal portion of protheca of $th2^1$ by simple differentiation. G, H, MCZ 9471/5, reverse and obverse views; note extensively exposed sicula and delayed dicalyca theca, $\times 12$.

E, *Amplexograptus leptotheca* (Bulman), SM A.723040, Balclatchie beds, Caradoc Series ('D.' *multidens* Zone), Laggan Burn, Ayrshire, Scotland; showing presence of upward-growing flange in ontogeny of $th1^2$; also note growth of protheca of $th2^1$ back upon crossing canal of $th1^2$.

I, J, *A. bekkeri* (Opik), Cn 59938, Kukruse Stage, (*N. gracilis* Zone), Estonia; formation of prosoblastic $th1^2$.

All except G and H $\times 26$.

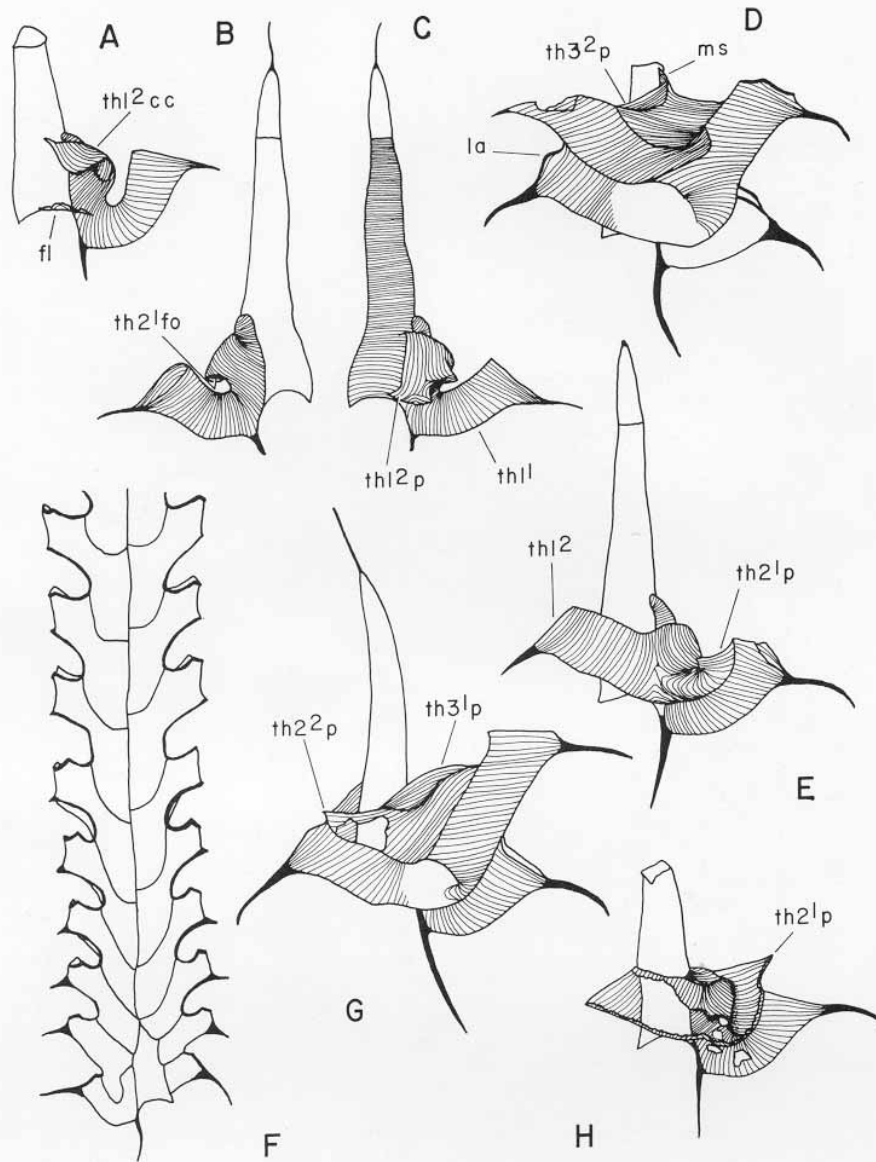

TEXT-FIG. 10. Camera lucida drawings illustrating Pattern G primordial astogeny in *Amplexograptus bekkeri* (Opik); Kukruse Stage (*N. gracilis* Zone), Estonia (Holm Collection). All illustrations are reverse views unless noted otherwise. See text-fig. 2 for explanation of abbreviations and specimen repository.

A, Cn 59909; note upward growing flange. B, C, Cn 59939, obverse and reverse views, showing fusion of hood-like crossing canal with small flange and early growth of protheca of $th2^1$. D, Cn 59942. E, Cn 59943; note origin of $th2^1$ still in early prothecal stage, while $th1^2$ nearly complete. F, Cn 2474c, obverse view; note strong gradient in thecal form from orthograptid through lasiograptid to amplexograptid in distal thecae, $\times 12$. G, Cn 59941; note post-primordial pattern of differentiation in $th2^2$ and $th3^1$. H, Cn 59940, broken specimen showing course of internal canals.

All except F $\times 26$.

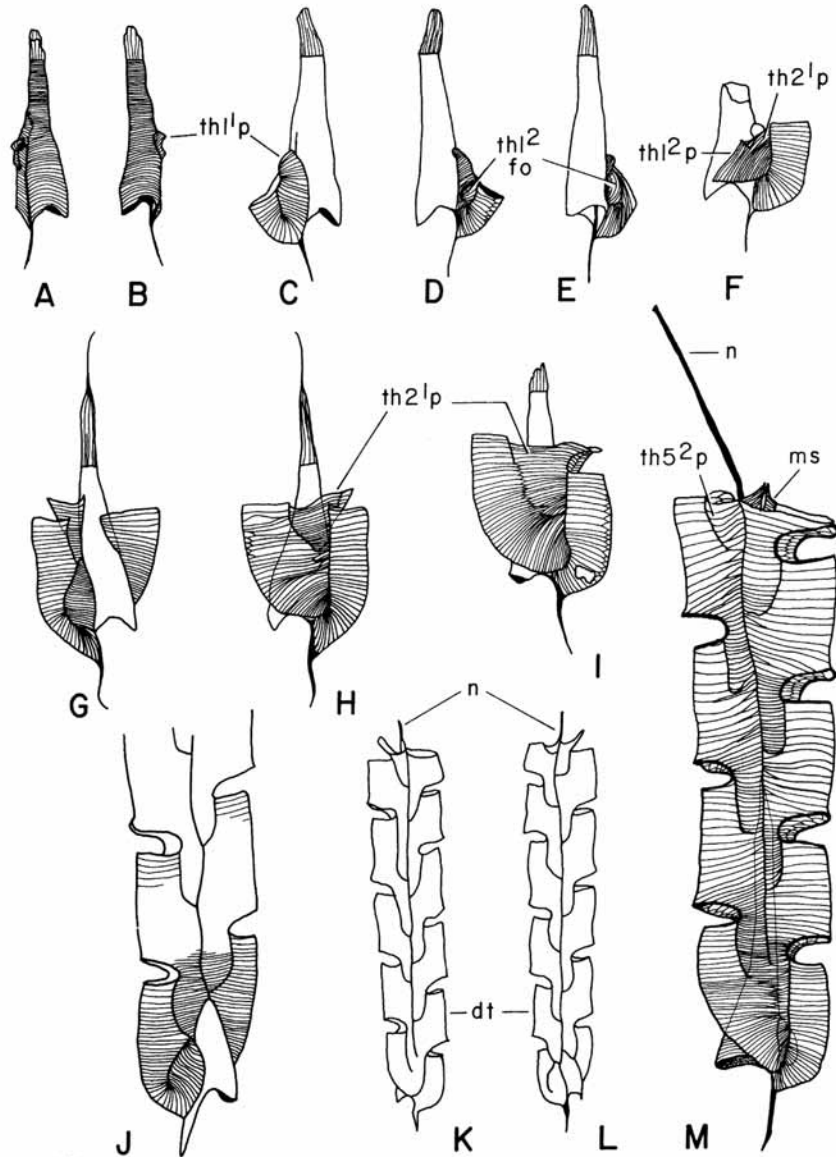

TEXT-FIG. 11. Camera lucida drawings illustrating Pattern H primordial astogeny in *Glyptograptus kuckersi anus* (Wiman); Kukruse Stage (*N. gracilis* Zone), Estonia (Holm Collection). All illustrations are reverse view: unless noted otherwise. See text-fig. 2 for explanation of abbreviations and specimen repository.

A, B, Cn 59933, ventral and reverse views; note form of sicular aperture. C-E, Cn 59930, obverse, reverse and oblique dorsal views, illustrating enclosure of foramen of $th1^2$ by the metatheca of $th1^1$. F, Cn 59931 crossing canal of $th1^2$ formed by upward growing flange. G, H, Cn 59932, obverse and reverse views; note origin of protheca of $th2^1$ by zigzag suturing of fuselli below interthecal septum. I, Cn 59934. J, Cn 54606 obverse view; note rapid enclosure of sicula by level of aperture of $th1^1$. K, L, Cn 59935, reverse and obverse views, $\times 12$. M, Cn 59936, bleached specimen showing details of dicalycal budding and distal thecal ontogenies

All except K and L $\times 26$.

of the *Oelandograptus* gen. nov. *austrodentatus* species group are treated as *Incertae familiae* within the classification presented here.

Family DICRANOGRAPTIDAE Lapworth, 1873, emend. Fortey and Cooper, 1986

Diagnosis. Diplograptaceans with uniserial and uni-biserial, partly scandent to reclined or extensiform rhabdosomes with three crossing canals and dicalycal $th2^1$; sicula with aperture notched on dorsal side and with paired clefts adjacent to the lanceolate virgella; thecae exhibit strong morphological gradient along stipes, with proximal-most thecae at least having isolate, introverted apertural regions; all thecae with sharp fusellar disconformity within the prothecal segment (see Finney 1985).

Discussion. Among the traditional Diplograptina, the Dicranograptidae, and in *Nemagraptus* (see Finney 1985), the first dicalycal theca is delayed from its primitive position at $th1^2$ to a position at $th2^1$ or later, producing three crossing canals. Unlike *Phyllograptus* and the multi-stiped dichograptids, no further dicalycal thecae occur in any of these taxa. As Finney (1985) has shown, the lateral branches of *Nemagraptus* are cladia and are produced in a quite different way from the branch dichotomies of the anisograptids and dichograptids. The possession of a delayed single dicalycal theca distinguishes the advanced Virgellina from all previous Graptoloidea. An additional synapomorphy is the metasicular origin of $th1^1$.

Nemagraptus shares a unique configuration of the sicular aperture with the Dicranograptidae Lapworth, 1873, emend. Fortey and Cooper, 1986: the sicular aperture bears two broad lappets that are separated from one another on the antivirgellar side of the sicula by a broad notch. These lappets are also separated from the virgella by a pair of clefts that possess a flared lip (see text-fig. 2H, R). This synapomorphic condition is unknown in other Virgellina, including the traditional Diplograptina, and unites the Dicranograptinae and the Nemagraptinae as the Dicranograptidae, emend. However, the relationship of the Dicranograptidae to the rest of the Diplograptacea and its status as a clade or paraclade are problematic. In addition to the dicalycal $th2^1$ mentioned above, the traditional Diplograptina (or 'diplograptids' in the following discussion) and the Dicranograptinae share additional unique astogenetic features—yet these are not shared with *Nemagraptus*: 1, in contrast to the right-handed origin of $th1^2$ from $th1^1$ in the isograptid pattern, this theca arises left-handedly in 'diplograptids' and dicranograptines; and 2, $th1^2$ then follows a convoluted S-shaped course that Bulman referred to as streptoblastic. Despite vague similarities in thecal form or more intriguing similarities in growth direction, no dichograptid or other virgellinid is known to possess these features. The dicranograptines possess a primordial astogeny that, apart from the form of the sicular aperture, is indistinguishable from that of the primitive diplograptaceans—members of the '*G.* *austrodentatus* group (see Bulman 1945, 1947). These similarities (the left-handed origin of $th1^2$ from $th1^1$, and the streptoblastic form of this second theca), together with the dipleural scandent rhabdosome architecture of *Dicranograptus* and the 'diplograptids', may be interpreted in several ways (cf. text-fig. 13A–C).

First, they may be synapomorphies (text-fig. 13B). If so, this indicates that the 'diplograptids', as traditionally construed, and the Dicranograptinae of the Dicranograptidae are sister groups. It further implies that the 'diplograptids' have lost the unique form of the sicular aperture characteristic of the paraclade Dicranograptidae. The clade 'diplograptids' + Dicranograptinae, in turn, shares with the Nemagraptinae the synapomorphies of three crossing canals and a dicalycal $th2^1$. However, as Fortey and Cooper (1986) noted, this cladistic sequence conflicts sharply with the stratigraphic order of appearance of these taxa. The diplograptids precede the earliest dicranograptines or nemagraptines by at least the entire duration of the Llanvirn (Bulman 1960; Finney 1985). Furthermore, Finney has found that the thecae of *Nemagraptus*, like those of the Dicranograptinae, are highly complex with a number of unique features that make them unlikely to be ancestral to the 'diplograptid' thecal structure.

Secondly, the Dicranograptidae as a whole may be a sister group to the 'diplograptids' (text-fig. 13C), but this does not alleviate the problems posed by the stratigraphic record of these graptolites. Furthermore, it requires either that the similarities in proximal end structure and colony architecture

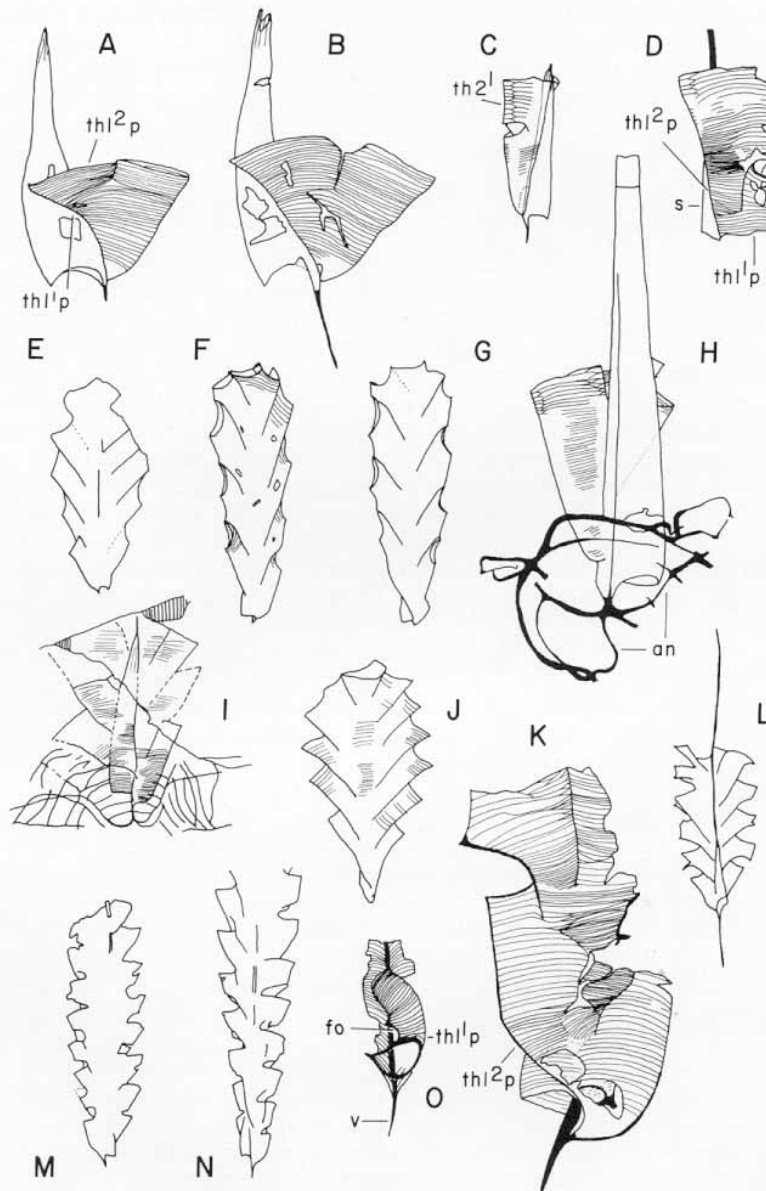

TEXT-FIG. 12. Camera lucida drawings of species exhibiting Pattern H and Pattern I primordial astogenies. See text-fig. 2 for explanation of abbreviations and specimen repositories.

A, B, *Petalograptus* sp. 1, Cn 54917 and Cn 54916, lower Klubbudden Stage (*M. turriculatus* Zone), Dalarna, Sweden; reverse views (after Hutt *et al.* 1970); note metatheca of $th1^1$ in contact with reverse side of sicula; also note pattern of simple differentiation of $th1^2$ from protheca of $th1^1$; dorsal side of sicula extensively exposed, $\times 32$.

C, D, *Rhabidograptus toernquisti* Elles and Wood, Cn 54910 and Cn 54915, upper Bollerup Stage (*M. gregarius* Zone), Dalarna, Sweden; obverse and reverse views (after Hutt *et al.* 1970); note form of $th1^1$ and absence of metatheca of $th1^2$, $\times 12$ and $\times 18$.

between the dicranograptinae and the 'diplograptids' are parallelisms, or that the ostensibly primitive astogenetic and other features of *Nemagraptus* are not primitive but derived.

Thirdly, the Dicranograptidae may be a sister group of the Orthograptidae (text-fig. 13A). In this case the unique dicranograptid sicula form must have been derived from the simple sicula of the 'diplograptids'. In addition to the better fit of this hypothesis with the stratigraphic data, there are two further lines of morphological evidence in its support: 1, several Llanvirn-Llandeilo species among the archaic orthograptids, such as '*G.*' *vikarbyensis* Jaanusson and '*G.*' *teretiusculus sensu* Jaanusson, which exhibit a Pattern A astogeny, have a flared sicular aperture (text-fig. 2L); this flair is strongest on the dorsal side of the sicula and consists of two lobes separated by a broad, shallow notch; this structure may be homologous with the unique lappets and dorsal notch of the dicranograptid sicula; and 2, in *N. gracilis* the first two thecae have isolated, introverted apertures quite like those of *Dicellograptus* (see Finney 1985), while later thecae have simpler apertural regions that are neither isolated nor introverted. If this condition, like the astogenetic pattern, is primitive relative to the condition in *Dicellograptus* (in which all thecae have isolated and introverted apertures), then this complex thecal form must have arisen at the proximal end and spread distally during the course of evolution. This, however, conflicts sharply with the general conservatism of the primordial thecae in virgellinid colonies. Alternatively, if the thecal characters in *N. gracilis* are derived relative to those of early dicellograptids like *D. vagus* Hadding, then the complexity of th¹ and th² may be the result of conservatism in the proximal end while distal thecae became simplified.

Subfamily DICRANOGRAPTINAE Lapworth, 1873, emend. Finney, 1985

Diagnosis. Dicranograptids with Pattern A astogeny; complex introverted, introverted thecae with isolated apertures and lateral apertural processes; reclined uniserial unbranched stipes to uniserial, partly scandent rhabdosomes, at least some of which possess a virgula.

Generic group taxa. *Dicranograptus* Hall, *Dicellograptus* Hopkinson, and *Leptograptus* Lapworth.

E-G, *Petalograptus* sp. 2 (after Hutt *et al.* 1970). E, Trinity College Dublin, TCD 8272A, B, Balbriggan Co., Dublin, Eire (*M. turriculatus* Zone); obverse view; note simple form of sicular aperture, $\times 9$. F, G, Cn 54920 and Cn 54921, lower Klubbudden Stage (*M. turriculatus* Zone), Dalarna, Sweden; reverse views; note narrow, acicular proximal end and short interthecal septum between th¹ and th² (cf. text-fig. 12A), $\times 11$.

H, *P. insectiformis* (Nicholson), Cn 54913, Bollerup Stage (*M. gregarius* Zone), Dalarna, Sweden; obverse view (after Hutt *et al.* 1970); note short downward-growing portion of protheca of th¹ and strongly upward-growing metatheca of th¹; virgella with ancora, $\times 30$.

I, *P. obuti* (Rickards and Koren'), Tchernyshev Central Geol. Mus., Leningrad (topotype collection), Sakmara Formation, Llandovery Series, Mugodjary Range, South Urals, USSR; reverse view (after Rickards and Koren' 1974); note form of th², which arises well above sicular aperture, and growth lines that suggest late differentiation of th², $\times 10$.

J, *P. palmaeus* (Barrande), USNM 161811, Descon Formation, Llandovery Series (*M. gregarius* Zone), south-eastern Alaska; reverse view (after Churkin and Carter 1970), $\times 6$.

K, O, *Glyptograptus* sp. cf. *G. scalaris*, Birmingham University unnumbered, Jupiter Formation, Llandovery Series, south shore Anticosti Island, Quebec. K, (after Barrass 1954) reverse view of proximal end fragment showing origin of th² and probable dicalycal th², $\times 36$. O, ventral view of sicular fragment with protheca of th¹; note absence of distinct crossing canal of th², $\times 36$.

L, *Paraclimacograptus immotatus obesus* (Churkin and Carter), USNM 161611, Descon Formation, Llandovery Series (*M. cyphus* Zone), south-eastern Alaska; obverse view (after Churkin and Carter 1970); note strongly acicular proximal end and absence of antivirgellar spines, $\times 7$.

M, '*Diplograptus*' *modestus diminutus* Churkin and Carter, USNM 161701a, Descon Formation, Llandovery Series (*P. acuminatus* and *C. vesiculosus* zones), south-eastern Alaska; obverse view (after Churkin and Carter 1970), $\times 7$.

N, *Glyptograptus gnomus* Churkin and Carter, USNM 161644, Descon Formation, Llandovery Series (*M. cyphus* Zone), south-eastern Alaska; reverse view (after Churkin and Carter 1970), $\times 7$.

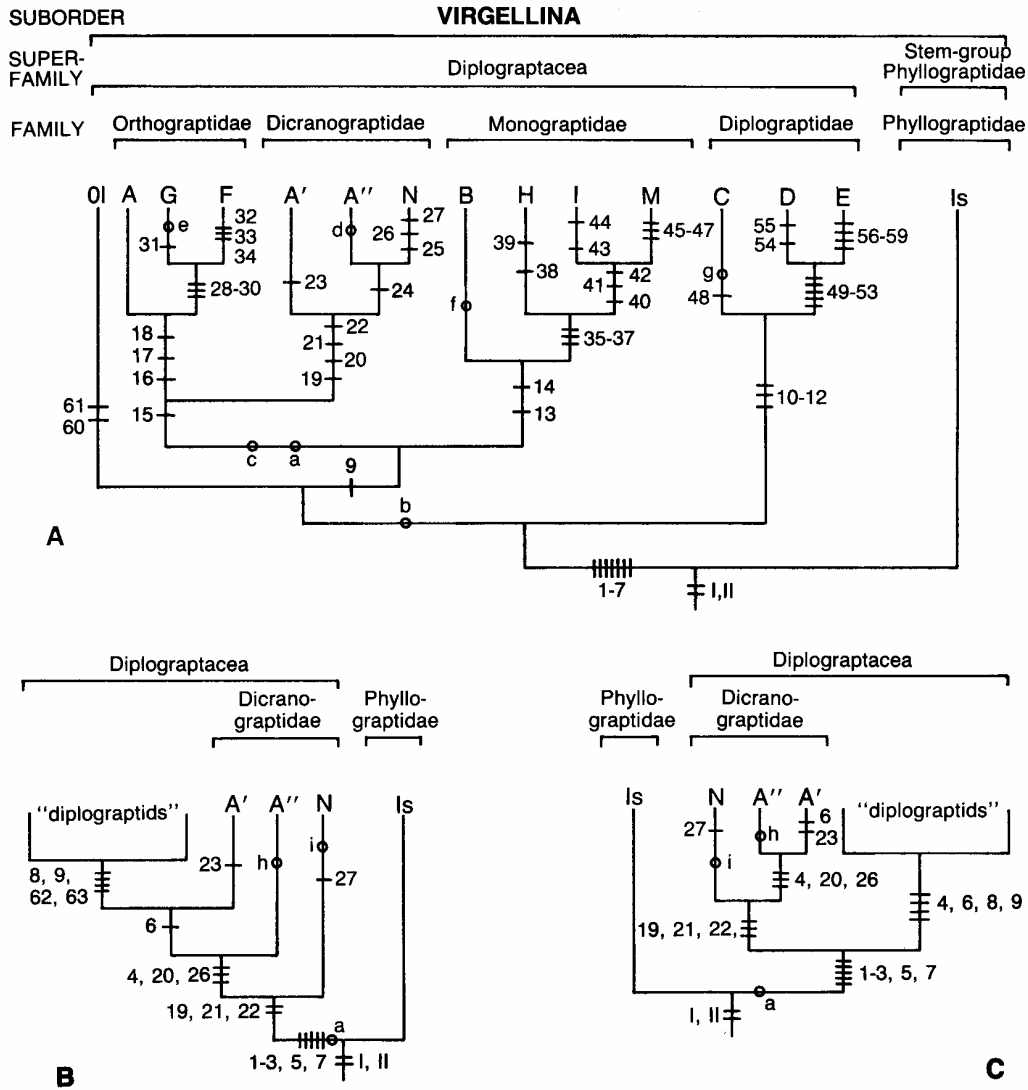

TEXT-FIG. 13. Cladograms illustrating the possible general relationships among the major virgellinid clades, symbolized by the letter designation of their primordial astogenetic pattern (see text-fig. 1; Is, isograptid; M, monograptid; Ol, *Oelandograptus* (gen. nov.) *austrudentatus* and related species) and their classification.

A, preferred relationships with the Dicranograptidae as sister group to the Orthograptidae. Synapomorphies: I, virgella present; II, dichotomy d3 suppressed (see Fortey and Cooper 1986); 1, metasicular origin of th¹; 2, dichotomy d1 delayed to th²; 3, dichotomy d2 suppressed; 4, th¹ with left-handed origin from th¹; 5, metatheca of th² and protheca of th² arise from paired foramina formed by fusion of downward-growing crossing canal of th² with upward-growing flange; 6, scandent dipleural rhabdosome architecture; 7, capacity for cladia generation; 8, sigmoidal thecae; 9, cusped thecal apertures; 10, right-handed origin of th²; 11, sharply geniculate thecae; 12, introverted thecal apertures; 13, asymmetrical proximal end; 14, origin of th² delayed to distal portion of protheca of th² and removed from set of primordial thecae; 15, elaborated sicular aperture; 16, asymmetrical proximal end among advanced species; 17, paired antivirgellar spines among advanced species; 18, delay of dicalycal theca to th³ among advanced species; 19, complex notched and lappet-bearing sicular aperture; 20, colony achieves capacity for wholly or partially uniserial stipes; 21, isolated,

Subfamily NEMAGRAPTINAE Lapworth, 1873, emend. Finney, 1985

Diagnosis. Dicranograptids with horizontal, cladia bearing, uniserial stipes; primordial astogeny nemagraptid (see Finney 1985) with right-handed origin of $th1^2$ from $th1^1$.

Generic group taxa. *Nemagraptus* Emmons. Nemagraptine status of *Amphigraptus* Lapworth, *Pleurograptus* Nicholson, and *Syndyograptus* Ruedemann is probable but remains to be demonstrated.

Family ORTHOGRAPTIDAE fam. nov.

Diagnosis. Diplograptaceans with Pattern A astogeny or the derived Patterns G or F; sicular aperture simple or with antivirgellar spines; thecae sigmoidal primitively but becoming orthograptid or amplexograptid among forms with fully sclerotized periderm, and lasiograptid to retiolitid among others; generally with cusped apertures or with paired apertural spines.

Discussion. Text-fig. 14 presents a detailed cladogram that includes representatives of the broad range of orthograptids. Text-fig. 17 illustrates the approximate geochronological range of the redefined and new orthograptid genera. Among species with Pattern A astogeny, several (e.g. '*Diplograptus*' *uplandicus* Wiman; see text-fig. 2) exhibit a markedly asymmetrical proximal end; $th1^2$ is prosoblastic or nearly so; the crossing canal of $th2^1$ is quite short and the sicula bears a

introverted thecal apertures; 22, geniculate dicranograptid thecae with prominent growth line unconformity in protheca; 23, uni-biserial condition; 24, metathecae of $th1^1$ and $th1^2$ horizontal, forming uniserial, reclined to horizontal stipes; 25, $th1^2$ with right-handed origin from $th1^1$; 26, introversion and apertural isolation of post- $th1^2$ thecae reduced or lost; 27, cladia present; 28, sicula extensively exposed on obverse side; 29, $th1^2$ - $th2^1$ form as a pair and with $th2^2$ non-primordial; 30, second and third crossing canals lost; 31, metatheca of $th1^2$ and protheca of $th2^1$ formed by fusion of upward-growing flange and hood-like crossing canal of $th1^2$; 32, protheca of $th1^2$ is simple upward-growing flange that is not connected to its reduced hood-like crossing canal; 33, metatheca of $th1^2$ and protheca of $th2^1$ formed by division of protheca of $th1^2$; 34, $th1^1$ with metatheca closely pressed against its protheca; 35, crossing canal of $th1^2$ suppressed; 36, protheca of $th1^1$ partly surrounded by its metatheca; 37, $th2^1$ no longer a primordial theca; 38, protheca of $th1^2$ forms from isolated, upward-growing flange; 39, reverse wall of metatheca of $th1^1$ commonly free prior to growth of $th1^2$; 40, reverse lateral wall of metatheca of $th1^1$ in contact with reverse side of sicula; 41, $th1^2$ no longer a primordial theca; 42, capacity to produce proximally uniserial, scandent colonies; 43, sicula extensively exposed along its obverse side; 44, capacity to produce ancora from virgella; 45, uniserial rhabdosome; 46, $th1$ no longer a primordial theca; 47, sicula with porus and lacuna stages in formation of foramen of $th1$; 48, crossing canal of $th2^1$ visible as oval or diamond-shaped patch positioned on or near median plane of rhabdosome; 49, $th2^2$ no longer primordial; 50, dicalycal theca delayed to $th2^2$ or later; 51, asymmetrical sicula strongly deflected to dorsal side; 52, metasicula with bands comprising condensed fuselli; 53, prosicula commonly absent; 54, crossing canal of $th2^1$ reduced to hood-like form; 55, protheca of $th2^1$ formed by upward-growing flange that does not fuse with crossing canal; 56, crossing canal of $th1^2$ suppressed; 57, protheca of $th1^2$ formed from isolated, upward-growing flange; 58, $th2^1$ no longer primordial; 59, virgella reflected across sicular aperture; 60, undulating median septum; 61, sigmoidal thecae with short, nearly vertical supragenicular wall and gentle geniculum. Retained primitive characters: a, quasi-symmetrical proximal end; b, left-handed origin of $th2^1$; c, paired origins of metatheca of $th2^1$ and protheca of $th2^1$ (see 5, above); d, left-handed origin of $th1^2$ from $th1^1$; e, broad proximal end with $th2^1$ occupying region between protheca and metatheca of $th1^1$; f, $th2^1$ with descending crossing canal; g, retained characters 10-12 (see above).

b, alternative cladogram with Dicranograptidae as paraphyletic stem-group occupying intermediate position between 'diplograptids' and Phyllograptidae. Synapomorphies 1-20, 22-25, 27-61 as in a; 21, $th1^1$ and $th1^2$ introverted with isolated, introverted apertures; 26, thecal characteristics of $th1^1$ and $th1^2$ extended throughout rhabdosome; 62, loss of complex features of sicular aperture; 63, loss of prothecal folds and fusellar unconformity in protheca. Retained primitive characters a-g as in a; h, horizontal to reclined stipes (24 of a, above); i, right-handed origin of $th1^2$ (25 of a, above).

c, second alternative cladogram with Dicranograptidae as sister-group to traditional 'diplograptids', but requiring several parallelisms. Synapomorphies and retained primitive characters as in b.

prominent pair of antivirgellar spines. These species are combined in the new genus *Hustedograptus* defined below. The overall configuration of the proximal end of *Hustedograptus* gen. nov. is remarkably similar to that of species of *Orthograptus* (particularly species of the *O. calcaratus* group) and *Amplexograptus* with their Pattern G astogeny (compare text-fig. 2F, K with text-figs. 9G and 10F). While not exactly identical in these advanced Pattern A species and in *Orthograptus* etc., I believe that this complex form produces a gestalt (*sensu* Fortey and Jefferies 1982) which, together with the presence of the paired antivirgellar spines, constitutes a high burden synapomorphy between these groups. This gestalt synapomorphy is maintained largely intact throughout the group of orthograptid species. Such a relationship is also supported by similarities in the form of the thecal apertures among these taxa. The orthograptid cusped thecal aperture, which is prominently displayed in species of *Hustedograptus* gen. nov., is similarly developed in species of *Amplexograptus* and most of the other Peiragraptinae. In the distal thecae of *H. uplandicus*, these cusps develop into prominent lateral apertural spines of the same form and construction as those on the thecae of species in the *O. calcaratus* and *O. quadrimucronatus* groups. I see no justification for segregating those species such as *O. gracilis*, which lack apertural spines, into *Rectograptus* Přibyl. This taxon is defined on the basis of the loss of a single, relatively simple character, and there is no reason to assume that such a loss should be unique.

Pattern G species are linked, in turn, to those with Pattern F (*'Climacograptus' typicalis* Hall and relatives; see Table 1 and text-fig. 8) by the shared presence of paired antivirgellar spines, extensive exposure of the sicula for most of its length in obverse view, the possession of three primordial thecae, and only one crossing canal. These synapomorphies are further strengthened by the great thecal similarities between these 'climacograptids' and peiragraptines such as *A. leptotheca* Bulman. Indeed, the generic placement of such species as '*C. inuiti* Cox has been a persistent problem that reflects their close relationship.

Several of the genera included within this family require significant revision and restriction in their scope. *Orthograptus* does not properly include the Silurian species that have been referred to it. *Orthograptus* Lapworth, with type species *O. quadrimucronatus* (Hall), is a well-known genus comprising a coherent set of similar species, all of which possess a Pattern G astogeny. The Silurian species that have been referred to *Orthograptus* (e.g. '*O. obuti* Rickards and Koren') exhibit a Pattern I astogeny and consequently have a narrow, acicular proximal end. These forms may be subsumed within *Petalograptus* Suess, among the Monograptidae.

Amplexograptus has been a source of persistent confusion. The type species *A. perexcavatus* Lapworth has no holotype and Bulman (1962) selected a neotype (Birmingham University specimen BU 1297) from among the specimens referred to this species and figured by Elles and Wood (1907). As Bulman noted, two distinct species have been confused under this name. Bulman chose a neotype that matches well with the age and morphology of Lapworth's original taxon (Lapworth 1876, 1877). However, it is clearly the other species, *A. fallax* Bulman, that Lapworth (1880) had before him when he made the distinction between typical *Diplograptus* species and members of the species group that Elles and Wood (following Lapworth's lead) later named *Amplexograptus*. Thus, although it has been referred to as *A. perexcavatus* Lapworth, the type species of *Amplexograptus* is in fact the biological entity *A. fallax* Bulman. The species group associated with *A. fallax* is by far the better known. Consequently, the interests of taxonomic stability will be best served by retaining the name *Amplexograptus* for these species, rather than for the '*A. perexcavatus* group. According to ICZN guidelines, I am preparing an application requesting that the Commission exercise its plenary powers to suppress *A. perexcavatus* and establish *A. fallax* as the neotype of the genus. The biological entity originally described by Lapworth (1877) as *D. perexcavatus* is probably not an orthograptid. Rather, both it and *D. pristis* (Hisinger) (the type species of *Diplograptus* M'Coy) appear to have a Pattern C astogeny similar to that of '*C. distichus* (see the discussion for the Family Diplograptidae).

The genera *Glyptograptus* and *Climacograptus*, as presently used, are extremely heterogeneous and include species from each of the three superfamilies. Among the orthograptids, at least two separate species groups with glyptograptid thecae exist: 1, the ancestral diplograptaceans of the

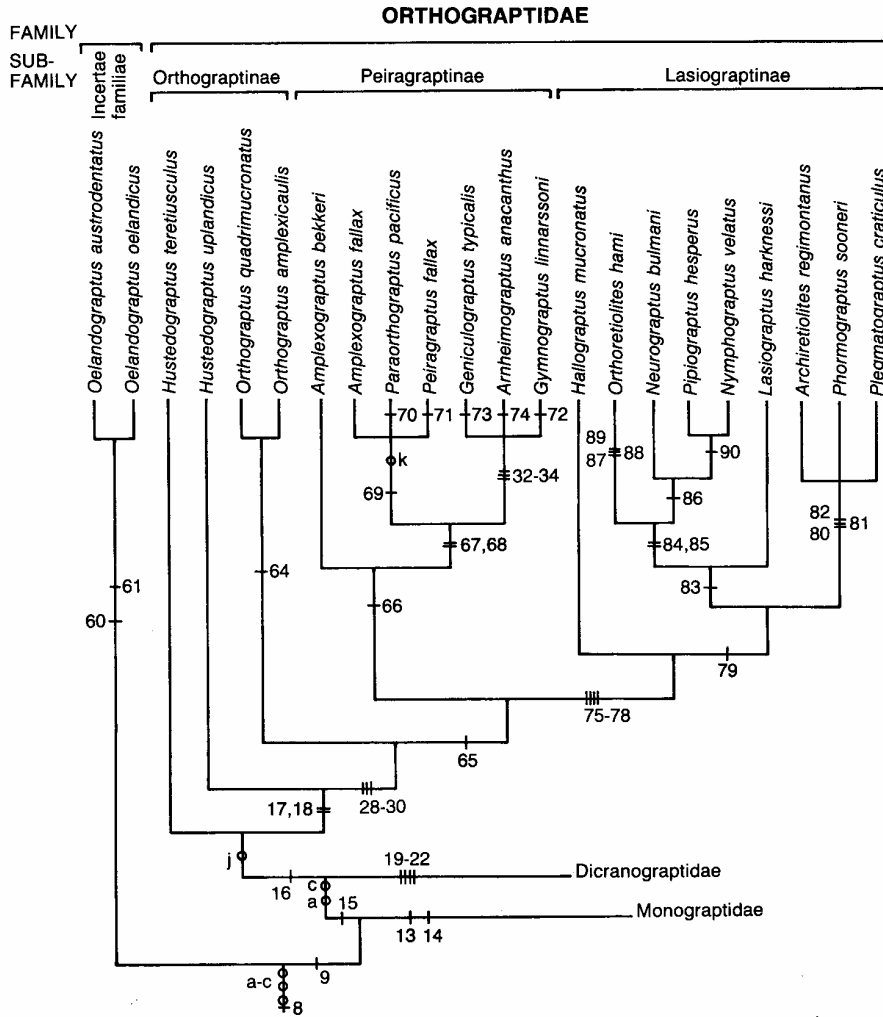

TEXT-FIG. 14. Cladogram and classification of the Orthograptidae, including its relationship to the stem group *Oelandograptus* gen. nov. and the other diplograptacean families. Synapomorphies 1-61 as in text-fig. 13A; 64, orthograptid thecae; 65, sharply geniculate thecae with long straight infragenicular wall, short supragenicular wall, and prominent genicular spines; 66, amplexograptid thecae with genicular flanges present in distal thecae; 67, amplexograptid thecae throughout; 68, aseptate; 69, th¹ sharply upturned at dorsal side of sicula; 70, genicular spines; 71, uni-biserial; 72, gymnograptid thecae with lists; 73, elongate climacograptid thecae in proximal end; 74, glyptograptid thecae; 75, lasiograptid thecae; 76, thecae with reduced fusellar periderm and clathria; 77, lateral (septal) spines or scopulae; 78, bifid genicular spines on post-th¹ thecae; 79, lacinia developed from genicular spines; 80, fusellar periderm of all thecae reduced to clathria except for sicula and initial bud; 81, archiretiolite-like clathrial astogeny; 82, loss of septal spines and scopulae; 83, reduction of flange in ontogeny of crossing canal of th¹; 84, fusellum of all post-th¹ thecae reduced to clathria; 85, loss of reverse wall of th¹ in region of foramen of th¹; 86, pigiograptid thecae; 87, loss of lacinia; 88, simplification of clathria to produce 'orthograptid' thecae; 89, nema in obverse wall; 90, loss of septal spines. Retained primitive characters: j, sigmoidal glyptograptid thecae; k, amplexograptid thecae.

'*G.*' *austrodentatus* group and descendants in the '*G.*' *teretiusculus* species group (here recognized as *Oelandograptus* gen. nov. and *Hustedograptus* gen. nov., respectively); and 2, the minor '*G.*' *anacanthus*-'*G.*' *hudsoni* species cluster (grouped here as *Arnheimograptus* gen. nov.). *Climacograptus*-like species exist in the form of '*C.*' *typicalis*, '*C.*' *inuiti*, and similar species. These species have a thecal form and astogeny different from that of the type species of Hall's genus, *C. bicornis*. *C. bicornis* is fully septate with a dicalycal th_2^2 and a Pattern D astogeny. Its thecae have vertical supragenicular walls, semicircular apertures without apertural cusps, and no genicular flanges. These features indicate a relationship between *Climacograptus s.s.* and the advanced pseudoclimacograptids among the diplograptidae (see below). I propose to combine the species of the '*C.*' *typicalis* group in a new taxon, *Geniculograptus* gen. nov. From text-fig. 14 we can extract the following classification:

Subfamily ORTHOGRAPTINAE subfam. nov.

Diagnosis. Aseptate to septate species with straight median septum; Pattern A or Pattern G astogeny; strongly asymmetrical proximal end with sicula extensively exposed on obverse side; sicula commonly bearing paired antivirgellar spines.

Generic group taxa. *Hustedograptus* gen. nov.; *Orthograptus* Lapworth (= *Rectograptus* Přibyl, non *Ditlograptus* Obut and Sobolevskaya).

Genus HUSTEDOGRAPTUS gen. nov.

Type species. *Diplograptus uplandicus* Wiman, 1895, from erratic boulders of *Chasmops* (= Dalby) Limestone, Upland, Sweden; Viruan Series (*N. gracilis* Zone ?). The reported occurrence of this species in boulders of *Centaurus* Limestone (= Folkeslunda Limestone, in part) (Wiman 1895) has not been confirmed by subsequent studies of this unit.

Diagnosis. Thecae smoothly sigmoidal glyptograptid in the proximal end, becoming orthograptid distally; thecal apertures normal to rhabdosome axis or slightly introverted, with prominent paired cusps or spines on lateral margin and with concave ventral apertural margin; median septum straight with dicalycal theca th_2^1 or substantially delayed; primordial astogeny follows Pattern A but with short descending portion in crossing canal of th_2^1 ; proximal end broad and weakly to markedly asymmetric; sicula with simple aperture, or aperture bearing paired lappets, or antivirgellar spines flanking concave dorsal margin.

Species included. *D. notabilis* Hadding, *D. propinquus* Hadding, *G. teretiusculus* (sensu Jaanusson 1960), *D. uplandicus* Wiman, and *G. vikarbyensis* Jaanusson.

Discussion. Based on a restudy of the type specimens, the proximal end structure of '*D.*' *uplandicus* given by Wiman (1895) appears to be inaccurate. The structure is correctly illustrated in text-fig. 2, based on abundant and excellently preserved material isolated from a limestone sample in the Holm collections of the Naturhistoriska Riksmuseet, Stockholm. This sample is labelled '*Diplograptus*, Kuckers C₂b' and is lithologically identical to the distinctive Kukruse Limestone of Estonia. It is my intention that the type species of the genus *Hustedograptus* gen. nov. be the biological entity embodied by the Estonian material, an entity that I believe to be synonymous with Wiman's *D. uplandicus*.

Hustedograptus gen. nov. differs from *Orthograptus* Lapworth in its primordial astogeny (Pattern A as opposed to Pattern G), the exposure of the sicula only to the level of the aperture of th_1^2 on the obverse side of the rhabdosome, and by the presence of glyptograptid proximal thecae. Additionally, in *Orthograptus* the dicalycal theca is never as early as the second thecal pair (in the type species, *O. quadrimucronatus* Hall, th_5^2 or a later theca is dicalycal) and the sicula always bears paired antivirgellar spines, while in many species of *Hustedograptus* gen. nov. antivirgellar spines are absent. For comparisons with *Oelandograptus* gen. nov. and *Eoglyptograptus* gen. nov. see discussion of these taxa below.

Subfamily PEIRAGRAPTINAE Jaanusson, 1960, emend.

Diagnosis. Orthograptids with Pattern G or Pattern F primordial astogeny; strongly geniculate thecae bearing genicular spines or flanges or both; rhabdosome generally aseptate and with fully sclerotized periderm.

Generic group taxa. Group 1: *Amplexograptus* Elles and Wood, emend., *Paraorthograptus* Mu et al., 1974, and *Peiragraptus* Strachan, 1954. Group 2: *Geniculograptus* gen. nov., *Arnheimograptus* gen. nov., and *Gymnograptus* Bulman.

Discussion. The Peiragraptinae comprises two informal generic groups. Within Group 1 (peiragraptids), *Paraorthograptus* and *Peiragraptus* are little modified from *Amplexograptus* and both retain the basic amplexograptid theca. Within Group 2 (geniculograptids), all three genera share the unique Pattern F astogeny and narrow, gradually widening proximal end, but exhibit variously modified thecal forms.

Genus AMPLEXOGRAPTUS Elles and Wood, 1907

Proposed Neotype species. *Amplexograptus fallax* Bulman, 1962 (subject to approval by the ICZN), Hartfell Shales, Scotland; Caradoc Series (principally *C. wilsoni* Zone).

Emended diagnosis. Thecae amplexograptid with short, slightly outwardly inclined supragenicular walls, sharp geniculum bearing a genicular flange, and with cusped thecal apertures horizontal to slightly everted. Rhabdosomes may be partly septate, with $th3^1$ or some later theca dicalyca, but are more commonly aseptate. Primordial astogeny follows Pattern G. Paired antivirgellar spines generally present on dorsal margin of sicula aperture. $Th1^1$ invariably bears a subapertural or mesial spine but $th1^2$ commonly does not.

Species included. *A. fallax* Bulman, *D. leptotheca* Bulman, *A. maxwelli* Decker, *Climacograptus manitoulinensis* Parks, *A. prominens* Barrass, and *C. bekkeri* Öpik.

Discussion. This name is here applied only to forms with amplexograptid thecae and a Pattern G astogeny (see discussion of the Family Orthograptidae above). *Amplexograptus* is most similar to *Geniculograptus* gen. nov. but differs in the form of its proximal end. *Geniculograptus* species such as *G. inuiti* (Cox), possess a narrow proximal end based on a Pattern F astogeny in which the first theca is tightly upturned and closely pressed against its protheca. Its metatheca extends distally to the level of the bud of $th1^1$ or beyond. In contrast, in Pattern G proximal ends $th1^1$ is always separated from its protheca by a gap through which $th2^1$ develops, and its aperture seldom reaches the level of its primary bud (cf. text-figs. 8F, L, O, 9D, E, H, 10E, F, H). Homeomorphic members of the Diplograptidae (e.g. '*A.*' *munimentus* Berry or '*A.*' *confertus* Lapworth) differ in their possession of simple, semicircular to introverted thecal apertures that lack the lateral lappets of amplexograptid thecae, and a Pattern C astogeny with dicalyca $th2^1$, as well as by the rapid enclosure on the obverse side of the colony of the sicula, which lacks antivirgellar spines.

Genus GENICULOGRAPTUS gen. nov.

Type species. *Climacograptus typicalis* Hall, 1865, Lexington Limestone and Kope Formation, Cincinnati Region, USA; Blackriveran to Maysvillian Stages (*C. americanus* to *A. manitoulinensis* zones).

Diagnosis. Aseptate, gradually widening rhabdosomes with narrow proximal end; slightly outwardly inclined amplexograptid thecae bearing a variably prominent genicular flange; primordial astogeny follows Pattern F; sicula is extensively exposed on the obverse side of the rhabdosome and bears paired antivirgellar spines in addition to the virgella. $Th1^1$ may or may not bear a mesial spine. $Th1^2$ bears no spines.

Species included. *C. inuiti* Cox, *C. latus* Elles and Wood, *C. typicalis magnificus* Twenhofel, and *C. pygmaeus* Ruedemann.

Discussion. Species of *Geniculograptus* gen. nov. most resemble those of *Amplexograptus* in the form of their thecae, but they differ astogenetically (see discussion above for *Amplexograptus*). They also resemble certain members of the Monograptidae, such as *Paraclimacograptus innotatus* and *P. nevadensis*, which also possess amplexograptid-like thecae with prominent genicular flanges, but again these taxa differ in the form of their proximal end and rhabdosome architecture. Among *Geniculograptus* species, the sicula bears prominent antivirgellar spines and is extensively exposed on the obverse side of the rhabdosome, which is aseptate. Those of *Paraclimacograptus*, with their Pattern H astogeny, are generally septate, the sicula is rapidly enclosed by the early thecae, and there are no antivirgellar spines (see Table 2).

Genus ARNHEIMOGRAPTUS gen. nov.

Type species. *Glyptograptus lorrainensis anacanthus* Mitchell and Bergström, 1977, Arnheim Formation, Cincinnati Region, USA; Richmondian Stage (*A. manitoulinensis* Zone).

Diagnosis. Minute aseptate species with glyptograptid thecae; thecal apertures undulating to cusped; th1¹ may or may not possess a mesial spine; primordial astogeny follows Pattern F.

Species included. *G. anacanthus* Mitchell and Bergström, *G. hudsoni* Jackson, and *G. lorrainensis* Parks.

Discussion. The rhabdosomes of these species exhibit a proximal end which is nearly identical to that of *Geniculograptus* gen. nov. species. The common ancestor of the *Arnheimograptus* species probably arose from one of these by the loss of the distinctive genicular flanges, converting the amplexograptid thecae of *Geniculograptus* gen. nov. to the glyptograptid thecae of *Arnheimograptus*. Also like *Geniculograptus* gen. nov., this taxon differs from similar looking species of *Glyptograptus* in being aseptate, by exhibiting a long slender sicula that is extensively exposed on the obverse side of the colony, and in possessing antivirgellar spines on the dorsal margin of the sicula.

Genus GYMNOGRAPTUS Bulman, 1953, emend.

Type species. *Gymnograptus linnarssoni* (Moberg, 1896), *Ogyiocaris* Shale, Crassicauda (= Furudal) Limestone, Baltoscandia; Uhakuan Stage (*H. teretiusculus* Zone).

Discussion. Taxon remains as described by Bulman except that it is here restricted to species which, like the type species, possess a Pattern F primordial astogeny. Thus, species such as '*G. retioloides*' (Wiman), with its Pattern C astogeny, belong among the Diplograptidae (see below). *G. linnarssoni* differs from typical Pattern F proximal form in that the sicula possesses only a single dorsal antivirgellar spine.

Subfamily LASIOGRAPTINAE Lapworth, 1879, emend.

Diagnosis. Species with Pattern G primordial astogeny; thecal periderm reduced to absent; thecae with prominent lists and commonly bearing lacinia derived from genicular and lateral spines; thecae lasiograptid to highly stylized, polygonal clathrium.

Generic group taxa. Group 1: *Lasiograptus* Lapworth, *Hallograptus* Lapworth, *Orthoretiolites* Whittington, *Neurograptus* Elles and Wood, *Pipiograptus* Whittington, and ?*Nymphograptus* Elles and Wood. Group 2: *Plegmatograptus* Elles and Wood, *Arachniograptus* Ross and Berry, *Phormograptus* Whittington, and *Archiretiolites* Eisenack.

Discussion. This subfamily includes two generic groups that are clearly related but none the less distinct in their colonial architecture. Group 1 (lasiograptids) consists of forms exhibiting lasiograptid to *Pipiograptus*-like thecae with prominent genicular spines; sicula and at least th1¹ partly sclerotized; typical Pattern G astogeny; clathria, lateral (septal) spines, and at least partial lacinia common. *Hallograptus* has the appearance of a primitive stem group with respect to the core of this assemblage because of its lack of a lacinia and somewhat better sclerotized thecae (which resemble the proximal thecae of *A. bekkeri* and possess weaker clathria than the main group of

lasiograptids). [I consider the absence of a lacinia and the generally simple architecture of *Orthoretiolites* to be a derived condition based on considerations discussed more fully elsewhere.] This group includes several retiolitid-like taxa formerly classed in the polyphyletic Archiretiolitinae Bulman, 1955. *Nymphograptus* is included here with some reservation because its structure is very incompletely known.

Group 2 (archiretiolitids) comprises retiolitid rhabdosomes with a sclerotized sicula bearing antivirgellar spines; thecal fusellum represented only by clathria; clathrium generally irregularly organized and complexly connected with well developed lacinia; primordial astogeny like that of *Archiretiolites*. Although the phylogeny of these highly derived and structurally reduced archiretiolitid colonies is somewhat difficult to evaluate, their orthograptid sicula with antivirgellar spines and a lacinia derived from paired genicular or subapertural spines allies the archiretiolitids with the lasiograptids among the Orthograptidae, and clearly separates them from any close phylogenetic relationship with the Silurian Retiolitinae.

The Lasiograptinae include an unusually large number of monotypic genera and it is quite likely that, as these taxa become better known, several may prove to be synonymous (e.g. *Pipio-graptus* with *Neurograptus*). As discussed by Finney (1980) the abrograptid *Reteograptus* of the Phyllograptidae Lapworth (emend. Cooper and Fortey, 1982) is distinguished from the archiretiolitids by its possession of an isograptid primordial astogeny and a small, simple sicula that lacks antivirgellar spines.

Incertae familiae

Genus OELANDOGRAPTUS gen. nov.

[= *Undulograptus partim* Jenkins, 1980; non *Undulograptus* Bouček, 1973]

Type species. *Glyptograptus austrodentatus oelandicus* Bulman, 1963a, Hølen Limestone (= Glaukonithaltig grå Vaginatumkalk of Holm and Bulman), Öland; Ontikan Series, Kunda Stage (*D. hirundo* and *D. bifidus* zones).

Diagnosis. Median septum undulatory, weakly sigmoidal thecae with long, outwardly inclined infragenicular wall, sharply rounded geniculum and short, nearly vertical supragenicular wall. Thecal apertures slightly everted and undulatory with a concave ventral margin. Sicular aperture simple. Primordial astogeny follows Pattern A and the proximal end is evenly rounded to somewhat blunt and nearly symmetrical.

Species included. *G. a. americanus* Bulman, *G. austrodentatus* Harris and Keble, *G. a. oelandicus* Bulman, and *G. sinodentatus* Mu and Lee; *G. curvithecatus* Mu and Lee is imperfectly known but may also belong here.

Discussion. *Oelandograptus* gen. nov. differs from its contemporaries *Hustedograptus* gen. nov., *Undulograptus* Bouček, and *Pseudoclimacograptus* (*Archiclimacograptus*) subgen. nov. in several respects. Species of *Oelandograptus* gen. nov. are most similar to the archaic *Pseudoclimacograptus* species of *P.* (*Archiclimacograptus*) subgen. nov. but differ in possessing a Pattern A astogeny, an undulatory median septum, and weakly geniculate thecae with apertures normal to the rhabdosome axis; the latter exhibit a Pattern C astogeny (see Table 2), generally have a sharply zigzag median septum, and pseudoclimacograptid thecae with introverted apertures. *Undulograptus* Bouček, as redefined here, is a monotypic taxon with a narrow proximal end based on primordial astogenetic Pattern B and a climacograptid thecal form exhibiting a nearly vertical supragenicular wall. *Hustedograptus* gen. nov. has more strongly glyptograptid proximal thecae, thecae with prominently cusped apertures, and a more asymmetrical proximal end (still based on Pattern A), together with a straight median septum.

Orthograptid history. The Orthograptidae were an important constituent of graptoloid faunas from the early Llanvirn to the late Ashgill. Their initial diversity was eclipsed by that of the Diplograptidae but advanced orthograptids dominated the faunas of the Upper Ordovician. This situation changed

radically at the end of the Ordovician when the orthograptids appear to have become extinct. All of the early Silurian diplograptaceans, based on their possession of astogenetic Patterns H and I, were monograptids. [I am indebted to Anton Kearsley who pointed out to me, in 1981, the magnitude of these late Ordovician and early Silurian extinctions and their effects on the taxonomic composition of the Silurian diplograptacean radiation.] Thus, the Silurian species currently referred to the genera '*Amplexograptus*' and '*Orthograptus*' are not particularly closely related to the species of these Ordovician taxa.

One outstanding problem for the systematics of Ordovician diplograptaceans is the fact that our knowledge of the astogeny of many of the Arenig to Llandeilo species previously included in *Diplograptus*, *Glyptograptus*, and *Amplexograptus* is quite limited. Some of these species may possess either a Pattern A or G astogeny, while others will certainly be found to exhibit a Pattern C or perhaps even a Pattern B proximal end structure. Additional study of material from this interval, preserved in relief or in isolated preparations, is needed to resolve the cladistic relationships and systematic associations of the early diplograptaceans. Such study is of particular importance because it is in just this interval that several of the fundamental steps in diplograptacean evolution occurred, including the establishment of all four of the diplograptacean families.

Family DIPLOGRAPTIDAE Lapworth, 1873, emend.

Diagnosis. Rhabdosomes generally septate with pseudoclimacograptid to climacograptid and amplexograptid to orthograptid (rarely gymnograptid or lasiograptid) thecae, and with primordial astogenetic Pattern C or its derivatives D and E. Sicula commonly deflected toward its dorsal side and rapidly enclosed by the second thecal pair. Sicular aperture simple, lacking paired antivirgellar spines. Many species with a three-vaaned nematularium formed from an intact nema.

Discussion. The second major subclade among the Diplograptacea is the pseudoclimacograptines and their descendants, the diplograptines and true climacograptines. Text-fig. 15 presents a cladogram of the branching history of the taxon. The primitive diplograptid astogenetic pattern, Pattern C, differs from the ancestral diplograptacean Pattern A in the right-handed rather than left-handed origin of $th2^1$ from $th1^2$. The crossing canal of $th2^1$, on its way toward the virgella, grows out from the sicula and arcs around the crossing canal of $th1^2$ (text-figs. 2L, O, P and 4). This peculiar origin of $th2^1$ (best known in *P. eurystoma* Jaanusson, *P. angulatus*, '*C.*' *distichus* Eichwald, and '*G.*' *retioloides*) is shared with the advanced diplograptid pattern, Pattern D (e.g. *P. scharenbergi*; cf. text-fig. 6), clearly indicating that these two groups share a close common ancestry. This relationship is also fully corroborated by the correspondence in thecal form and rhabdosome architecture among these graptolites. Indeed, the form of the thecae and shape of the proximal end indicate that the advanced pseudoclimacograptines, such as *P. scharenbergi*, appear to be directly descended from an archaic form with a Pattern C astogeny (e.g. *P. eurystoma*). The species '*L.*' *haplus* Jaanusson, with its compact proximal end and Pattern C astogeny, also appears to be very closely allied to pseudoclimacograptines like *P. eurystoma*.

Primordial astogenetic Pattern D is not confined to species with pseudoclimacograptid rhabdosomes. It is also present in *C. bicornis* (Hall), the type species of *Climacograptus* (text-fig. 6J-P), and several other related species (see text-fig. 15). This high burden synapomorphy unambiguously allies *Climacograptus*, *sensu stricto*, with the advanced pseudoclimacograptines and removes them from the possibility of any close phylogenetic relationship to species of either the *Geniculograptus typicalis* group (see above) or the '*C.*' *brevis*/*C.*' *normalis* group, which possess a Pattern H development and are allied to the Monograptidae (see below). Finally, several species such as '*C.*' *distichus*, '*C.*' *meridionalis* Ruedemann, and '*A.*' *munimentus* Berry possess a Pattern C astogeny. Given the relationships of *C. bicornis* to advanced pseudoclimacograptids with a Pattern D astogeny, these species must have acquired their climacograptid thecae independently of *C. bicornis* and related species (in contrast to Riva's 1976 suggestions). Hence, they too must be classed separately from the true climacograptines. However, it should not be difficult to recognize these as a separate group, given their proximally zigzag median septum and broad, blunt proximal end.

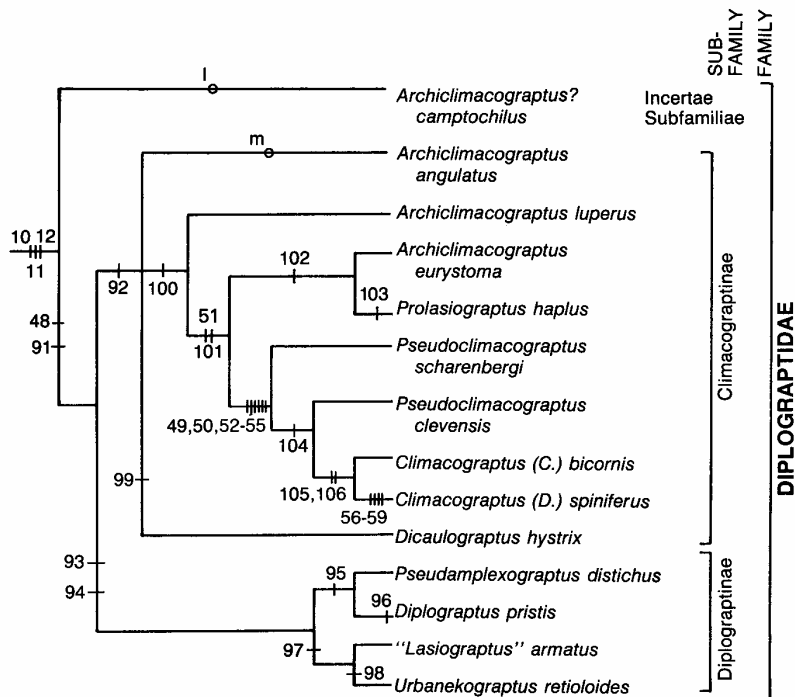

TEXT-FIG. 15. Cladogram and classification of the Diplograptidae. Synapomorphies 1–61 as in text-fig. 13A; 91, $th1^1$ and $th1^2$ with open curvature producing a broad, blunt proximal end; 92, metathecae of $th1^1$ and $th1^2$ with pronounced convex ventral walls and introverted apertures; 93, $th1^1$ and $th1^2$ with subhorizontal metathecae and generally with horizontal to everted apertures throughout; 94, 'amplexograptid' thecae with simple semicircular to introverted apertures and short, nearly vertical supragenicular walls; 95, straight median septum; 96, distal thecae orthograptid to glyptograptid; 97, genicular spines; 98, 'gymnograptid' thecae with well-defined clathria; 99, unique spinose dorsal margin of sicular aperture and with isolated, strongly introverted and spinose thecal apertures bearing fenestrate lateral processes; 100, flange of $th2^1$ formed on dorsal side of $th1^2$; 101, narrow, evenly rounded proximal end with tightly upturned $th1^1$; 102, open, semicircular apertures; 103, 'lasiograptid' thecae lacking genicular spines or lacinia but with clathria; 104, climacograptid thecae with relatively long, straight, and nearly vertical supragenicular wall; 105, straight median septum; 106, narrow, nearly parallel-sided rhabdosome. Retained primitive characters: **l**, archaic geometry of descending crossing canal of $th2^1$ along mid-line of colony in narrow proximal end; **m**, broad proximal end.

Species of the *C. spiniferus* Ruedemann species group, with their Pattern E astogeny, share with *C. bicornis* and *C. cf. caudatus* (Strachan 1974, cf. pl. 6, figs. 1, 7, 9 with figs. 2 and 3, and text-fig. 7 herein) an unusual sicula: the prosicula is absent and replaced by a stirrup-like set of rods; the metascula is strongly deflected to the dorsal side and bears a series of regularly spaced dark bands. These synapomorphies link the *C. spiniferus* and *C. bicornis* species groups. Based on the overall morphology, proximal end structure, and stratigraphic occurrence of these species, Riva (1976) arrived at the conclusion that *C. spiniferus* is descended from *C. bicornis*. A similarly close relationship is shown in text-fig. 15. Despite the highly simplified astogeny of the distinctive Pattern E species, they are best retained within Hall's genus, although they can easily and usefully be recognized as a subgenus: *C. (Diplacanthograptus)* subgen. nov.

The taxa *Metaclimacograptus* and *Clinoclimacograptus*, recognized by Bulman and Rickards (1968) and included as subgenera of *Pseudoclimacograptus*, appear to possess a Pattern H astogeny. Michael Melchin (pers. comm.) has acquired numerous isolated growth stages of several metaclimacograptid and clinoclimacograptid species during his studies of Llandoveryan biserial diplograptaceans from arctic Canada. These specimens confirm that even the most pseudoclimacograptid-like of these species, *M. orientalis* Obut and Sobolevskaya, possess a Pattern H astogeny. They are, thus, homeomorphic with Ordovician pseudoclimacograptines and represent a Silurian 're-invention' of this rhabdosome architecture among the Monograptidae, following the extinction of pseudoclimacograptine diplograptids in the latest Ordovician.

The Diplograptidae appear to have undergone a significant dichotomy early in their history. In the second branch of the family, th1¹ and th1² acquired a more horizontal growth form with only the apertural regions sharply upturned. This configuration gave these diplograptids a broad and rather blunt proximal end that commonly attains widths nearly as great as the maximum colony width. This group, the subfamily Diplograptinae, includes species with a much broader range of thecal types than exist among the Climacograptinae. Within the subfamily occur several species-groups in which rhabdosomes exhibit thecae homeomorphic with those of such orthograptid taxa as *Amplexograptus*, *Orthograptus*, *Hallograptus*, and *Gymnograptus*. The most important of these taxa are *Diplograptus* M'Coy and *Pseudamplexograptus* gen. nov. The latter comprises the archaic amplexograptus-like species, such as '*A.* confertus' (Lapworth), '*A.* munimentus' Berry, and '*C.* distichus' (Eichwald), and it includes most of the species from the Arenig to the Llandeilo that have formerly been assigned to *Amplexograptus*—where they have resided uncomfortably (see Bulman 1962).

The status of *Diplograptus* remains particularly problematic. *D. pristis* (Hisinger) is known only from flattened material, but Skoglund's (1963) preparations of isolated, flattened specimens from the type area in Sweden provide useful information. Its broad, blunt proximal end that rapidly encloses a short, stout sicula lacking antivirgellar spines suggests a Pattern C astogeny. Thecal characters of the proximal end are also like those of *Pseudamplexograptus* gen. nov. This suite of characters exhibited by *D. pristis* appears to be shared with many other species assigned to this genus. Additionally, I have isolated specimens of a species similar to *D. decoratus* Harris and Thomas from the Table Head Formation, Western Newfoundland, and its growth stages exhibit a Pattern C astogeny. Finally, it is noteworthy that, like many pseudoclimacograptines, species of *Diplograptus* (sensu stricto) often possess a retuse, three-vaaned nematularium derived from the distal extremity of their intact nema (see Ruedemann 1904; Mitchell and Carle 1986). To my knowledge, nematularia of the *conulare*-type (Müller and Schauer 1969) do not occur in other diplograptacean families during the Ordovician.

Not all of the Arenig to Caradoc species that have been classed with *Diplograptus* exhibit these features, however. '*D.* propinquus' Hadding and '*D.* notabilis' Hadding belong among the Pattern A-bearing *Hustedograptus* gen. nov., in which weak thecal gradients encompass glyptograptid to orthograptid shapes. Still others (e.g. '*D.* toernquisti' Hadding) possess a Pattern H astogeny that places them among the Monograptidae. Considerable additional work needs to be done on this group.

Subfamily CLIMACOGRAPTINAE Frech, 1897, emend.

Diagnosis. Diplograptids with zigzag to straight median septum and pseudoclimacograptid to climacograptid thecae; th1¹ and th1² grow distally in a gentle arc producing a rounded proximal end. Primordial astogeny is Pattern C or D.

Generic group taxa. *Pseudoclimacograptus* Přibyl, s.s. (non *Metaclimacograptus* Bulman and Rickards; non *Clinoclimacograptus* Bulman and Rickards), comprising the subgenera *P.* (*Pseudoclimacograptus*) Přibyl and *P.* (*Archiclimacograptus*) subgen. nov.; *Prolasiograptus* Lee; *Climacograptus* Hall, 1865, emend., comprising the subgenera *C.* (*Climacograptus*) Hall and *C.* (*Diplacanthograptus*) subgen. nov.; *Dicaulograptus* Rickards and Bulman.

Subgenus PSEUDOCLIMACOGRAPTUS (PSEUDOCLIMACOGRAPTUS) Přibyl, 1947, emend.

Type species. *Climacograptus scharenbergi* Lapworth, 1876, Balclatchie beds and Lower Hartfell Shale, Scotland; Caradoc Series ('D.' *multidens* and 'C.' *wilsoni* zones).

Diagnosis. Climacograptines with narrow, rounded proximal end and Pattern D astogeny, including a dicalycal th². Region between the metatheca of th¹ and th² on the reverse side occupied by the protheca of th².

Species included. Those few species known to possess this suite of characters include *P. scharenbergi* (Lapworth) and *P. clevensis* Skoglund.

Subgenus PSEUDOCLIMACOGRAPTUS (ARCHICLIMACOGRAPTUS) subgen. nov.

Type species. *Pseudoclimacograptus angulatus sebyensis* Jaanusson, 1960, Grey Seby Limestone, Seby and Folkeslunda Limestone, Sjöstorp, Öland; Viruan Series, Lasnamägi Stage (*D. murchisoni* Zone).

Diagnosis. Taxon with broadly rounded proximal end and Pattern C astogeny; median septum sharply zigzag to undulatory. Th² generally dicalycal and with the region between the metatheca of th¹ and th² on the reverse side occupied by an exposed patch of the right-handed crossing canal of th² flanked or enclosed by the prothecae of both th¹ and th².

Discussion. *P. (Archiclimacograptus)* subgen. nov. differs from the nominate subgenus by its possession of a relatively broad and blunt proximal end, based on a Pattern C astogeny, and a dicalycal th², in contrast to the rather more narrow and evenly rounded proximal end of *P. (Pseudoclimacograptus)*, with its Pattern D astogeny and dicalycal th² (see Table 2). It differs from *Pseudamplexograptus* gen. nov. in the form of the thecae and median septum (see below). Species of *Metaclimacograptus* and *Clinoclimacograptus* exhibit a Pattern H astogeny that produces a slender, nearly parallel-sided rhabdosome and allies them unambiguously with the Monograptidae. They also possess a complexly folded, rather than strictly zigzag, median septum.

Although the species *P. ? camptochilus* Skevington and *P. ? formosus* Mu and Lee are known from isolated and well-preserved relief material, respectively, and possess the thecal characters of the genus, they are doubtfully included in *P. (Archiclimacograptus)* subgen. nov. The symmetrical form of their proximal end, in which the descending crossing canal of th² lies along the mid-line of the colony and is extensively exposed, suggests a Pattern A rather than Pattern C astogeny. This remains to be confirmed from the study of early growth stages, however. In any event, their primitive geometry places this species group as a paraphyletic stem group in text-fig. 15.

Species included. Structurally well-known members of this taxon include *P. angulatus angulatus* (Bulman), *P. a. sebyensis* Jaanusson, *P. luperus* Jaanusson, *P. marathonensis* Clarkson, *P. modestus* (Ruedemann), and *P. oliveri* Bouček. The form of the proximal end of *P. eurystoma* Jaanusson closely resembles that of typical members of *P. (Pseudoclimacograptus)*, differing only in its retention of a Pattern C astogeny with an exposed patch of the crossing canal of th² between the apertures of th¹ and th² on the reverse side of the rhabdosome.

Genus PROLASIOGRAPTUS Lee, 1963, emend.

Type species. *Lasiograptus retusus* Lapworth, 1880, 'upper Llandeilo shales of the neighbourhood of Llandrindod Wells, Radnorshire', Wales; Llandeilo Series (*N. gracilis* Zone ?).

Diagnosis. Taxon restricted to Climacograptinae with Pattern C astogeny, lasiograptid thecae, and without lacinia.

Discussion. Distinguished from similar looking species of *Lasiograptus* by its proximal end structure, absence of antivirgellar spines, and simple thecal apertures.

Species included. Known to include *L. haplus* Jaanusson, 1960, in addition to the type species.

Genus CLIMACOGRAPTUS Hall, 1865, emend.

Type species. *Graptolithus bicornis* Hall, 1848, Austin Glen Greywacke, Norman's Kill, New York (but also common in equivalent units world wide); Mohawkian Series, Blackriveran to Shermanian stages (*N. gracilis* and 'D.' *multidens* zones).

Emended diagnosis. Climacograptines with climacograptid thecae, bearing semicircular thecal excavations that lack apertural cusps, nearly vertical supragenicular walls, and a sharp geniculum without genicular flanges. Proximal end narrow, evenly rounded to blunt, based on a Pattern D or Pattern E astogeny. Sicula strongly deflected toward its dorsal side, generally lacking a normal prosicula, and with an aperture bearing only a prominent virgella. Rhabdosome septate with proximally zigzag to straight median septum. Th2² generally dicalycal.

Discussion. Species of *Climacograptus* Hall differing from similar looking taxa in *Geniculograptus* gen. nov., *Glyptograptus*, *Pseudamplexograptus* gen. nov., and *Undulograptus* in the form of the thecae, or the proximal end (including the configuration of the sicula), or both. Genus consists of two subgenera.

Subgenus CLIMACOGRAPTUS (CLIMACOGRAPTUS) Hall, 1865, emend.

Type species. *Graptolithus bicornis* Hall, 1848, see above.

Diagnosis. Characters of genus, but restricted to species with Pattern D astogeny.

Species included. Species well enough known to be assigned with confidence include *C. caudatus* Lapworth, *C. hastatus* T. S. Hall, *C. raricaudatus* Ross and Berry, *C. tubuliferous* Lapworth, *Diplograptus minimus* Carruthers, and *G. putillus* Hall.

Discussion. Among species of the nominate subgenus the crossing canal of th1² exhibits an evenly rounded curvature and constant diameter as it sweeps across the reverse side of the sicula at the level of the sicular aperture. The globular protheca of th2¹ occupies the region encircled by th1² and commonly bears a distinct dimple that corresponds to the end of a list which links the enclosing protheca with the hood-like crossing canal below (see text-figs. 5 and 6). The sicula commonly bears a long stiff virgella that projects downward. The first thecal pair may be without spines, or th1¹ alone, or both it and th1² may possess prominent mesial spines.

C. (Climacograptus) is most similar to *Pseudamplexograptus* gen. nov. but differs in that the latter, despite their climacograptid thecae, retain a Pattern C astogeny, which produces a broad, blunt proximal end and a rather wide, tabular rhabdosome (see also Table 2). The sicular form of *Climacograptus* is highly distinctive but difficult to observe. Some species of *C. (Climacograptus)*, such as *C. (C.) caudatus* (see text-fig. 6R), exhibit a proximally zigzag median septum, but in all species the median septum is straight after the first few thecal pairs, thus distinguishing them from species of *Pseudoclimacograptus*.

Subgenus CLIMACOGRAPTUS (DIPLACANTHOGRAPTUS) subgen. nov.

Type species. *Climacograptus spiniferus* Ruedemann, 1908, lower Utica Shale, Hudson and Mohawk River valleys; Mohawkian and Cincinnati Series, Blackriveran to Edenian Stages (*C. americanus* to *C. pygmaeus* zones).

Diagnosis. Species of *Climacograptus* with Pattern E primordial astogeny and a narrow, asymmetrical proximal end with the sicula lying almost entirely to the right of rhabdosome mid-line in obverse view; sicular aperture oriented at about 70° from the rhabdosome axis and bearing a stout (but not necessarily long) virgella deflected across the sicular aperture. Virgella commonly matched by a long mesial spine on th1¹ such that they form a pair which, in an undeformed state, is symmetrical about the rhabdosome axis. More rarely th1² bears a small mesial spine as well.

Species included. *C. dorotheus* Riva and *C. spiniferus* Ruedemann. At present, the astogenetic details of *C. venustus* Hsu, *C. longispinus* T. S. Hall, and related species are unknown, but their possession of a reflected

virgella that is symmetrical with a mesial spine on $th1^1$, plus a strongly asymmetrical proximal end, both suggest that they belong here rather than in *C. (Climacograptus)*.

Discussion. Differs from *C. (Climacograptus)* in its possession of a Pattern E astogeny and in the unique configuration of its sicula.

Subfamily DIPLOGRAPTINAE Lapworth, 1873, emend.

Diagnosis. Diplograptids with a broad and blunt proximal end that arises from a strong lateral component in the growth of the first thecal pair and a Pattern C primordial astogeny; thecae amplexograptid to orthograptid, or rarely gymnograptid.

Generic group taxa. *Diplograptus* M'Coy, *Pseudamplexograptus* gen. nov., and *Urbanekograptus* gen. nov. The status of *Diplograptus* remains uncertain due to our poor understanding of the type species, *D. pristis* (Hisinger) (see discussion of Diplograptidae). The species of the 'L.' *armatus-porrectus* Bulman group may also belong in this family. These species appear to combine amplexograptid thecae bearing prominent genicular spines with a diplograptid-like proximal end, but the details of their development are unknown. Similarly, many of the other species referred to '*Lasiograptus*' and '*Hallograptus*' among the Llanvirn and Llandeilo faunas will probably prove to belong here.

Genus PSEUDAMPLEXOGRAPTUS gen. nov.

Type species. *Lomatoceras distichus* Eichwald, 1840, Lasnamägi strata, Estonia, but best known from the Seby and Folkeslunda Limestones, Öland, Sweden; Lasnamägi Stage (upper *D. murchisoni* Zone).

Diagnosis. Species having broad, tabular, and nearly parallel-sided rhabdosomes with amplexograptid thecae throughout. Thecal excavations deep and semicircular to somewhat restricted, commonly with strong apertural selvage; apertures horizontal to introverted and lacking lateral cusps. The supragenicular wall is short and commonly of similar height to that of the thecal excavation; geniculum sharp and frequently with genicular flange. Proximal end blunt and nearly as wide as distal colony width. Primordial astogeny follows Pattern C; $th2^1$ generally dicalycal with proximally zigzag to straight, complete median septum. Sicula exposed on obverse side only to level of $th1^2$ aperture, or slightly above, and bearing only a stout virgella.

Species included. *C. confertus* Lapworth, *C. distichus* Eichwald, *C. meridionalis* Ruedemann, *A. latus* Bulman, *A. maxwelli* Ekström (non Decker), and *A. munimentus* Berry.

Discussion. *Pseudamplexograptus* differs from *Aplexograptus* in its proximal end structures (Pattern C rather than Pattern G astogeny and morphological correlates: see Table 2), absence of antivirgellar spines, extent of exposure of the sicula, and in the simple thecal excavations. For comparison with *Climacograptus* and *Pseudoclimacograptus* see discussion of these taxa above.

Genus URBANEKOGRAPTUS gen. nov.

Type species. *Climacograptus retioloides* Wiman, 1895, from erratic boulder of Scandinavian origin but probably from the *Crassicauda* (= Furudal) or *Ludibundus* (= Dalby) Limestones, Sweden; Uhaku or Kukruse Stages (*H. teretiusculus* or *N. gracilis* zones).

Diagnosis. Diplograptines with gymnograptid thecae bearing complex spinose genicular processes, Pattern C primordial astogeny, and nearly symmetrical, blunt proximal end. $Th1^1$ and $th1^2$ with orthograptid shape and prominent apertural spines.

Discussion. Taxon distinguished from homeomorphic *Gymnograptus* by its astogeny, the broad shape of the proximal end with its subhorizontal first two thecae and by the absence of antivirgellar spines. Taxon presently monotypic.

Summary history of the Diplograptidae

Compared to the other diplograptacean superfamilies the Diplograptidae form a relatively small and close-knit assemblage. They appear to have achieved their maximum diversity and peak abun-

dance early in the history of the diplograptacean radiation—during the Llanvirn and Llandeilo (text-fig. 17), when members acquired a range of thecal shapes and rhabdosome designs that are strikingly similar to those evolved later among the Orthograptidae. But by the mid-Caradoc, the diplograptids had begun to wane in importance, losing their status as common and numerous components of the diplograptid fauna. Species of *Climacograptus* (particularly in the subgenus *Diplacanthograptus*), however, did remain as highly distinctive elements and continued to evolve rapidly (hence their common use in zonation and chronostratigraphic correlation). Yet, they too were extinguished in the Ordovician–Silurian mass extinction. The Diplograptidae, like the Orthograptidae, apparently made no contribution to the great Silurian diplograptacean renaissance.

Family MONOGRAPTIDAE Lapworth, 1873, emend.

Diagnosis. Rhabdosomes with narrow, asymmetrical proximal end and simple sicula; colonies may be biserial, uni-biserial, or fully uniserial. In biserial taxa the first two thecae are closely pressed to the sicula and lack mesial spines. Primitively, thecae are glyptograptid to climacograptid, but are modified to petalograptid, pseudoclimacograptid, or variously isolate, lobate, hooked, or triangular—particularly among the Monograptinae. Primordial astogeny is Pattern B, modified to Patterns H, I, or the monograptid pattern. Silurian representatives develop virgellar meshworks and ancora-based retiolitid colonies while others develop thecal and sicular cladia to re-establish multi-stiped, spreading colony forms.

Discussion. The fourth major division of the Diplograptacea encompasses '*G.* *dentatus* Brongniart, its congeners, and their descendants. Bulman (1963b) considered the prosoblastic form of th1² in the astogeny of '*G.* *dentatus* to be distinctive of that species and all its descendants. This has proved not to be true, however. Derived members of both the Orthograptidae and Diplograptidae also develop a prosoblastic th1², i.e. species with Patterns E, F, and G. The distinctive elements of a Pattern B astogeny, of which '*G.* *dentatus* is the prime example, comprise the suppression of the upward-growing flange present in the ontogeny of th2¹ in the primitive diplograptid pattern (Pattern A), the consequent J-shaped growth of the crossing canal of th2¹, and the late origin of th2² by a pattern of differentiation like that of distal thecae. Thus, this pattern has only two crossing canals and three primordial thecae, compared to the primitive pattern of three and four respectively. The Llanvirn–Llandeilo species that possess this pattern accordingly exhibit a relatively advanced proximal structure compared to their contemporaries among the Orthograptidae and Diplograptidae.

Text-fig. 13 indicates that the species group with Patterns H and I shares a common ancestry with Pattern B species. Since Pattern I is restricted to Silurian species, I have based the inference of common ancestry on characters shared between Patterns B and H. Pattern H astogeny is highly simplified and possesses few unique characters apart from the loss of the more complex features of other diplograptacean astogenies. Thus, establishing the sister group relations of Pattern H species poses a difficulty. The overall shape of the proximal end, as well as the ontogeny of th1², are like those in species with astogenetic Patterns E and F—both of which are also highly derived and simplified patterns. However, species with Patterns E and F primordial astogenies exhibit distinctive, derived features of the sicula or of its relationship to the colony that unambiguously ally them with the orthograptids or diplograptids and exclude any close relationship with Pattern H species. For instance, in the geniculograptids (Peiragraptinae, generic group 2), which possess a Pattern F astogeny, the sicula is extensively exposed on the obverse side of the colony and its aperture bears a pair of antivirgellar spines—all synapomorphies shared among the Peiragraptinae as a whole. In contrast, species with Pattern H retain the primitive conditions: the sicula is rapidly enclosed by th1² and th2¹ on the obverse side of the rhabdosome and its aperture does not bear antivirgellar spines. These are also still present in *C.* (*Diplacanthograptus*) *spiniferus* (the only species with a Pattern E astogeny in which the details of its course are known), but, once again, the sicula exhibits a suite of unique features: the metasacula is strongly deflected toward its dorsal side and exhibits a series of regularly spaced bands comprising condensed fuselli, while the prosacula is replaced by a set of rods

that unite to form the nema. These characters are shared with *C. (Climacograptus) bicornis* and other species with a Pattern D astogeny. Since this suite of synapomorphies appeared among the Climacograptinae prior to the derivation of the Pattern E astogeny, and since the species with a Pattern H astogeny lack all of these characteristic sicular features, the similarity between these highly simplified primordial astogenetic patterns must be analogous and must have been derived in parallel. Furthermore, $th2^1$ is commonly the dicalycal theca in Pattern H species, but all known Pattern F species are aseptate and no species of *Climacograptus* s.s. (whether with a Pattern D or E astogeny) is known to have a dicalycal theca earlier than $th2^2$.

The combination of a prosoblastic $th2^1$ that gives rise to $th2^2$ from its upward-growing segment, and which is *also* dicalycal, is found only in species with a Pattern H or a Pattern B astogeny. Additionally, a thecal form strikingly like that of the early glyptograptines of the *G. euglyphus* group is present in '*G. jaroslovi*' (Bouček). Contrary to the inexplicable thecal diagram given by Bouček (1973, text-fig. 36d), '*G. jaroslovi*' appears to exhibit a Pattern B proximal end structure. Given these resemblances, I conclude that *Glyptograptus* s.s. (but including members of the '*C. brevis*'-'*C. normalis*' and related lineages) is the sister group of the primitive, *Glyptograptus*-like, and Pattern B-bearing species (e.g. '*G. dentatus*' and '*G. jaroslovi*') grouped below as *Eoglyptograptus* gen. nov.

It is among species with a Pattern H astogeny that we at last encounter the diplograptaceans with glyptograptid thecae that are congeneric with *Diplograptus tamariscus* Nicholson, the type species of *Glyptograptus* Lapworth. The *Climacograptus*-like species of this group, however, are only homeomorphic with *C. bicornis* and not closely related to it, as discussed above. Přibyl's (1947) taxon *Paraclimacograptus*, with '*C. innotatus*' as its type, is available to accommodate those Silurian (and possibly Ordovician) glyptograptines with climacograptid thecae and prominent genicular flanges. However, it is unclear to what extent the other Silurian and Ordovician 'climacograptines' such as '*C. rectangularis*', '*C. normalis*', '*C. mohawkensis*', and '*C. brevis*' constitute a true clade separate from *Glyptograptus* (see Bulman 1963b, p. 413; 1970, p. V103). Among the many Llandoveryan glyptograptine species the distinction between *Glyptograptus* and '*Climacograptus*' is entirely arbitrary (see Rickards *et al.* 1977, p. 19). At the present time, it seems preferable to group all these species together under the genus *Glyptograptus* Lapworth. Detailed morphometric studies may help to delineate some useful and recognizable subclades within this complex array of structurally simple taxa.

Pattern I-bearing species, which comprise the Retiolitinae (including *Petalograptus* and *Cephalograptus*, as well as the 'retiolitids' themselves: see text-fig. 16) and the Dimorphograptinae, share with Pattern H-bearing species, the Glyptograptinae: 1, the propensity of the right lateral wall of the metatheca of $th1^1$ to be free of its protheca on the reverse side, and thus to form a free-standing edge, as in '*C. brevis*', or a broad reverse wall that extends on to the sicula, as in *Petalograptus* (see text-fig. 12A, B); 2, the tendency for the left lateral wall to enclose much or all of the descending portion of its protheca on its obverse side; and 3, the continued presence of the plesiomorphic dicalycal $th2^1$. The primordial astogenetic Patterns H and I characterize all of the biserial Silurian diplograptaceans with the exception of the retiolitines. Silurian species currently identified as *Diplograptus*, *Amplexograptus*, or *Orthograptus* will have to be either subsumed by *Glyptograptus* or *Petalograptus* or renamed if their heritage is to be properly reflected and justice done to the true magnitude of the Late Ordovician extinction. None possess the characteristic astogenies of their Ordovician homeomorphs. Obut (1949), Obut and Sobolevskaya (1968), and others have erected a number of genera based on these unique Llandoveryan glyptograptines and their phylogenetic significance needs to be established.

The retiolitines have an even more highly derived proximal end structure than the other mono-graptids. Since the early thecae and even the metasicula are wholly unsclerotized, apart from the stylized clathrium, it is hardly possible to compare their primordial astogeny with that of the non-retiolitid diplograptaceans. None the less, they too possess proximal end structures that ally them with a sister group—in this case *Petalograptus*. In their recent work on the retiolitines, Bates and Kirk (1984) demonstrated that several *Petalograptus* species, such as '*O. obuti*', possess an ancora.

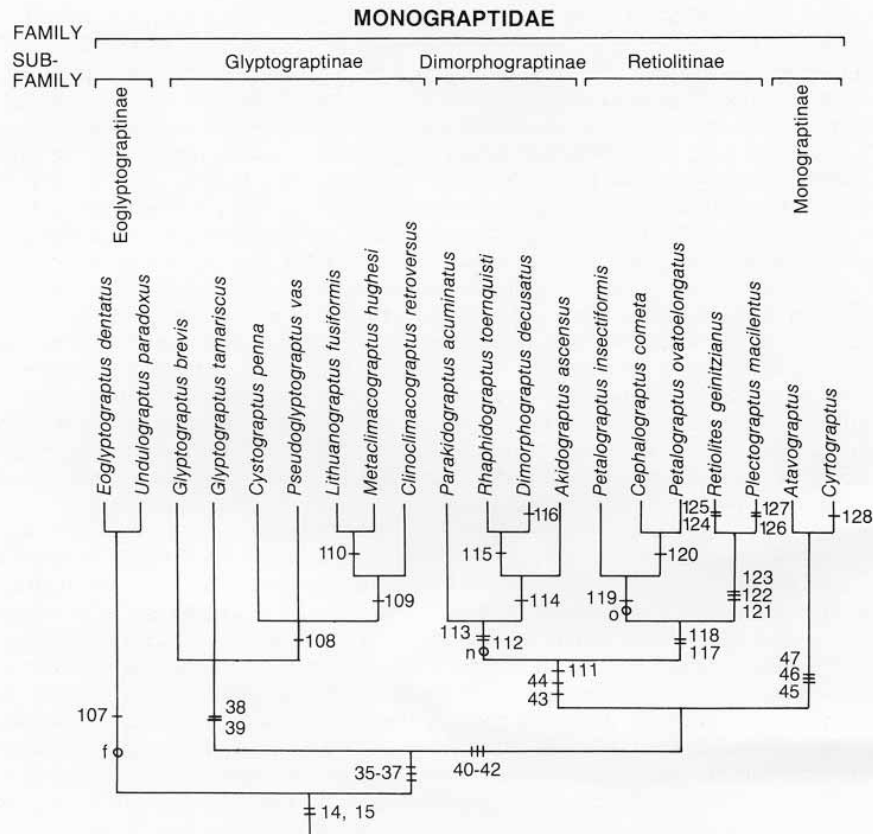

TEXT-FIG. 16. Cladogram and classification of the Monograptidae. Synapomorphies 1-61 as in text-fig. 13A; **107**, th^2 J-shaped and without upward growing flange in its prothecal ontogeny; **108**, thecal elongation to produce double sigmoidal curvature; **109**, undulatory median septum; **110**, thecal apertures hooded by overhanging genicular flanges; **111**, orthograptid thecae; **112**, strongly acicular proximal end with dorsal side of sicula free for nearly its entire length; **113**, metatheca of th^1 becomes upturned well above sicular aperture; **114**, metatheca of th^2 reduced; **115**, metatheca of th^2 absent but protheca retained; **116**, th^2 absent; **117**, thecae inclined at high angle to axis of rhabdosome and with everted aperture; **118**, th^1 and th^2 with concave ventral walls; **119**, rhabdosome aseptate; **120**, thecae elongate and with great overlap; **121**, ancora incorporated into thecal clathria; **122**, fusellar periderm reduced to clathria; **123**, metasicula suppressed; **124**, clathrial elements corresponding to edges of interthecal septa present; **125**, 'reticulum' that forms separate, lacinia-like mesh which encloses, but is free of, clathria along median region of rhabdosome; **126**, clathria lacks elements showing any clear correspondence with interthecal septa; **127**, reticulum entirely dependent on clathria; **128**, cladia present. Retained primitive character **f** as in text-fig. 13A; **n**, dicalyca th^2 ; **o**, fusellar periderm present.

The conformity between the complex structures of the *Petalograptus* ancora and the ancora of the Silurian retiolitids suggests that these structures are homologous. This relationship raises questions about the nature of the so-called clathria of these graptolites. If their ancora is derived phylogenetically not from the fusellum of the thecae, but rather from a lacinia-like set of rods that arise from the virgella independently of the thecae, then the retiolitine skeletal framework can hardly be considered a clathria in the same sense that it is among the Lasiograptinae or the Abrograptinae. This appears to be the case at least in '*O. obuti*', where the ancora produces a lacinia-like structure that grows upwards to enclose an otherwise non-retiolitid-like and fully sclerotized rhabdosome. In

any case, the morphogenesis of these retiolitine colonies must be quite different from that of the Lasiograptinae (including the archiretiolitids). Not only is the proximal end structure of the Ordovician retiolite-type diplograptaceans derived from that of *Orthograptus* and related taxa, but here the lacinia is developed primarily from bifurcated thecal spines and lateral spines located along the dorsal clathria, and is anchored to an otherwise normal set of virgellar and antivirgellar spines.

Text-fig. 16 presents the Monograptinae as a sister group to the Retiolitinae plus the Dimorphograptinae, with their Pattern I astogeny, because in all these taxa $th1^2$ is no longer a primordial theca. As discussed below, this relationship explains many of the troubling similarities between the Monograptinae and the Dimorphograptinae—similarities that are not accounted for in the phylogenetic hypotheses advanced by Rickards and Hutt (1970) and Rickards, Hutt and Berry (1977). It also provides insights into the significance of some of the unique features of the Monograptinae that previously did not appear to be directly related to their origins.

As Bulman (1970, pp. V108–V109) noted, the elimination of $th1^2$ from the astogenetic sequence has been a stumbling block to theories concerning the origin of the monograptine design. He pointed out that the suppression of the dicalycal theca is not sufficient to produce a monograptid rhabdosome and cited the partly monoserial species *Peiragraptus fallax* as an example. Indeed, the suppression of the dicalycal theca is not sufficient, but neither is its location or suppression of critical significance to this problem. Nevertheless, the structure of *P. fallax* is helpful in understanding the evolution of a fully monograptid rhabdosome.

In *P. fallax* the proximal end consists of three alternate thecae, $th1^1$, $th1^2$, and $th2^1$, after which the rhabdosome is uniserial. This condition, in which $th1^2$ is retained while $th2^2$ is lost, is not the consequence of the suppression of the second bud of the dicalycal theca. In no species with a Pattern G astogeny is $th2^1$ dicalycal; *A. beckeri* has a dicalycal $th3^1$ and this is the earliest dicalycal theca of any Pattern G species known to me. Furthermore, all of the advanced peiragraptine species to which *P. fallax* is most closely related are aseptate, e.g. *A. prominens* Barrass and *Paraorthograptus pacificus* (Ruedemann). The proximal end configuration of *Peiragraptus fallax* suggests that it is not the location or presence of a dicalycal thecae that is problematic. Rather, the cause of this proximally biserial and distally uniserial rhabdosome form appears to be the configuration of the highly conservative primordial thecae. Both this species and all others with a Pattern G astogeny possess three primordial thecae, and it is precisely these three that are retained in their primitive alternating form in *P. fallax*. $Th2^2$ may be the first theca to be suppressed because it is the first non-primordial theca. $Th1^2$ cannot be reoriented or eliminated until it is liberated from its role in the primordial astogeny. Following such liberation in the Pattern I astogeny, the metatheca of $th1^2$ is reduced and eventually eliminated from the astogeny of both the dimorphograptines and the monograptines. The dimorphograptines remain fundamentally biserial diplograptaceans, however, perhaps because of the diplograptid ontogeny of the sole primordial theca, $th1^1$, which they retained. The first theca includes a downward-growing prothecal segment in which a foramen for $th1^2$ develops. The dimorphograptines, with their uni-biserial architecture, appear not to have been involved in the ancestry of the monograptines. Indeed, Li (1985) has recently demonstrated that the early dimorphograptines (e.g. *D. elongatus* of the *P. acuminatus* and *C. vesiculosus* zones) have longer uniserial sections than do those of succeeding zones, suggesting that evolution in this group favoured the accumulation of more fully biserial rather than monoserial species.

The fully monograptid condition of the Monograptinae arose through the loss of the characteristic primordial features of $th1$. The morphogenesis of the sicula and the mode of origin of $th1$ reflect the loss of the primordial status of $th1$. In all of the Graptoloidea except the Monograptinae, the first theca arises through a resorption foramen. Among the Monograptinae a sinus forms in the aperture as the metatheca grows. The protheca of $th1$ crosses the virgella and then grows directly upward without any noteworthy ontogenetic specializations. This coincidence between the occurrence of a wholly unprecedented structural change in the sicula and the early ontogeny of $th1$ on the one hand, and the possession of a radically new rhabdosomal form on the other, could be unrelated to the acquisition of the monograptid condition but this is unlikely. The sicula is the most structurally and morphologically conservative portion of graptolite colonies. The resorption

foramen is plesiomorphic with respect to the entire Graptolithina and the nematophorous sicula, with a primordial th1, is plesiomorphic to the Graptoloidea. The shift from a resorption foramen did not involve the simple loss of that feature but, rather, required an alteration of metasicular ontogeny.

The fusellar morphology of the metasicula provides some information about the origins of the monograptine sicular ontogeny: the configuration of growth lines during the sinus and lacuna stages of porus formation are remarkably like the corresponding stages in the formation of the foramen for th1² in the descending protheca of th1¹ among other diplograptaceans. The metasicular fuselli arc out from the sicular profile and loop back distalward. They make contact with previous fuselli before reaching the virgella (e.g. Bulman 1970, fig. 48.9; Walker 1953, text-fig. 2). In this way the siculozoid formed a hooded foramen. The metasicula's contribution to the hood ceased when the next fusellus reached directly around to the virgella and so closed the open proximal end of the sinus. The th1 protheca arises unconformably from this hooded foramen. The configuration of its protheca and metatheca are like those of all subsequent thecae.

I propose that this similarity between the sicular structures and mode of origin of th1 in the Monograptinae and the structure of the protheca of th1¹ and mode of origin of th1² in glyptograptines is more than analogy—it reflects a common origin. The monograptid condition, like that of the other fundamentally distinct primordial astogenetic patterns among graptolites, appears to have arisen by an abrupt shift in the timing or coordination of a crucial event in the astogenetic sequence: by a kind of colonial heterochrony. Beginning with a primordial astogeny in which only th1¹ retained its specialized role in astogeny, as in Pattern I, the essential primordial feature of the protheca of th1¹ (the hooded foramen for th1²) was accelerated (displaced to an earlier stage in astogeny) into the ontogeny of the sicula, th1 was liberated from its role as a primordial theca and the previously fully biserial colony acquired a fully uniserial architecture.

Rickards *et al.* (1977, pp. 36–39) advanced the theory that the monograptines arose in a saltatory fashion within a dithyrial population of a glyptograptine species similar to *G. persculptus* in the *G. persculptus* Zone. Although a plausible suggestion, their theory lacked both a convincing mechanism and predictions by which it could be tested. Derived along a different route and based on a different logic, the theory I have outlined above postulates a similar mode of origin for the monograptines. It provides a mechanism for their proposed origin and a means of testing its explanatory power. It differs only in suggesting an ancestor with a Pattern I primordial astogeny like that of a *Petalograptus* or *Parakidograptus* species rather than the Pattern H-bearing glyptograptine favoured by Rickards *et al.*

Rickards and Hutt (1970) were unable to determine whether *Atavograptus ceryx* exhibited a descending portion in the ontogeny of th1 and whether this theca developed from a primary notch rather than a resorption foramen. If the theory presented above is correct, then suitable material should reveal the astogeny and sicula of *A. ceryx* to be fully monograptid. If it proves not to have a primary notch and a non-primordial th1, then the theory is wrong. The proposed relationships also imply that monoseriality of the monograptines and the dimorphograptines may be a parallelism that reflects the highly simplified character of the primordial astogeny of their common ancestor (an astogeny in which th1² was no longer a primordial theca), which established the necessary preconditions for a shift to uniserial colonies.

This mode of transformation from one primordial astogenetic pattern to another is not unique to the Monograptidae. The shift from a Pattern A to a Pattern G astogeny, for example, can be explained as the consequence of the acceleration of the upward-growing flange from the ontogeny of th2¹ (where it had fused with the crossing canal of th2¹ to form the pair of foramina through which the prothecae of th2¹ and th2² arose) into the ontogeny of th1² (where it fused with the downward-growing crossing canal of th1² to form the metatheca of th1² and the foramen from which th2¹ developed). The result is a simpler, less crowded proximal end in which there are now only three primordial thecae rather than four. The sequence of changes leading from a Pattern C to a Pattern D and thence to a Pattern E primordial astogeny (and likewise from Pattern G to Pattern F) also appears to have required only the relatively straightforward acceleration, *mutatis mutandis*,

to earlier astogenetic stages of the upward-growing flange of th₂¹ and the consequent reduction or suppression of the corresponding descending crossing canal. Such a shift in the timing of primordial astogenetic features, and particularly their transferral to an earlier stage in astogeny, appears to be the principal means by which the Diplograptacea achieved simplified astogenetic patterns.

Subfamily GLYPTOGRAPTINAE subfam. nov.

Diagnosis. Monograptids with glyptograptid to climacograptid or pseudoclimacograptid thecae; median septum straight to complexly folded and with a Pattern H primordial astogeny.

Generic group taxa. *Glyptograptus* Lapworth, *Climacograptus* Bulman and Rickards, *Cystograptus* Hundt, *Lithuanograptus* Paškevičius, *Metaclimacograptus* Bulman and Rickards, *Paraclimacograptus* Přibyl, *Pseudoglyptograptus* Bulman and Rickards [= ?*Comograptus* Obut and Sobolevskaya]. May include other taxa such as *Hedrograptus* Obut, but the phylogenetic status of these taxa remains to be established.

Genus GLYPTOGRAPTUS Lapworth, 1873, emend.

Type species. *Diplograptus tamariscus* Nicholson, 1868, Birkhill Shale, Southern Uplands, Scotland; Llandovery Series (*M. cyphus* to *M. turriculatus* zones).

Diagnosis. Species with glyptograptid to climacograptid thecae having relatively narrow geniculum and nearly straight supragenicular wall; proximal end generally narrow and fusiform, with strongly alternating thecae; generally septate with straight median septum and th₂¹ or some later theca dicalycal, but may be aseptate; sicula simple, generally short and broad, lacking antivirgellar spines.

Species included. Taxa assigned to this genus are too numerous to list but include: *G. euglyphus*, *G. sinuatus*, *G. tenuissimus*, *G. persculptus*, 'C.' *brevis*, 'C.' *rotundatus*, and 'C.' *scalaris*.

Discussion. The genus is here expanded to encompass the Ordovician and Silurian species formerly included in *Climacograptus* that possess a Pattern H astogeny (see discussion of Monograptidae, above), but restricted to apply only to those species with a Pattern H astogeny. This and other features distinguish the taxon from similar looking species in *Eoglyptograptus* gen. nov., *Hustedograptus* gen. nov., *Climacograptus*, and *Arnheimograptus* gen. nov. (see discussion of these taxa). *Glyptograptus* differs from *Paraclimacograptus* Přibyl in its lack of prominent genicular flanges.

Subfamily RETIOLITINAE Lapworth, 1873, emend.

Diagnosis. Monograptids with sharply acicular proximal end based on a Pattern I astogeny among forms with fully sclerotized proximal end or with ancora-based retiolitid astogeny; ancora common. Primitively with orthograptid thecae but elaborated to glyptograptid, climacograptid, or to a stylized clathrial framework.

Generic group taxa. Subfamily comprises three generic groups: Group 1 (petalograptids), *Petalograptus* Suess and *Cephalograptus* Hopkinson; Group 2 (retiolitids), *Retiolites* Barrande, *Pseudoplegmatograptus* Přibyl, *Sinostomatograptus* Huo Shih-Cheng, and *Stomatograptus* Tullberg; Group 3 (plectograptids), *Plectograptus* Moberg and Törnquist, *Agastograptus* Obut and Zaslavskaya, *Gothograptus* Frech, *Holoretiolites* Eisenack, *Paraplectograptus* Přibyl, and *Spinograptus* Bouček and Münch.

Genus PETALOGRAPTUS Suess, 1851, emend.

Type species. *Prionotis folium* Hisinger, 1837, Rastrites Shale?, Sweden; Llandovery Series (*M. leptotheca* and *M. convolutus* zones).

Emended diagnosis. Monograptids with orthograptid thecae disposed at a high to moderate angle to the colony axis and with extensive overlap. Thecal apertures everted. Thecae commonly with concave ventral walls that may lead to apertural isolation. Distally, thecal inclinations commonly

increase and the rhabdosome becomes broad and tabular. Ancora commonly present and some species exhibit additional spines on thecal apertures.

Species included. Representative species include *P. folium*, *P. ovatoelongatus*, *P. elongatus*, '*O.*' *eberleini*, '*O.*' *insectiformis*, and '*O.*' *mutabilis*.

Discussion. Genus is here expanded to include the Silurian species with a Pattern I astogeny formerly referred to '*Orthograptus*' [= *Dittograptus* Obut and Sobolevskaya].

Subfamily DIMORPHOGRAPTINAE Elles and Wood, 1908

Diagnosis. Monograptids with $th1^2$ reduced or absent, with proximally uniserial rhabdosomes. Length of the uniserial portion variable. Rhabdosome commonly septate with straight median septum. Astogeny of Pattern I. Sricula commonly with ancora.

Generic group taxa. *Dimorphograptus* Lapworth, *Akidograptus* Davies, *Parakidograptus* Le and Gei, *Rhaphidograptus* Bulman.

Discussion. In the light of studies by Li (1985) and Rickards *et al.* (1977), which suggest that several of the genera in this family are polyphyletic, and the several additional taxa that have been proposed for various species with different thecal shapes (e.g. *Bulmanograptus* Přibyl, *Agetograptus* Obut and Sobolevskaya, and *Metadimorphograptus* Přibyl) the phylogenetic status of the entire Dimorphograptinae needs to be re-examined.

Subfamily EOGLYPTOGRAPTIDAE subfam. nov.

Diagnosis. Archaic monograptids with glyptograptid to climacograptid thecae, straight to undulating median septum, and Pattern B primordial astogeny.

Generic group taxa. *Eoglyptograptus* gen. nov. and *Undulograptus* Bouček, 1973, emend.

Genus EOGLYPTOGRAPTUS gen. nov.

Type species. *Fucoides dentatus* Brongniart, 1828, Upper Lévis Shale, Point Lévis, Quebec; Whiterockian Series (*Isograptus* and *P. etheridgei* zones).

Diagnosis. Monograptids with glyptograptid thecae having a gentle geniculum located about half-way along the theca. Thecae overlap about one half their length and commonly bear cusped apertures. Narrow, gradually widening rhabdosomes are septate with a straight median septum. The dicalycal theca may be $th2^1$ or a later theca. The strongly asymmetric proximal end is broadly rounded and exhibits a Pattern B astogeny. $Th1^1$ may possess a subapertural spine or the proximal end may be without spines apart from the virgella.

Species included. '*G.*' *dentatus* Brongniart, '*Pseudoclimacograptus*' *jaroslovi* Bouček, and '*G.*' *cernuus* Jaanusson.

Discussion. Skevington's (1965, fig. 61a) illustration of the *E. dentatus* specimen, Ö1 1228, is inaccurate: the specimen does not possess a $th2^2$ crossing canal where shown on this figure. The illustrated structure is wholly incompatible with his fig. 62a and with Bulman's (1936, 1963a) wax model reconstructed from serial sections. Text-fig. 3j is a new illustration of Ö1 1228.

Eoglyptograptus gen. nov. differs from other *Glyptograptus*-like taxa principally in the form of its proximal end and primordial astogeny. Species of *Glyptograptus* sensu stricto lack the apertural cusps present on the thecae of *E. dentatus* and *E. cernuus* and exhibit a narrower and more fusiform proximal end based on a Pattern H astogeny. Among the Orthograptidae, species of *Arnheimograptus* gen. nov. resemble the eoglyptograptids in their rhabdosome form and proximal end shape, but possess a Pattern F primordial astogeny and an extensively exposed sricula with antivirgellar spines.

Genus UNDULOGRAPTUS Bouček, 1973, emend.

Type species. *Climacograptus paradoxus* Bouček, 1944 [= ?*C. pauperatus* Bulman, 1953], Šárka Formation, Krušná hora Mt. region, Bohemia; Llanvirn Series (lower *D. bifidus* Zone).

Emended diagnosis. Taxon here restricted to forms like the type species, which exhibits climacograptid thecae, a weakly undulating median septum, and a Pattern B astogeny (= *Undulograptus* Jenkins, 1980, *partim*).

Species included. If one accepts Bouček's (1973) determination that '*C.*' *pauperatus* is synonymous with the type species, this taxon is presently monotypic. '*C.*' *pauperatus* occurs in the *Ogygiocaris* Series, Norway and in the Seby Limestone, Öland; both occurrences are equated with the *D. murchisoni* Zone.

Discussion. The narrow proximal end and Pattern B astogeny of the type species is quite unlike those of *Oelandograptus austrodentatus* and congeners. Jenkins's (1980) expansion of Bouček's taxon to encompass these species was ill advised. However, Bouček (1973) also included several species in *Pseudoclimacograptus* (*Undulograptus*) that are indeed pseudoclimacograptines of the group *P.* (*Archiclimacograptus*), and that exhibit no close similarity to *U. paradoxus* other than their possession of an undulating median septum. *E. jaroslovi*, on the other hand, does seem to possess a similar proximal end structure but lacks the undulating median septum and has glyptograptid rather than climacograptid thecae. Thus, confusion about the scope of this taxon dates from its inception.

Subfamily MONOGRAPTINAE Lapworth, 1873

Diagnosis. Monograptids with fully uniserial stipes; some with cladia formed by secondary budding from a mature zooid or sicula; proximal end development highly simplified, having no primordial thecae; th1 grew upwards from a primary porus produced by the metasicula during its ontogeny.

Discussion. Rickards *et al.* (1977) presented a detailed study of monograptid phylogeny which indicated that the divisions Monograptidae and Cyrtograptidae of the Monograptina (see Bulman 1955, 1970) are not phyletically meaningful units. They did not present an alternative classification, however. Thus, the systematic subdivision of the Monograptinae based upon the group's evolutionary history remains to be accomplished.

MACROEVOLUTIONARY PATTERNS

My intention here has been to present a phylogenetic classification of the Diplograptacea. Accordingly, consideration of their evolutionary history forms an integral part of this endeavour. It is not primarily my intention to review the history of the classification (but see Rigby 1986) or to speculate about the causes that may have underlain diplograptacean macroevolutionary patterns. Considerable work remains to be conducted in deciphering the details of this history. Nevertheless, a number of large scale features of diplograptacean phylogeny are now apparent. These have implications for both systematic practice and for future studies of graptolite colonial evolution.

The course of graptolite evolution has generally been traced on the basis of similarity in thecal characters and in the disposition of the stipes, following the suggestions of Nicholson and Marr (1895; see also Bulman 1970, p. V102). Neither when Nicholson and Marr wrote nor at any time since has there been any compelling biological justification for this preference among the suite of characters available for study in flattened graptolites. Rather, the demands of pragmatism, combined with the attractively anti-Darwinian phylogenies that the method generated, led to a general acceptance of Nicholson and Marr's proposals among their contemporaries. The major works on graptolite phylogeny (e.g. Elles 1898, 1922; Bulman 1933*a, b*, 1936; Bouček and Přibyl 1951) and systematics (e.g. Elles and Wood 1901-1918; Ruedemann 1904, 1908; Mu 1950) followed their recommendations. The conception of graptolite evolutionary history that subsequently emerged was one characterized by a confusing array of parallel trends, each leading in Lamarkian fashion

to the progressive improvement of the lineage. These trends manifested themselves not only in astoundingly similar colony designs within independent lineages but also in their often contemporaneous appearance (Elles 1898, 1922; Ruedemann 1904; Bulman 1933*b*; Rickards *et al.* 1977). Within this framework, primordial astogeny has been seen as simply another of the many features of graptoloid colonies that underwent extensive parallel change. Thus, Bulman (1933*a*, p. 2) while discussing Elles's developmental types, cautioned that '... they represent simply grades of evolution, probably reached or passed through quite independently in many different lineages. What is here assembled as a purely morphological series, without strict reference to phylogeny, is believed to represent an 'orthogenetic' trend, comparable with the stipe reduction trend and others described by Elles. ...'

Graptolite evolutionary history became one of the prime examples of orthogenesis (Bulman 1933*b*). Urbanek (1959, p. 326) and others have expressed a similar attitude with regard to the phylogenetic significance of astogenetic similarities. Although Bulman (1960, 1963*a, b*) later retreated from his statements on the importance of orthogenesis as an explanation for the observed trends, the present graptoloid classification remains one that is conceptually more compatible with Osborn's theory of aristogenesis than with Darwinian theory. This systematic history, combined with the inherent difficulty of producing a phylogenetic classification of these organisms from their often inadequately preserved and incomplete remains (see Bulman 1963*b*, pp. 413–416) has prevented the establishment of an integrated graptoloid systematics that is in step with both the group's probable evolutionary history and with contemporary evolutionary thought.

The results of the present studies of diplograptacean astogeny and thecal form show that graptolite evolution was strikingly directional and exhibited distinct phases. The major diplograptacean clades were founded through apparently rapid structural reorganizations. The Diplograptacea differ from all other virgellinids in a substantial suite of features involving characters of the primordial astogeny, thecal form, and rhabdosome architecture. The nature of these structural changes, like those that occurred in the transitions from one primordial astogenetic pattern to another (such as from Pattern D to Pattern E, or from Pattern A to Pattern C), indicate that they were not gradual transitions made through a series of intermediate steps. Rather, they were achieved abruptly over a short interval of time (as in a single allopatric speciation event) compared to the millions of years over which they remained stable. This is also illustrated by the total lack of any preserved intermediates between diplograptaceans and non-diplograptaceans (despite nearly ninety years of searching) or between the groups of species characterized by the nine diplograptacean astogenetic patterns.

Following several of these rapid structural reorganizations (as in the case of the Orthograptidae, following the origin of the Pattern G astogeny), the new clade apparently underwent an evolutionary radiation. During its radiation the clade's members achieved a substantial diversity of thecal form and colony design, often exhibiting close analogy with species of other clades. The radiations of the Orthograptidae and the advanced climacograptines in the late Llandeilo and early Caradoc appear to have coincided with the waning of their predecessors among the primitive diplograptaceans (particularly *Oelandograptus* gen. nov. and *Hustedograptus* gen. nov.) and among the pseudoclimacograptids and diplograptines (see text-fig. 17). The appearance is one of a relay in which a dominant and diverse clade or set of clades is succeeded by another set which is itself succeeded. Hence, the faunas of the late Arenig to late Llandeilo were dominated by the archaic diplograptids (the Diplograptidae and, to a lesser degree, *Oelandograptus* and *Hustedograptus*). The late Llandeilo to latest Ashgill witnessed the proliferation of the advanced Orthograptidae, Climacograptinae (especially in the form of *Orthograptus*, *Amplexograptus*, and *Climacograptus*), and the Dicranograptidae. Following the near total extinction of diplograptaceans the Monograptidae underwent an explosive evolutionary diversification in the Llandovery. These intervals of successive clade dominance are more or less equivalent to the diplograptid subfaunas that Bulman described (1970, p. V99).

In the course of these three successive major radiations, homeomorphism arose in thecal form and rhabdosome architecture with a bewildering frequency. Furthermore, this pattern of radiations

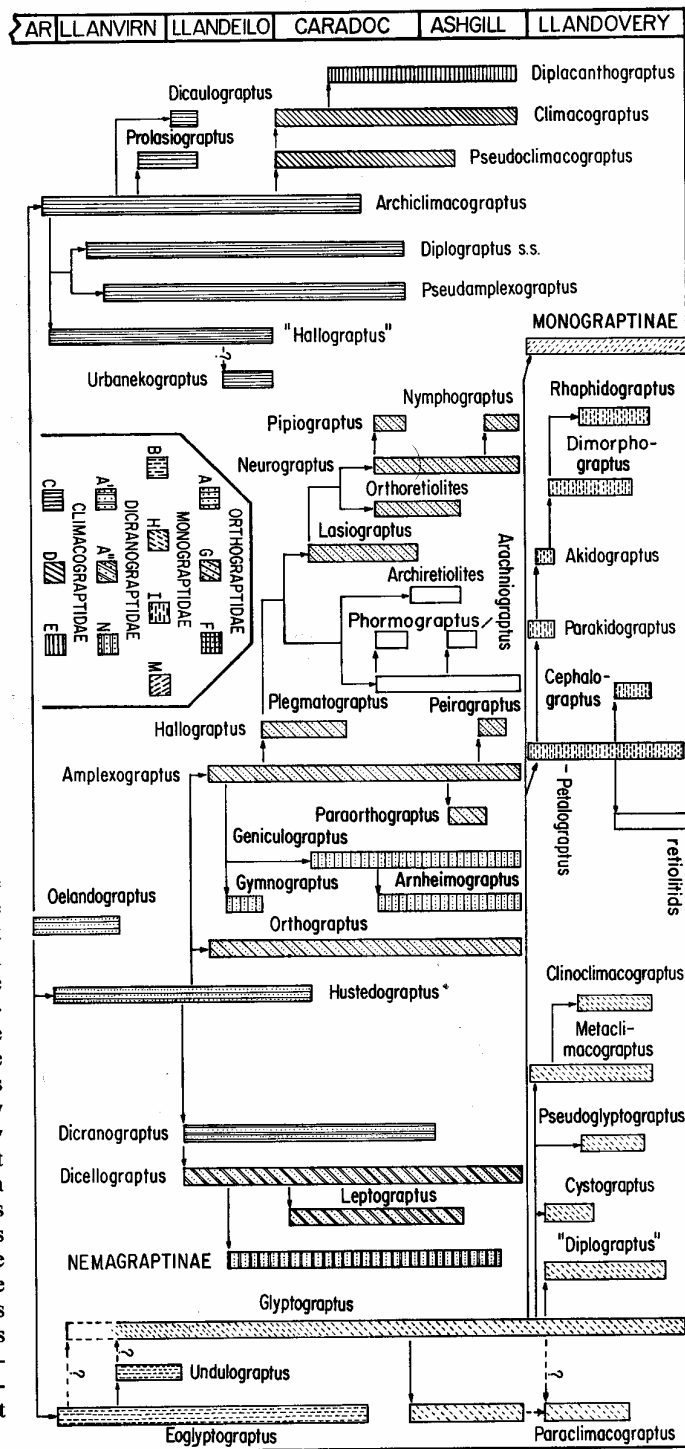

TEXT-FIG. 17. Evolutionary tree showing pattern of descent among the generic group taxa of the Diplograptacea in the interval of the upper Arerig to the base of the Wenlock Series. The nemagraptids and retiolitids are shown as family group taxa because of the remaining uncertainty about evolutionary relationships within them. The relationships among the generic group taxa of the Monograptinae are beyond the scope of the present study. Patterning within the range bars of each taxon indicates the astogenetic pattern exhibited by its constituent species and its family membership according to the inset key. The absence of patterning in range bars among the archiretiolitids (Orthograptidae) and retiolitids (Monograptidae) corresponds to the highly stylized clathrial architecture of these taxa that consequently does not fit within the astogenetic patterns defined herein. The plotted stratigraphic ranges of the taxa are approximate due to uncertainty about their species membership.

and rampant homeomorphism was not confined to the Diplograptacea. A number of authors (but especially Cooper and Fortey 1982) have recently completed work on the Arenig graptoloids that has revealed a surprisingly complex history. Early Arenig (Bendigonian Stage) faunas are dominated by *Pendiograptus* and an early proliferation of *Pseudophyllograptus* species. These are succeeded in the Chewtonian to early Castlemainian (Ca1) by pendent didymograptids (mostly *D. (Didymograptellus)* with an isograptid primordial astogeny) and *Phyllograptus* sensu stricto. Later in the Castlemainian, as the isograptids begin their main radiation, the pendent didymograptids vanish and *Phyllograptus* is succeeded by a second radiation of *Pseudophyllograptus*. Finally, there occurs the now well known sudden re-emergence, just prior to the beginning of the Darriwilian, of pendent didymograptids in the form of *D. (Didymograptus)*. This time, however, the rhabdosomes of these 'tuning fork' graptolites appear to be based for the most part on an *artus*-type primordial astogeny (see Cooper and Fortey 1983). To what degree this seemingly endless playing out of variations on a few themes reflects the action of either adaptive or constructional constraints (producing convergence), or channelling by historical constraints (leading to parallelisms) is an important area for further research—an area that may shed as much light on the processes of evolution as on the palaeobiology of graptoloids.

The nature of the causal connection, if any, between the waxing of one clade and the waning of another is unknown. This issue is likely to be intimately related to the source of the overall directional history of diplograptacean evolution. Ostensibly, their history exhibits a strong birth-bias in favour of more simplified astogenetic patterns. Following the establishment of the superfamily and the Pattern A primordial astogeny, ten of the eleven transitions to new primordial astogenetic patterns among the three lineages of fully scandent diplograptaceans (including the transitions to the clathrial astogenies of the archiretiolitids and retiolitids) resulted in astogenies less complex than the patterns that preceded them. (Relative complexity may be gauged by comparing the number of crossing canals and primordial thecae, as well as the mode of thecal construction, *vis.* the 'direct' growth pattern of the ontogeny of th1² in Pattern F compared to the 'indirect' mode of construction seen in Pattern G.) Only Pattern C is no simpler than its predecessor, Pattern A, but neither is it more complex. Furthermore, this trend toward greater astogenetic simplicity affected all three of the dominant Ordovician families: the Orthograptidae, Diplograptidae, and Monograptidae. Accepting the cladogenetic history depicted in text-fig. 13A, the Dicranograptidae underwent little change in primordial astogenetic structure during their range, except to give rise to the Nemaograptinae with their right-handed origin of th1². Transitions to astogenetic patterns of greater complexity either did not occur among the diplograptaceans or were so unsuccessful that they left no known record. Thus, the source of the variance that underlay the directional trends in astogeny and colonial architecture of the Diplograptacea was strongly channelled by directed speciation. Apart from the observation that loss of complexity is in some way 'easier' to achieve than is an increase in complexity (consider the host of extant albino creatures, from cave crickets and white rabbits to the Indian pipe, *Monotropa uniflora*, and the multitude of independent paths by which they arrived at this lack of pigmentation), we have only speculative answers to the question of why this bias should exist. Nevertheless, I am convinced by the frequent coincidence of a radiation in thecal form and an increase in the clade's diversity with the origin of a new, less complex astogeny that these astogenetic changes were associated with a selective advantage in favour of graptolites with a simplified pattern.

Differential rates of origination or extinction, or both, may also have contributed to the observed replacement of clades with a complex astogeny by clades with a less complex astogeny. During the course of diplograptacean evolution the changes in character distribution that accompanied the astogenetic trends involved characters for which variance existed only at the clade level. It is now clear that, phenomenologically at least, these trends seem to be the result of sorting among clades.

TABLE 2. Key to the identification of diplograptid astogenetic pattern on the basis of features visible in mature rhabdosomes well preserved in semi- or full relief, or in isolated preparations. These features are not a substitute for the study of isolated growth stages but are *guides* to the distinctive features of the modal proximal-end architecture associated with each astogenetic pattern. Sketches in the panels labelled II to VIII provide illustrations, in otherwise similar rhabdosomes, of the contrasting features under consideration in the corresponding key statement. For example, statement II asks the user to decide whether or not the prothecae of $th2^1$ and $th2^2$ arise as a symmetrical pair from the descending portion of the crossing canal of $th2^1$; the sketches in panel II illustrate proximal ends with a paired and an unpaired $th2^1$ and $th2^2$. Abbreviations: a, apertural thecal spine; av, antivirgellar spines on sicular aperture; m, mesial thecal spine; v, virgella. Diagonal or horizontal ruling highlights the theca or thecae that are the focus of comparison; vertical ruling highlights the sicula.

<p>I. Descending $Th2^1$ crossing canal is...</p> <p>a) visible.....II</p> <p>b) not visible.....IV</p>	<p>II</p> <p>Pattern A Pattern B</p>
<p>II. The $Th2^1$ & $Th2^2$ prothecae...</p> <p>a) arise as a symmetrical pair from $Th2^1$ crossing canal.....III</p> <p>b) arise separately & are not symmetrical.....Pattern B¹</p>	<p>III</p> <p>Pattern A Pattern C</p>
<p>III. Descending $Th2^1$ crossing canal...</p> <p>a) closely approaches $Th1^1$ or sicular aperture, generally on the $Th1^1$ - side of the rhabdosome median plane.....Pattern A²</p> <p>b) is visible as oval or diamond-shaped patch near median plane.....Pattern C³</p>	<p>IV</p> <p>Pattern A Pattern B</p>
<p>IV. Dorsal margin of sicular aperture...</p> <p>a) lacks antivirgellar spines.....VI</p> <p>b) possesses antivirgellar spines.....V</p>	<p>V</p> <p>Pattern A Pattern B</p>
<p>V. In obverse view, $Th1^1$ is...</p> <p>a) broadly "U" or "V" shaped with a gap between $Th1^1$ metatheca and the region of its protheca from which $Th1^2$ arises; gap filled by the $Th2^1$ protheca.....Pattern G⁴</p> <p>b) narrowly "U" shaped with metatheca pressed against the region of its protheca from which $Th1^2$ arises.....Pattern F⁵</p>	<p>VI</p> <p>Pattern A Pattern B</p>
<p>VI. $Th1^2$...</p> <p>a) is tubular & forms a wide evenly rounded arch across reverse side of the sicula, concentric to an expanded $Th2^1$ protheca.....Pattern D⁶</p> <p>b) has expanded, delta-shaped protheca from which $Th2^1$ arises across a narrow transverse unconformity.....VII</p>	<p>VII</p> <p>Pattern A Pattern B</p>
<p>VII. In obverse view, the sicula is...</p> <p>a) straight.....VIII</p> <p>b) strongly deflected toward its dorsal side & with a prominent virgella crossing the sicular aperture.....Pattern E⁷</p>	<p>VIII</p> <p>Pattern A Pattern B</p>
<p>VIII. In obverse view, sicula is...</p> <p>a) enclosed by $Th2^2$ & $Th2^1$ at level of the $Th1^1$ aperture.....Pattern H⁸</p> <p>b) exposed for most or all of its length.....Pattern I⁹</p>	<p>VI</p> <p>Pattern D</p> <p>VII</p> <p>Pattern H</p> <p>VIII</p> <p>Pattern E</p> <p>IX</p> <p>Pattern H</p> <p>X</p> <p>Pattern I</p>

APPENDIX

Application of classification to non-isolated graptolites

The circumstances described above make a thorough study of the evolutionary history of graptolites essential and justify a revision of their classification, despite the temporary hardship it may impose in the day to day practice of classification. Furthermore, I am confident that, with patience and attention given to the descriptions and figures provided here, most well-preserved flattened and semi-relief graptolite specimens can be placed within the new taxonomic system.

There are several features of the present situation that should ease the application of this classification to non-isolated material. First, although the diplograptacean astogenetic patterns initially could only be recognized through the study of isolated graptolite growth stages, now that they have been defined it is clear that each primordial astogenetic pattern exhibits a number of reliable morphological correlates visible in well-preserved, semi-relief, and flattened, mature specimens. Table 2 presents a key to these features and their correspondence with the diplograptacean astogenies. Given a working knowledge of the diplograptacean astogenetic patterns, it is possible to recognize many of their distinctive features in the flattened growth stages and sub-mature rhabdosomes that generally accompany fully developed colonies on shale surfaces. This is especially true if the age of the specimens at hand is known. Since many of the new and redefined taxa have shorter stratigraphic ranges than the previous form genera, this knowledge can be used to considerably narrow the range of possible astogenetic patterns that a species might possess (see text-fig. 17).

Secondly, scientists with the good fortune to have among their collections material preserved in semi- or full relief should begin the process of re-examining and re-illustrating the proximal ends and growth stages of the species so represented. Through the publication of such studies the list of species with known astogenetic patterns (Table 1) can be augmented. Although Table 1 does not include a majority of diplograptacean species, it nevertheless does represent a broad spectrum of diplograptacean diversity. By the association of morphologically similar but less well-preserved species with those in Table 1, the new classification can be extended to these other species.

Thirdly, the present situation is similar in many respects to the continuing reorganization of conodont form taxonomy. An interim device, like that used by conodont workers, can be employed in cases where the astogenetic pattern, and hence the generic classification, of a particular species is uncertain: where the generic affiliations of a species are ambiguous or unknown, the species name can simply be combined with a name corresponding to one of the traditional diplograptacean form-taxa, e.g. '*Diplograptus*' *compactus* (with the generic name enclosed in quotation marks to indicate that the name is being used as a form-taxon rather than in its phylogenetic sense). In cases where uncertainty about the generic assignment remains, but where the author considers it probable that the assignment of a species to a particular phylogenetic taxon is correct, this may be indicated as *Amplexograptus?* *arctus*. With these conventions, authors should be able to describe any diplograptacean fauna that is well enough preserved to support specific identification.

Finally, note that this revision only affects genera and higher taxonomic units. Astogenetic features are seldom of importance in the definition of graptolite species: not because astogeny is non-adaptive or inconsequential to the biology of the species, but because little variance in astogeny exists at this level in the taxonomic hierarchy. Thus, individual species will be identified as before and their use in biostratigraphy will remain unchanged.

Acknowledgements. The present study is part of a project begun as my doctoral dissertation at Harvard University. I thank Mr Anton Kearsley for his willingness to discuss work in progress on *Orthograptus* and diplograptacean systematics, and also Drs Anthony Arnold, Roger Cooper, Peter Crowther, Stan Finney, Richard Fortey, Valdar Jaanusson, Michael Melchin, John Riva, and Henry Williams for their discussions of some of the ideas and data presented, and their willingness to share their own ideas and data with me. I also thank Drs Jaanusson, Barrie Rickards, and Isles Strachan for their help and for allowing me to examine collections of isolated, three-dimensionally preserved graptolites in the collections of the Naturhistoriska Riksmuseet, Sedgwick Museum, Cambridge, and the University of Birmingham, respectively. I thank my dissertation advisor, Dr Steven J. Gould, for guidance and encouragement. My dissertation research was supported by National Science Foundation Dissertation Improvement Grant EAR 8115100 and by grants from the Department of Geological Sciences, Harvard University and the Royal Society of London.

REFERENCES

- ALBERSTADT, L. P. 1973. Articulate brachiopods of the Viola Formation (Ordovician) in the Arbuckle Mountains, Oklahoma. *Bull. Okla. geol. Surv.* **117**, 1-90.
- BARRASS, R. 1954. Graptolites from Anticosti Island. *Q. Jl. geol. Soc. Lond.* **110**, 55-75.
- BATES, D. E. B. and KIRK, N. H. 1984. Autecology of Silurian graptoloids. *Spec. Pap. Palaeont.* **32**, 121-139, pls. 1-3.
- BERRY, W. B. N. 1964. The middle Ordovician of the Oslo region. No. 16. Graptolites of the *Ogygiocaris* Series. *Norsk. geol. Tidsskr.* **44**, 61-170.
- BOUČEK, B. 1973. *Lower Ordovician graptolites of Bohemia*, 182 pp., 24 pls. Czechoslovak Academy of Science, Academic Press, Prague.
- and PŘIBYL, A. 1951. Taxonomy and phylogeny of some Ordovician graptolites. *Bull. Int. Acad. tchèque Sci.* **52**, 265-283.
- BULMAN, O. M. B. 1932. On the graptolites prepared by Holm, Pt. 1. Certain diprionid graptolites and their development. *Ark. Zool.* **24A** (8), 1-46, quarto pls. 1-9.
- 1933a [dated 1932]. Notes on the evolution and morphology of certain graptoloids. *Ibid.* (13), 1-37.
- 1933b. Programme-evolution in the graptolites. *Biol. Rev.* **8**, 311-334.
- 1936. On the graptolites prepared by Holm, Pt. 7. The graptolite fauna of the *Orthoceras* Limestone of Hälludden, Öland and its bearing on the evolution of the lower Ordovician graptolites. *Ark. Zool.* **28A** (17), 1-107, quarto pls. 1-4.
- 1945-1947. Monograph of the Caradoc (Balclatchie) graptolites from the limestones in Laggan Burn, Ayrshire. *Palaeontogr. Soc. [Monogr.]*, 78 pp., 10 pls.
- 1953. Some graptolites from the *Ogygiocaris* series (4ax) of the Oslo district. *Ark. Miner. Geol.* **1**, 509-518.
- 1960. Some morphologically intermediate genera in graptolite phylogeny. *21st. Int. geol. Congr. Norden, sect. 22*, 65-70.
- 1962. On the genus *Amplexograptus* Lapworth, Elles & Wood. *Geol. Mag.* **99**, 459-467.
- 1963a. On *Glyptograptus dentatus* (Brongniart) and some allied species. *Palaeontology*, **6**, 665-689.
- 1963b. The evolution and classification of the Graptoloidea. *Q. Jl. geol. Soc. Lond.* **119**, 401-418.
- 1968. Graptolithina. In MOORE, R. C. *et al.* Developments, trends and outlooks in paleontology. *J. Paleont.* **42**, 1327-1377.
- 1970. *Graptolithina with sections on Enteropneusta and Pterobranchia*. In TEICHERT, C. (ed.). *Treatise on Invertebrate Paleontology, Part V*, (2nd edn.), 163 pp. Geological Society of America and University of Kansas Press, Boulder, Colorado and Lawrence, Kansas.
- and RICKARDS, R. B. 1968. Some new diplograptids from the Llandovery of Britain and Scandinavia. *Palaeontology*, **11**, 1-15.
- CHURKIN, M. and CARTER, C. 1970. Early Silurian graptolites from southeastern Alaska and their correlation with graptolite sequences in North America and the Arctic. *Prof. Pap. U.S. geol. Surv.* **653**, 1-51.
- COOPER, R. A. and FORTEY, R. A. 1982. The Ordovician graptolites of Spitsbergen. *Bull. Br. Mus. nat. Hist. (Geol.)*, **36**, 157-302, 6 pls.
- 1983. Development of the graptoloid rhabdosome. *Alcheringa*, **7**, 201-221.
- ELLES, G. L. 1898. Graptolite faunas of the Skiddaw Slates. *Q. Jl. geol. Soc. Lond.* **54**, 463-539.
- 1922. The graptolite faunas of the British Isles. A study in evolution. *Proc. Geol. Ass.* **33**, 168-200.
- and WOOD, E. M. R. 1901-1918. A Monograph of British graptolites. *Palaeontogr. Soc. [Monogr.]*, clxxi + 539 pp., 52 pls.
- FINNEY, S. C. 1980. Thamnograptid, dichograptid and abrograptid graptolites from the middle Ordovician Athens Shale of Alabama. *J. Paleont.* **54**, 1184-1208.
- 1985. Nemaograptid graptolites from the middle Ordovician Athens Shale, Alabama. *Ibid.* **59**, 1100-1137.
- FORTEY, R. A. and COOPER, R. A. 1986. A phylogenetic classification of the graptoloids. *Palaeontology*, **29**, 631-654.
- and JEFFERIES, R. P. S. 1982. Fossils and phylogeny—a compromise approach. In JOYSEY, K. A. and FRIDAY, A. E. (eds.). Problems of phylogenetic reconstruction. *Spec. Vol. Syst. Ass.* **21**, 197-234.
- GOULD, S. J. 1977. *Ontogeny and phylogeny*, 501 pp. Harvard University Press, Cambridge, Mass.
- HOLM, G. 1895. On *Didymograptus*, *Tetragraptus* and *Phyllograptus*. *Geol. Mag.* **32**, 433-441, 481-492, pls. 13 and 14.
- HUTT, J., RICKARDS, R. B. and SKEVINGTON, D. 1970. Isolated Silurian graptolites from the Bollerup and Klubbedden Stages of Dalarna, Sweden. *Geologica Palaeont.* **4**, 1-23.

- JANUSSON, V. 1960. Graptoloids from the Ontikan and Viruan (Ordovician) limestones of Estonia and Sweden. *Bull. geol. Instn Univ. Upsala*, **38**, 289-366.
- JENKINS, C. 1980. *Maendrograptus schmalenseei* and its bearing on the origin of the diplograptids. *Lethaia*, **13**, 289-302.
- KEARSLEY, A. 1982. Morphology and systematics of species of *Orthograptus* Lapworth. *Newsl. Grap. Wkg Grp Int. Paleont. Ass.* **3**, 10-13.
- 1985. A new phylogeny of diplograptid graptoloids, and their classification based on proximal and thecal construction. *Ibid.* **6**, 8-22.
- LAPWORTH, C. 1873. On an improved classification of the Rhabdophora. *Geol. Mag.* **10**, 500-504, 555-560.
- 1876. The Silurian System in the south of Scotland. In ARMSTRONG, J., YOUNG, J. and ROBERTSON, D. *Catalogue of Western Scottish fossils*, xxiii + 164 + 24 pp., 4 pls. Blackie & Son, Glasgow.
- 1877. On the graptolites of County Down. In *Systematic lists illustrative of the flora, fauna, palaeontology and archaeology of the North of Ireland by the members of the Belfast Naturalists Field Club*, Vol. 1, Append. IV, 126-144, pls. v-vii.
- 1880. On new British graptolites. *Ann. Mag. nat. Hist.* (ser. 5), **5**, 149-177, pls. 4 and 5.
- LI JI-JIN. 1985. On the origin of dimorphograptids. In BJERRESKOV, M. and STOUGE, S. (eds.). *Abstr. Third Int. Grap. Conf. Copenhagen, 1985*, 57.
- MITCHELL, C. E. 1981. Preliminary morphometric studies of astogeny and colony form in *Climacograptus* Hall and the incorporation of astogenetic data into phylogenetic hypotheses. *Prog. Abstr. Second Int. Grap. Conf. Cambridge, 1981*, 19.
- 1986. Morphometric studies of *Climacograptus* Hall and the phylogenetic significance of astogeny. In HUGHES, C. P. and RICKARDS, R. B. (eds.). *Palaeoecology and biostratigraphy of graptolites. Spec. Publ. geol. Soc.* **20**, 119-129.
- and CARLE, K. J. 1986. The nematularium of *Pseudoclimacograptus scharenbergi* (Lapworth) and its secretion. *Palaeontology*, **29**, 373-390, pls. 28 and 29.
- MU EN-ZHI (= MU, A. T.). 1950. On the evolution and classification of graptolites. *Geol. Rev. Beijing*, **15**, 171-183.
- et al. 1974. In *A handbook of the stratigraphy and paleontology in South-west China*, (ed. Nanjing) Inst. Geol. and Paleontol., Academia Sinica. Science Publ. Co. Nanjing, 154-221. [In Chinese.]
- MÜLLER, A. H. and SCHAUER, M. 1969. Über schwebenrichtungen bei Diplograptidae (Graptolithina) aus dem Silur. *Freiberger ForschHft.* **C245**, 5-26.
- NICHOLSON, H. A. and MARR, J. E. 1895. Notes on the phylogeny of the graptolites. *Geol. Mag.* **42**, 529-539.
- OBUT, A. M. 1949. Polevoi atlas rukovodyashchikh graptolitov verkhnego silura Kirgizskoi SSR. [Field atlas of leading graptolites of the Upper Silurian of Kirgiz SSR.] *Trudy geol. Inst., Frunze*, **1949**, 1-56, pls. 1-7.
- and SOBOLEVSKAYA, R. F. 1968. In OBUT, A. M., SOBOLEVSKAYA, R. F. and MERKUREVA, A. P. Graptolity Llandoveri v kernakh burovykh skvazhin Noril'skogo rayona. [Graptolites of the Llandoveri in core samples from boreholes in the Norilsk District.] *Trudy Inst. Geol. Geofiz. Sib. Otd.* 1-126, pls. 1-35.
- PŘIBYL, A. 1947. On the classification of the genus *Climacograptus* Hall, 1865. *Bull. int. Acad. tchèque Sci.* **48**, 1-12, pls. 1 and 2.
- RICKARDS, R. B. and HUTT, J. E. 1970. The earliest monograptid. *Proc. geol. Soc. Lond.* **1663**, 115-119.
- and BERRY, W. B. N. 1977. Evolution of the Silurian and Devonian graptoloids. *Bull. Br. Mus. nat. Hist. (Geol.)*, **28**, 5-120, 6 pls.
- and KOREN, T. N. 1974. Virgellar meshworks and sicular spinosity in Llandoveri graptoloids. *Geol. Mag.* **111**, 193-204.
- RIGBY, R. 1986. Critique of graptolite classification, and a revision of the Suborders Diplograptina and Monograptina. In HUGHES, C. P. and RICKARDS, R. B. (eds.). *Palaeoecology and biostratigraphy of graptolites. Spec. Publ. geol. Soc.* **20**, 1-13.
- RIVA, J. 1976. *Climacograptus bicornis bicornis* Hall, its ancestors and likely descendants. In BASSETT, M. G. (ed.). *The Ordovician System*, 589-619. Proceed. Paleont. Symp. Birmingham, 1974, Univ. Wales Press, Nat. Mus. Wales, Cardiff, Wales.
- RUEDEMANN, R. 1904. Graptolites of New York, Pt. I. Graptolites of the lower beds. *Mem. N.Y. St. Mus. nat. Hist.* **7**, 457-803, pls. 1-17.
- 1908. Graptolites of New York, Pt. II. Graptolites of the higher beds. *Ibid.* **11**, 1-583, pls. 1-31.
- SKEVINGTON, D. 1965. Graptolites from the Ontikan limestones (Ordovician) of Oland, Sweden. II. Graptoloidea and Graptovermida. *Bull. geol. Instn Univ. Upsala*, **43**, 1-74.
- SKOGLUND, R. 1963. Uppermost Viruan and lower Harjuan (Ordovician) stratigraphy of Västergötland and lower Harjuan graptolite faunas of Central Sweden. *Ibid.* **42**, 1-55.

- STRACHAN, I. 1974. Further isolated graptolites from the Ordovician of Girvan. In RICKARDS, R. B., JACKSON, D. E. and HUGHES, C. P. (eds.). Graptolite studies in honour of O. M. B. Bulman. *Spec. Pap. Palaeont.* **13**, 99-105.
- WALKER, M. O. 1953. The development of *Monograptus dubius* and *Monograptus chimaera*. *Geol. Mag.* **90**, 362-373.
- WIMAN, C. 1895. Über die graptoliten. *Bull. geol. Instn Univ. Upsala*, **2**, 239-316, pls. 9-15.
- URBANEK, A. 1959. Studies on graptolites, II. On the development and structure of the graptolite genus *Gymnograptus* Bulman. *Acta palaeont. pol.* **4**, 279-336, pls. 1, 2.
- 1973. Organization and evolution of graptolite colonies. In BOARDMAN, R. S., CHEETHAM, A. H. and OLIVER, JR., W. A. (eds.). *Animal colonies: development and function through time*, 441-514. Dowden, Hutchinson and Ross, Stroudsburg, Penn.

Typescript received 26 March 1986

Revised typescript received 18 September 1986

CHARLES E. MITCHELL
Department of Geological Sciences
State University of New York at Buffalo
4240 Ridge Lea Road
Amherst, New York 14226